

Teil Nr. Part No.	Bezeichnung Description	Material			
		K18 2466 T	K18 2477 T	K18 2493 T	K18 2494 T
1	Gehäuse Body	EN-GJS-400-18-LT Sphäroguss GGG40.3 Ductile iron GGG40.3	EN-GJS-400-18-LT Sphäroguss GGG40.3 Ductile iron GGG40.3	EN-GJS-400-18-LT Sphäroguss GGG40.3 Ductile iron GGG40.3	EN-GJS-400-18-LT Sphäroguss GGG40.3 Ductile iron GGG40.3
2*	Sitzring Seat	PTFE	PTFE	PTFE	PTFE
3	Klappenscheibe / Welle Disc / stem	1.4408/1.4571	PTFE- beschichtet/1.4462 PTFE-coated/1.4462	Alloy C-22 (2.4602)	Titan Ti G2 (3.7035)
4*	Elastomer	EPDM	EPDM	EPDM	EPDM
5	Druckstück Thrust pad	1.4305	1.4305	1.4305	1.4305
6*	Lagerbuchse mit O-Ring Bearing with O-ring	POM / NBR	POM / NBR	POM / NBR	POM / NBR
7	Feder Spring	Federstahl Spring steel	Federstahl Spring steel	Federstahl Spring steel	Federstahl Spring steel
8	Gehäuseschraube Body screw	DIN 912 – A2	DIN 912 – A2	DIN 912 – A2	DIN 912 – A2

* = Verschleißteile / Wearing parts

Wahlweise andere Werkstoffe lieferbar / Other materials available

Änderungen vorbehalten
subject to changes

Baulänge: EN 558-1 Reihe 20 (DIN 3202-K1)
Kopfflansch: ISO 5211

Face to face dimension: EN 558-1 line 20 (DIN 3202-K1)
Mounting plate: ISO 5211

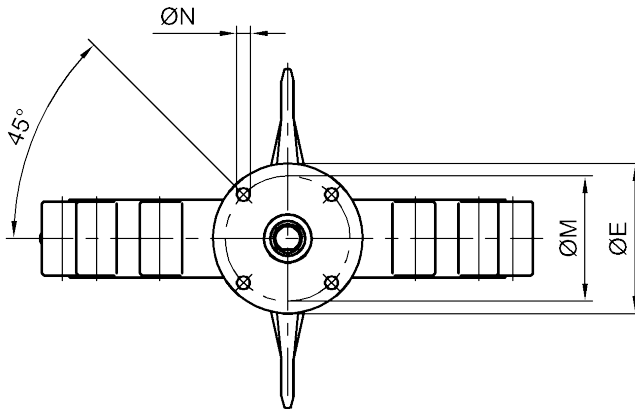
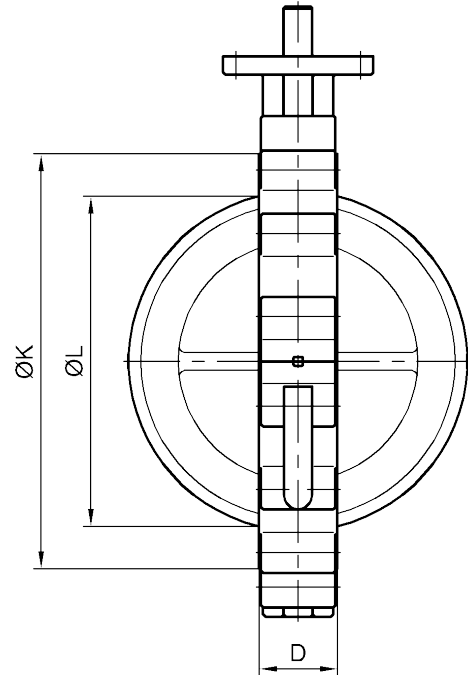
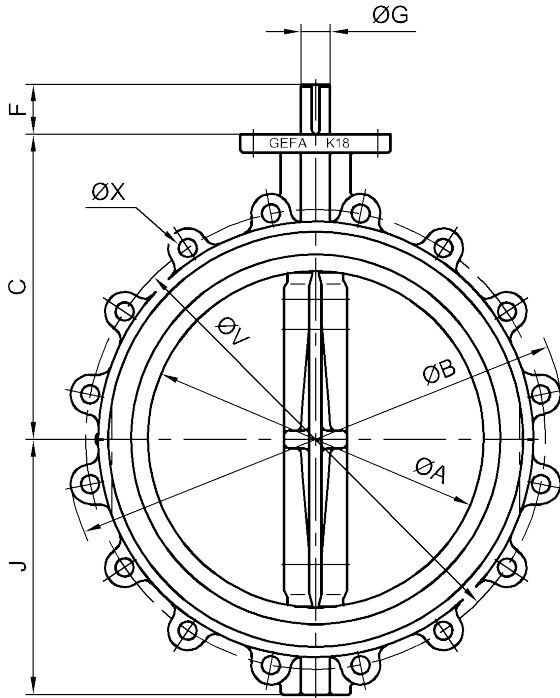

DN	NPS	PN10	
		ØV	ØX
350	14"	460	16 x M20
400	16"	515	16 x M24
500	20"	620	20 x M24

ØK = Sitzring-Außendurchmesser
Seat outside diameter

ØL = kleinster Flanschinnendurchmesser
smallest inside diameter of flange

DN	NPS	ØA	ØB	C	D	ØE	F	ØG	J	ØK	ØL	Passfeder Key DIN 6885	Kopfflansch Mounting plate			kg
													ØM	ØN	ISO 5211	
350	14"	337	500	305	78	150	50	29	255	415	330	8 x 7	125	4 x Ø13	F12	54
400	16"	387	585	330	102	150	60	40	285	469	377	12 x 8	125	4 x Ø13	F12	82
500	20"	490	685	403	127	203	60	50	352	571	475	14 x 9	165	4 x Ø22	F16	193

Änderungen vorbehalten
subject to changes

**Processklappe Serie K16 - K19
 mit Grauguss Getriebe BGPQ
 Butterfly valve series K16 - K19
 with cast iron gear operator BGPQ
 DN 350 - DN 500**

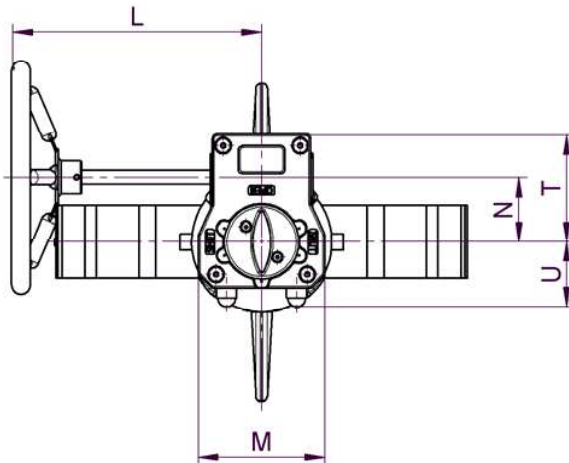
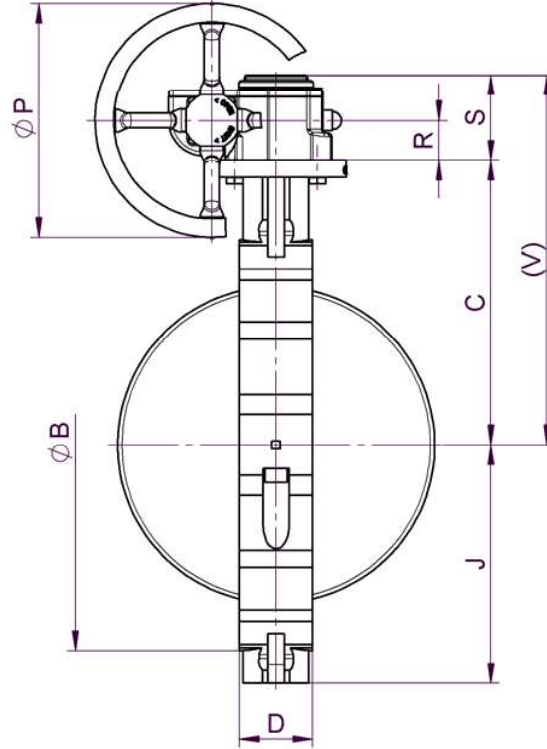
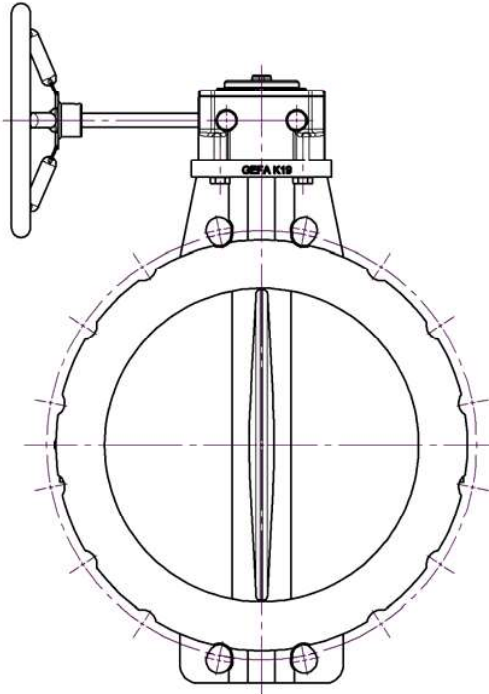

Getriebewerkstoffe / Gear materials

Gehäuse / Body: Grauguss / cast iron
 Welle / Stern: Edelstahl / stainless steel
 Handrad / Handwheel: Stahl / steel

Auf Wunsch ist ein Kettenrad lieferbar
 Gewicht des Getriebes inklusive Handrad.
 Klappenspezifische Daten entnehmen Sie bitte den entsprechenden Datenblättern.

Upon request chain wheel can be supplied.
 Weight of gear operator including handwheel.
 Regarding valve data please refer to relevant data sheets.

DN	NPS	Getriebe Typ Gear type	ØB	C	D	J	L	M	N	ØP	R	S	T	U	V	kg
350 ⁽²⁾	14"	BGPQ800S2925015	440	305	78	255	266	135	69	250	43	91	115	73	473	7,6
350 ⁽²⁾	14"	BGPQ1500S2940020	440	305	78	255	309	156	84	400	45	97	123	83	550	12,5
400	16"	BGPQ1500S4040020	485	330	102	285	309	156	84	400	45	97	123	83	575	12,5
450 ⁽¹⁾	18"	BGPQ2000S4050020	545	370	108	315	379	180	97	500	50	100	144	92	670	16,5
500 ⁽²⁾	20"	BGPQ2000S5050020	600	403	127	352	379	180	97	500	50	100	144	92	703	16,5
500 ⁽²⁾	20"	BGPQ3000S5050020	600	403	127	352	383	250	118	500	49	118	163	115	702	27,0

(1) Nur K17 und K19 / only K17 and K19

(2) Je nach Anwendungsfall / depends on application

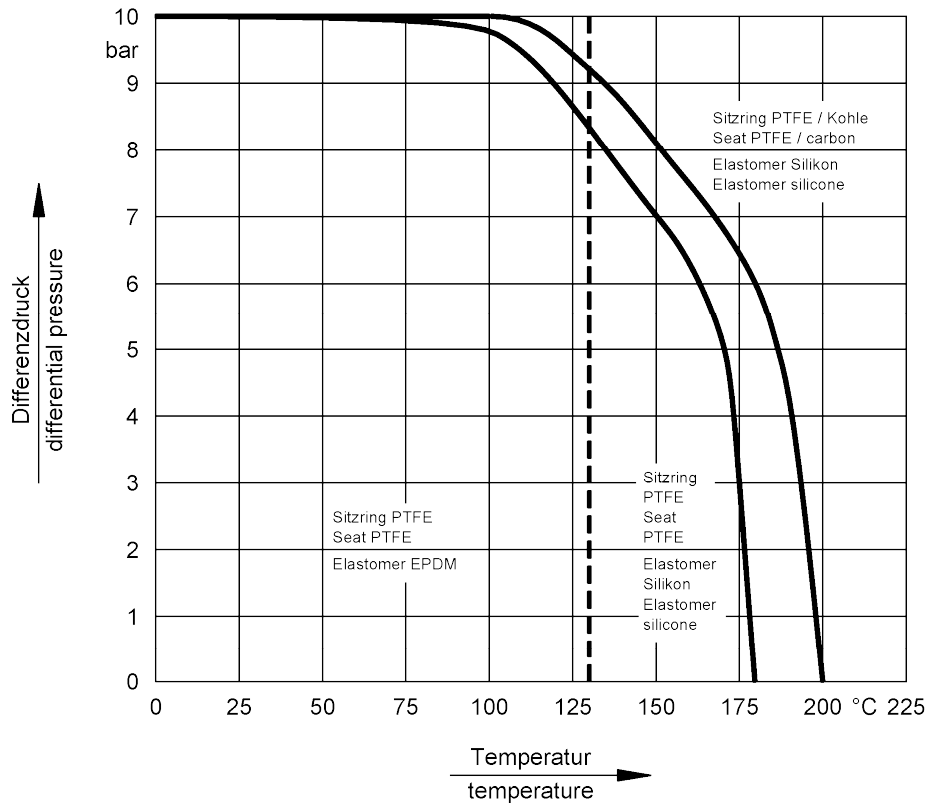

Regelbereich:

20 ° – 60 ° Öffnungswinkel

Armaturen DN 50 bis DN 500:

max. Differenzdruck 10 bar

Vakuumdicht:

DN 50 – bis DN 300: bis 1 mbar(a)

ab DN 350 bis 200mbar(a) für den Temperaturbereich -10°C bis +100°C

Control range:

20° - 60 ° Opening angle

Valves DN 50 up to DN 500:

max. differential pressure 10 bar

Vacuum:

DN 50 – bis DN 300: up to 1 mbar(a)

from DN 350 up to 200mbar(a) for the temperature range -10°C up to +100°C

DN mm	DN inch	Drehmoment Torque (Nm)
40	1½"	30
50	2"	30
65	2½"	36
80	3"	47
100	4"	69
125	5"	112
150	6"	157
200	8"	275
250	10"	412
300	12"	589
350	14"	863
400	16"	1170
500	20"	2139

- Das zu erwartende Betätigungsmoment ergibt sich aus der Summe aller Reibungswiderstände beim Öffnen und Schließen der Armatur.
- Der Einfluß des dynamischen Momentes ist in der Tabelle nicht berücksichtigt.
- Bei der Auslegung von Antrieben ist es nicht erforderlich, einen zusätzlichen Sicherheitsfaktor zu berücksichtigen. In Sonderfällen kann der Klappenscheibendurchmesser reduziert werden, um ein geringeres Drehmoment zu erreichen. Die Klappe ist dann allerdings nur noch bis 3,5 bar dicht.
- The expected torque results from all frictional resistances during opening and closing of the valve.
- The influence of the dynamic moment has not been considered in the table.
- An additional security factor is not necessary for actuator selection. In special cases the diameter of the disc can be reduced to get a lower torque. Then the valve is only tight up to 3,5 bar.

DN	NPS	Klappen Öffnungswinkel / Degree of disc rotation								
		10°	20°	30°	40°	50°	60°	70°	80°	90°
25 / 32	1" / 1 1/4"	0,5	1,8	4,5	7,0	12	18	30	46	53
40	1 1/2"	0,9	4,5	10	17	28	42	67	104	125
50	2"	1,8	7,0	16	26	44	70	115	175	210
65	2 1/2"	2,8	10	23	39	60	95	155	280	340
80	3"	3,5	14	33	57	95	146	240	380	510
100	4"	5,5	25	54	95	155	240	395	620	820
125	5"	8,6	38	86	155	240	385	635	950	1200
150	6"	15	52	120	215	342	547	940	1380	1800
200	8"	21	95	215	376	590	940	1540	2400	3200
250	10"	33	154	342	607	940	1540	2310	4000	5300
300	12"	49	222	504	855	1455	2310	3760	6000	8000
350	14"	65	290	658	1200	1880	2900	4790	8000	9500
400	16"	86	380	855	1540	2395	3850	6325	9500	12000
500	20"	130	610	1370	2480	3930	6160	10260	16000	19000
600	24"	188	855	1970	3420	5470	8550	14100	23000	26000
700	28"	255	1145	2710	4670	7470	11970	19530	30000	36000
800	32"	335	1600	3530	6120	9920	15670	25665	38000	47000
900	36"	430	2220	4440	7770	12820	19660	32500	54000	66000
1000	40"	575	2570	5990	10260	16700	26500	43600	64000	78000

K_v = Durchflussmenge in m³/h bei einem Druckverlust von 1 bar für Wasser ($\rho=1000 \text{ kg/m}^3$)
 K_v = Water flow ($\rho=1000 \text{ kg/m}^3$) in m³/h passing through the valve at a pressure drop of 1 bar
 C_v = Durchflussmenge in US gal/min bei einem Druckverlust von 1 psi für Wasser ($\rho=1000 \text{ kg/m}^3$)
 C_v = Water flow ($\rho=1000 \text{ kg/m}^3$) in US gal/min passing through the valve at a pressure drop of 1 psi
 $C_v = K_v \times 1,16$

Formeln für die Berechnung des K_v -Wertes / Basic formula for calculation of K_v -value

Differenzdruck pressure drop	Flüssigkeit liquid	Gas gas	Dampf steam
$p_2 > \frac{p_1}{2} / \Delta p < \frac{p_1}{2}$	$K_v = Q \cdot \sqrt{\frac{\rho}{1000 \cdot \Delta p}}$	$K_v = \frac{Q_N}{514} \cdot \sqrt{\frac{\rho_N \cdot (t_1 + 273^\circ)}{\Delta p \cdot p_2}}$	$K_v = \frac{G}{316} \cdot \sqrt{\frac{v_2}{\Delta p}}$
$p_2 < \frac{p_1}{2} / \Delta p > \frac{p_1}{2}$	$K_v = Q \cdot \sqrt{\frac{\rho}{1000 \cdot \Delta p}}$	$K_v = \frac{2 \cdot Q_N}{514 \cdot p_1} \cdot \sqrt{\rho_N \cdot (t_1 + 273^\circ)}$	$K_v = \frac{G}{316} \cdot \sqrt{\frac{2 \cdot v}{p_1}}$

Q (m ³ /h)	Durchflussmenge im Betriebszustand	Flow during operation
Q _N (m ³ /h)	Durchflussmenge bei 0 °C, 1013,3 mbar	Flow at 0 °C, 1013,3 mbar
G (kg/h)	Massenstrom	Mass flow
p ₁ (bar)	abs. Vordruck	abs. inlet pressure
p ₂ (bar)	abs. Nachdruck	abs. outlet pressure
Δp (bar)	Differenzdruck (p ₁ -p ₂)	Pressure drop (p ₁ -p ₂)
ρ (kg/m ³)	Dichte im Betriebszustand	Specific gravity of fluid during operation
ρ _N (kg/m ³)	Dichte bei 0 °C, 1013,3 mbar	Specific gravity of fluid at 0 °C, 1013,3 mbar
v ₂ (m ³ /kg)	spezifisches Volumen bei p ₂	Specific volume at p ₂
v (m ³ /kg)	spezifisches Volumen bei p ₁ /2 und t ₁	Specific volume at p ₁ /2 and t ₁
t ₁ (°C)	Betriebstemperatur	Working temperature