

Dual-Plate Check Valves

**BB 1**

**BB 2**

**BB 1 ASME**

**BB 2 ASME**

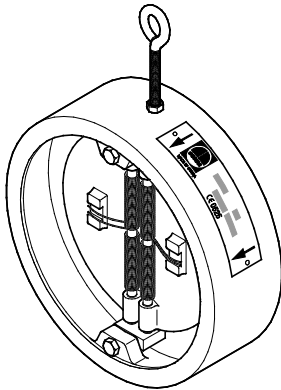
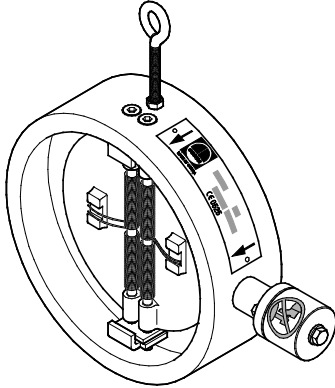

# Contents

<b>Foreword</b> .....	<b>3</b>
Availability .....	3
Formatting features in the document .....	3
<b>Safety</b> .....	<b>3</b>
Use for the intended purpose .....	3
Basic safety notes .....	4
Typographic features of warning notes .....	5
Formatting features for warnings of property damage .....	5
<b>Description</b> .....	<b>5</b>
Scope of supply and equipment specification .....	5
Application of European Directives .....	10
Task and function .....	10
End connections .....	11
<b>Storing and transporting the equipment</b> .....	<b>11</b>
Storing the equipment .....	11
Transporting the equipment .....	12
<b>Mounting and connecting the equipment</b> .....	<b>12</b>
Preparing installation .....	12
Mounting the equipment .....	12
<b>Operation</b> .....	<b>16</b>
<b>After operation</b> .....	<b>16</b>
Removing external dirt deposits .....	16
Maintaining the equipment .....	16
Servicing the equipment and installing spare parts .....	17
<b>Troubleshooting</b> .....	<b>29</b>
<b>Putting the equipment out of operation</b> .....	<b>30</b>
Removing harmful substances .....	30
Removing the equipment .....	30
Re-using equipment after storage .....	31
Disposing of the equipment .....	31
<b>Technical data</b> .....	<b>34</b>
Dimensions and weights .....	34
Pressure & temperature ratings .....	45
<b>Manufacturer's declaration</b> .....	<b>49</b>

## Foreword

This installation & operating manual will help you use the following types of equipment safely and efficiently for their intended purpose.

- ▶ Dual-plate check valve BB 1
- ▶ Dual-plate check valve BB 2
- ▶ Dual-plate check valve BB 1 ASME
- ▶ Dual-plate check valve BB 2 ASME

These types will be called equipment in this document.

This installation & operating manual is intended for anyone commissioning, using, operating, servicing, cleaning or disposing of this equipment and, in particular, for professional after-sales service technicians, qualified personnel and authorised and trained staff.

All of these persons must read and understand the content of this installation & operating manual.

Following the instructions given in this installation & operating manual helps avoiding danger and increases the reliability and service life of the equipment. Please note that in addition to the instructions given in this installation & operating manual you must also observe all locally applicable rules and regulations concerning the prevention of accidents as well as approved safety guidelines for good professional practice.

## Availability

Keep this installation & operating manual together with the plant documentation for future reference. Make sure that this installation & operating manual is available to the operator.

The installation & operating manual is part of the equipment. Please hand over this installation & operating manual when selling the equipment or passing it on.

## Formatting features in the document

Certain text elements of this installation & operating manual feature a specific typographic design. You can easily distinguish the following text elements:

Standard text

*Cross-reference*

- ▶ Listing
  - ▶ Sub-items in listings
- Steps for action.



Here you will find additional useful information and tips serving to assist you in using the equipment to its fullest potential.

## Safety

### Use for the intended purpose

Swing check valves ensure unidirectional flow in pipes by preventing a backflow of liquids or gases.

The equipment must only be used within the allowable pressure and temperature limits and only if the chemical and corrosive influences on the equipment are taken into account.

Correct use includes compliance with the instructions given in this installation & operating manual, in particular obedience to all safety instructions.

Any other use of the equipment is considered to be improper.

The equipment is also considered to be used improperly if:

- ▶ the equipment is installed in pipes where the fluid is delivered by a piston pump or compressor
- ▶ a damper is used outside the rated pressure/temperature range
- ▶ the equipment is used as end valve in a steam line

The equipment is also used improperly if the materials of the equipment are not suitable for the intended service conditions.

## Basic safety notes

### Risk of severe injuries

- ▶ The equipment is under pressure during operation and may be hot. Before carrying out any work on the equipment make sure that the following requirements are met:
  - ▶ The pipes must be depressurized (0 bar).
  - ▶ The fluid must be completely removed from the pipes and the equipment.
  - ▶ During work on the equipment the installation must be switched off and protected against unauthorised or unintended activation.
  - ▶ The pipes and the equipment must have cooled down to room temperature (approx. 20 °C).
- ▶ If the equipment is used in contaminated areas there is a risk of severe injuries or death caused by harmful substances in or on the equipment. Before working on the equipment make sure that it is completely decontaminated. Always wear the protective clothing prescribed for contaminated areas when working on the equipment.
- ▶ The equipment must only be used with fluids that do not attack the material and the gaskets and sealings of the equipment. Otherwise leaks may occur and hot or toxic fluid could escape.
- ▶ The equipment and its component parts must only be mounted or removed by qualified personnel. A qualified person must be acquainted with and experienced in the following:
  - ▶ Making pipe connections.
  - ▶ Selecting suitable lifting gear and understanding the rules for its safe use.
  - ▶ Working with dangerous (contaminated, hot or pressurized) fluids.
- ▶ If installation or removal work is carried out carelessly the springs may shoot out of the body and injure personnel.

Always wear safety goggles when mounting or removing the springs.

When working on the springs make sure that no uninvolved persons are standing in close vicinity of the equipment.

- ▶ If the admissible temperature and pressure limits are exceeded the equipment may be destroyed and hot or pressurized fluid may escape. Make sure that the equipment is only operated within the admissible service range and limits.

For more information on limits and pressure & temperature ratings see name plate and the section "*Technical Data*".

### Risk of minor injuries

- ▶ Sharp edges on internals present the danger of cuts to hands. Always wear industrial gloves when servicing the equipment.
- ▶ If the support of the equipment during installation is insufficient the equipment might fall down, thereby causing bruises or injuries. Make sure the equipment is safely held in place during installation and cannot fall down. Wear protective safety footwear.

### Information on property damage or malfunctions

- ▶ Malfunctions will occur if the equipment is installed in a wrong position or with the flow pattern in the opposite direction of the fluid flow. This may result in damage to the equipment or the installation. Make sure that the flow pattern indicated on the name plate matches the direction of the fluid flow in the pipe.
- ▶ If the material is unsuitable for the fluid, increased wear may occur and fluid may escape. Make sure that the material is suitable for the fluid used in your installation.
- ▶ The equipment may get damaged by pressure impulses, even if the admissible nominal pressure PN is not exceeded. Make sure that the equipment is not subject to pressure impulses or heavily pulsating flow.
- ▶ If the dampers are subjected to stress the equipment may get damaged. Do not use the dampers to lift the equipment. Do not step on the dampers.

- If the dampers are adjusted incorrectly, malfunctions may occur or the equipment may get damaged. Do not change the factory settings of the dampers.

## Typographic features of warning notes



### DANGER

Notes with the heading DANGER warn against imminent dangerous situations that can lead to death or serious injuries.



### WARNING

Notes with the heading WARNING warn against possibly dangerous situations that could lead to death or serious injuries.



### CAUTION

Notes with the heading CAUTION warn against dangerous situations that could lead to minor or moderate injuries.

## Formatting features for warnings of property damage

### *Attention!*

This information warns of a situation leading to property damage.

## Description

## Scope of supply and equipment specification

### Scope of supply

Our equipment is delivered packed and ready for assembly.

## Equipment series and optional extras

Equipment types BB 1 and BB 2 differ from each other in the way the hinge pins for the discs in the body are attached.

Various types of equipment are available which differ from each other in the following:

- Pressure rating
- Body material
- Nominal size
- Seat
- Type of spring
- Designed and manufactured in accordance with DIN or ASME
- Installation of an optional damper (only with equipment with specially designed body).

The following pressure ratings are available:

Type	PN	CLASS (ASME)
BB 11, BB 21	6	–
BB 12, BB 22	10	
BB 14, BB 24	16	125
BB 15, BB 25	25	150
BB 16, BB 26	40	300
BB 17	63	–
BB 18	100	600
BB 19	160	900

The body is available in the following materials:

Code letter	Material
G	Grey cast iron
GS	Grey cast iron with hard rubber coating
GV	Grey cast iron with Vestosint coating
C	Steel
A	Stainless steel

The equipment is available in sizes DN 50 up to DN 1000.

The equipment can feature a seat made from:

- ▶ Metal-to-metal
- ▶ EPDM
- ▶ FPM (FKM)
- ▶ NBR
- ▶ PTFE

The following springs are available.

<b>Code number/letter</b>	<b>Application</b>
7 WA	Spring for 7 mbar opening pressure, for horizontal installation
7 WAI	Inconel spring for 7 mbar opening pressure, for horizontal installation and temperatures > 300 °C
2 WA	Spring for 2 mbar opening pressure, for horizontal installation
5 VO	Spring for 5 mbar opening pressure, for vertical installation with downward flow

For more information on the opening pressures of the spring see the data sheet.

The type designation is a sequence of alphanumeric characters that specifies the type of equipment. If the letters "DPF" are indicated in the type designation, it denotes the installation of a damper.

### **Typical examples of type designations**

- ▶ "BB 12 A 50 EPDM 5 VO"  
BB 1 with PN 10, body made from stainless steel, nominal size 50, seat made from EPDM, with springs for downward flow
- ▶ "BB 26 C 150 FPM 7 WA"  
BB 2 with PN 40, body made from carbon steel, nominal size 150, seat made from FPM, with springs for horizontal flow

## Equipment specification

### Equipment BB 1

The hinge pins of the plates in equipment type BB 1 are attached to the body.

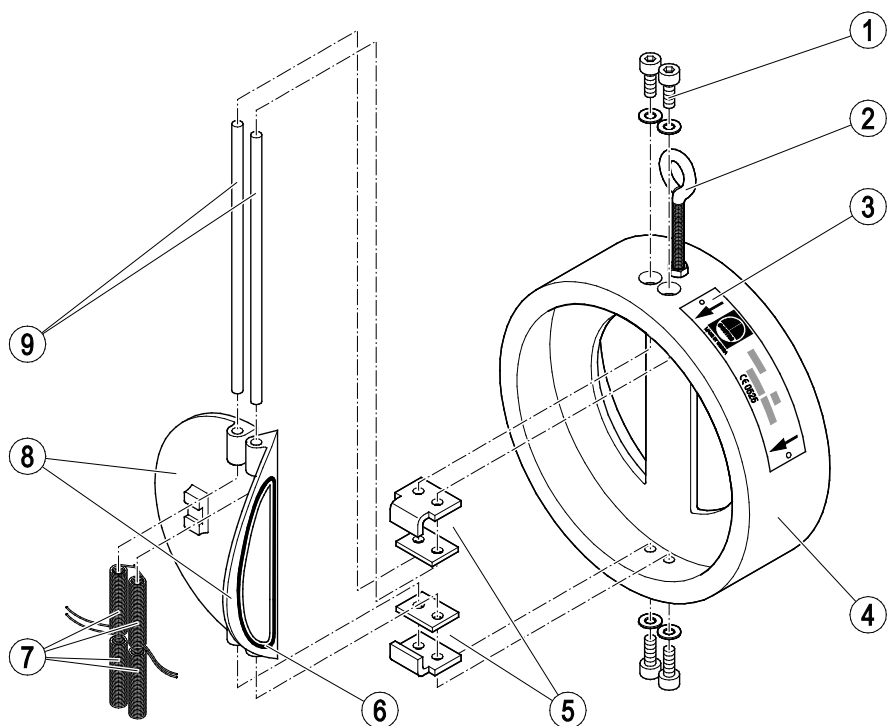

No.	Designation
1	Seal screw with gasket <sup>1</sup>
2	Eye bolt
3	Name plate with flow direction arrow
4	Body
5	Angle bracket or fixing plate for plates <sup>2</sup>

No.	Designation
6	Seal <sup>3</sup>
7	2 pairs of springs
8	Plates
9	Hinge pins

- 2 seal screws on top and 2 on bottom of the body. Smaller equipment features only 2 seal screws on top of the body.
- Depending on the type of equipment angle brackets or fixing plates are used. The following drawings show equipment with angle brackets.
- Some types of equipment have metal-to-metal seats.

## Equipment BB 2

The hinge pins of the plates in equipment type BB 2 are fixed to plate supports attached to the body.

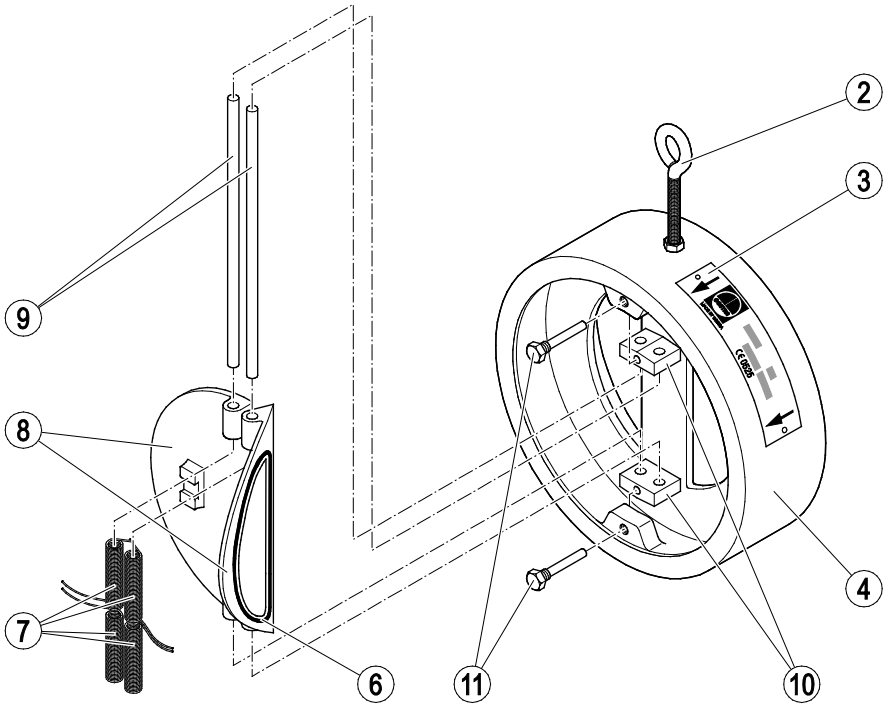

No.	Designation
2	Eye bolt
3	Name plate with flow direction arrow
4	Body
6	Seal <sup>1</sup>
7	2 pairs of springs

No.	Designation
8	Plates
9	Hinge pins
10	Plate support for plates with threaded bolt
11	Threaded bolt

1 Some types of equipment have metal-to-metal seats.



## Equipment with damper

Equipment with optional damper and a corresponding bore in the equipment is available.

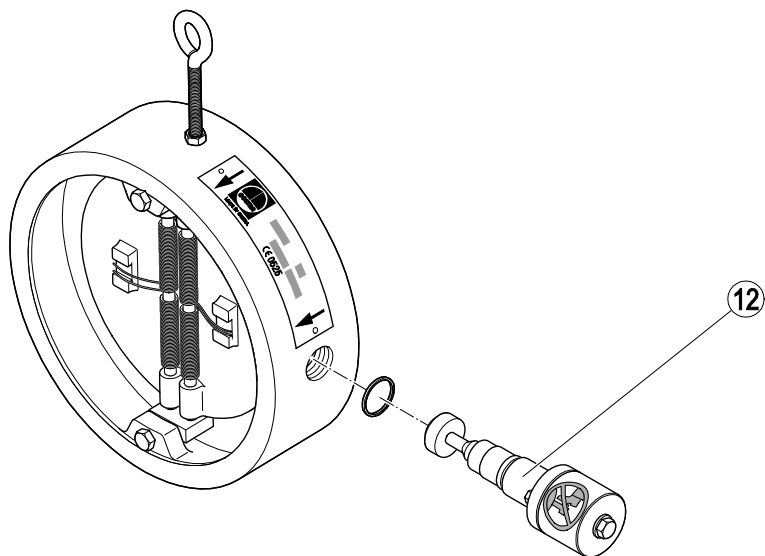

No.	Designation
12	Damper with gasket



For fitting the damper the body of the equipment must be provided with a bore. The standard body does not have such a bore and can therefore not be equipped with a damper.

## Name plate

The indications on the name plates vary according to the equipment type.

The name plate may specify the following:

- ▶ Manufacturer
- ▶ Type designation
- ▶ Design
- ▶ Nominal size
- ▶ Pressure rating
- ▶ Direction of flow
- ▶ CE marking
- ▶ Manufacturing date (quarter/year)
- ▶ Serial number
- ▶ Maximum operating pressure at the associated operating temperature
- ▶ Minimum operating pressure at the associated operating temperature
- ▶ Material specification of plates and seat



Small equipment has the technical specification embossed on its body.

## Application of European Directives

### Pressure Equipment Directive

The equipment conforms to this directive (see "Manufacturer's Declaration" section) and can be used for the following media:

BB G, BB GS and BB GV:

- ▶ Fluids of group 2

BB A and BB C:

- ▶ Fluids of group 1
- ▶ Fluids of group 2

## ATEX Directive

The equipment does not have its own potential ignition source and is not subject to this directive (see "Manufacturer's Declaration" section).

When installed, static electricity may arise between the equipment and the connected system.

When used in potentially explosive atmospheres, the plant manufacturer or plant operator is responsible for discharging or preventing possible static charge.

If it is possible for medium to escape, e.g. through actuating mechanisms or leaks in threaded joints, the plant manufacturer or plant operator must take this into consideration when dividing the area into zones.

## Task and function

### Purpose

The equipment prevents the backflow of liquids or gases in pipes.

The equipment can be installed in horizontal and vertical pipes.

If the equipment is mounted in a vertical pipe the flow must normally be from bottom to top.

If springs of type 5 VO are used, the equipment can also be installed in vertical pipes with downward flow. This kind of installation (vertically downward flow) is only possible with equipment up to DN 500.

### Function

Two valve plates open and close the pipe as a function of the flow direction of the fluid.

Each one of the two plates is closed by two springs guided by the hinge pin. The opening pressure depends on the type of spring used.

## Dampers

Optional dampers can be used to influence the closing characteristics. A dampening medium slows down the plate movement during the last 15° of the closing path. As a result the plates close more slowly and, as a consequence, problems caused by pressure surges in the pipe are prevented.

The optional dampers can be used with temperatures up to 110 °C.

Note that the dampers must not be used in pressure booster installations if the pressure at the suction side exceeds 0.5 bar.

In these installations pressure compensation between the suction and the pressure side of the equipment may occur. The equipment may not close properly any longer.

## End connections

The equipment can be mounted between the following flanges to EN 1092-1:

- ▶ Form B1 and Form B2
- ▶ Form C
- ▶ Form F
- ▶ Form G

Equipment types BB 1 ASME and BB 2 ASME may be mounted between flanges to ASME B16.1, B16.5 or B16.47.

## Storing and transporting the equipment

### **Attention!**

Equipment can be damaged if stored or transported improperly.

- ▶ Close all openings with the sealing plugs or covers supplied with the equipment or use similar sealing covers.
- ▶ Protect the equipment against moisture and corrosive atmospheres.
- ▶ Please contact the manufacturer if the specified transport and/or storage requirements cannot be met.

## Storing the equipment

- ▶ Please observe the following items when storing the equipment:
  - ▶ Do not store the equipment for more than 12 months.
  - ▶ Protect the sealing surfaces and contact areas against mechanical damage.
  - ▶ Protect the equipment and all components against hard shocks and impacts.
  - ▶ Store the equipment only in closed rooms that meet the following environmental conditions:
    - ▶ Air humidity below 50 %, not condensing
    - ▶ Indoor air: clean, salt-free and non-corrosive
    - ▶ Temperature 5–40 °C.
- ▶ Make sure that all these requirements are always met when storing the equipment.
- ▶ Please contact the manufacturer if you cannot comply with the recommended storage conditions.

## Transporting the equipment

- Meet the requirements for storage also when transporting the equipment.
- For short distances (only a few metres) you can transport the equipment unpacked.
- When transporting the equipment over larger distances use the original packaging.
- If you do not have the original packaging use a box that protects the equipment adequately against corrosion and physical damage.



For a short period of time the equipment may be transported even if the temperature is below 0 °C, provided that the equipment is completely empty and dry.

## Mounting and connecting the equipment

### Preparing installation

- Take the equipment out of the transport packaging.
- Check the equipment for transport damage.
- Contact the manufacturer if you detect any kind of shipping damage.



### DANGER

Personnel working on pipes are exposed to safety risks and may suffer severe injuries, poisoning or even loss of life.

- Make sure that no hot or hazardous fluid is in the equipment or the pipes.
- Make sure that the pipes upstream and downstream of the equipment are depressurised.
- Make sure that the installation is switched off and protected against unauthorised or unintended activation.
- Make sure that the equipment and the pipes have cooled down to room temperatures.
- Wear protective clothing that is suitable for the fluid and, if necessary, wear protective gear.

For more information on suitable safety clothing and safety gear refer to the safety data sheet of the fluid in question.

- Drain pipes until they are empty.
- Switch the installation off and protect it against unauthorised or unintended re-activation.

## Mounting the equipment

### Attention!

Equipment will be damaged if the end connections are undersized.

- Make sure that the connections are strong and rigid enough to support the weight of the equipment and to withstand the forces that occur during operation.

---

### **Attention!**

Excessive loads may damage the closing dampers.

- Use the eye bolt for fixing lifting gear.
- Do not stress the closing dampers.

- 
- Make sure that the pipe system of the plant is clean.
  - Make sure that the equipment is free from foreign matter.
  - Ensure that all joint faces and sealing surfaces are clean.
  - Make sure that the equipment is safely mounted and that all connections are made correctly.
  - If the fluid temperature exceeds 300 °C a spring made from Inconel must be fitted.
  - Make sure that the equipment is only operated within the admissible service range and limits.

The equipment can be installed in horizontal or vertical pipes. There is no significant difference in the installation work.

The equipment can also be installed in pipes with bends. In this case you have to install the equipment downstream of the pipe bend.

A straight distance of at least five times the nominal pipe diameter for stabilizing the flow pattern must be left upstream of the equipment.

---

### **Attention!**

Malfunctions may occur if the stabilizing distance is not sufficient.

- Make sure that the distance between the pump and the equipment is enough to provide a stabilized flow pattern.
- 

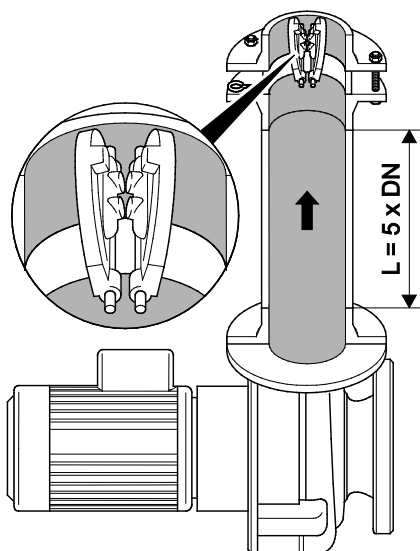

---

### **Installing the equipment with vertical direction of flow**

#### **DANGER**

Incorrectly connected equipment can cause fatal accidents or severe injuries.

- Make sure that only qualified skilled personnel connect the equipment to pipes.
- Make sure that the flow arrow on the equipment body matches the direction of flow in the pipe.

---

Specialist personnel must be highly qualified and fully experienced in making pipe connections for the respective type of end connection.

## Attention!

If the installation position is incorrect malfunctions may occur and/or the equipment or the installation may get damaged.

- Make sure that the equipment is installed in the correct position.
- Mount the equipment downstream of a pipe bend.
- When installing the equipment make sure that the eye bolt points towards the inside of the pipe bend.

The correct position of installation is indicated by the position of the eye bolt and the flow arrow on the nameplate.

If the equipment is installed in a vertical pipe the flow arrow must point upwards.

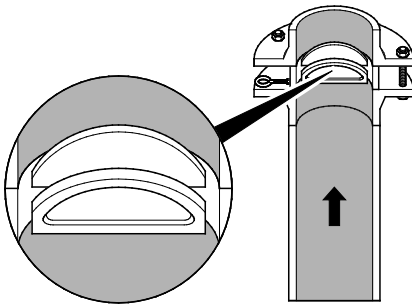

- i** The equipment can also be installed in vertical pipes with downward flow.
  - For this purpose make sure that the equipment is fitted with springs of type 5 VO.

If the equipment is installed downstream of a pipe bend the eye bolt must point towards the inside of the pipe bend.

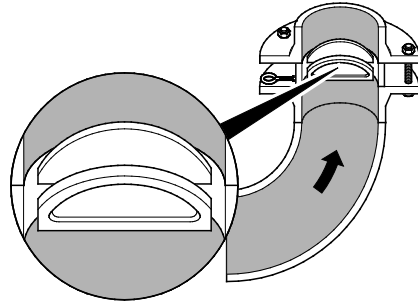

- Put a commercially available gasket that is suitable for the pipe onto the lower flange.
- Put the equipment onto the gasket.
- Put a commercially available gasket that is suitable for the pipe onto the equipment.
- Put the upper flange onto it.
- Insert all bolts through the holes in the flange.
- Make sure that all component parts are in central alignment with each other.
- Screw the nuts onto the bolts.

**i** To obtain the desired position of installation you can turn the equipment with the eye bolt.

- Turn the equipment into the desired installation position.
- Tighten the nuts on the bolts evenly.

**i** The torque required for tightening the nuts depends on the pipe.

## Installing the equipment with horizontal direction of flow



### DANGER

Incorrectly connected equipment can cause fatal accidents or severe injuries.

- Make sure that only qualified skilled personnel connect the equipment to pipes.
- Make sure that the flow arrow on the equipment body matches the direction of flow in the pipe.

Specialist personnel must be highly qualified and fully experienced in making pipe connections for the respective type of end connection.

### Attention!

If the installation position is incorrect malfunctions may occur and/or the equipment or the installation may get damaged.

- Make sure that the equipment is installed in the correct position.
- When installing the equipment make sure that the eye bolt points upwards.

The correct position of installation is indicated by the position of the eye bolt and the flow arrow on the nameplate.

If the equipment is installed in a horizontal pipe the eye bolts must point upwards.

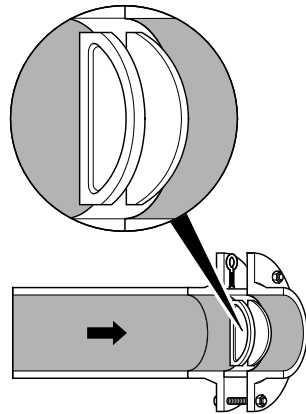

If the equipment is installed in horizontal position you can use the lower bolts as support for the equipment.

- First insert the lower bolts through the holes in the flange.
- Then insert the two lower bolts into the second flange.
- Put two commercially available gaskets that are suitable for the pipe between the flanges.
- Put the equipment between the gaskets.
- Make sure that all component parts are in central alignment with each other.
- Insert the upper bolts.
- Align the equipment so that the eye bolt points upwards.
- Tighten the nuts on the bolts evenly.



The torque required for tightening the nuts depends on the pipe.

## Operation

Do not work on the equipment while it is operating.

and carefully wipe the equipment with a clean, lint-free cloth.

## After operation



### DANGER

If fluid escapes personnel may suffer severe injuries, poisoning or even loss of life.

- After working on the equipment make sure that all connections and valves are tight.
- Make sure that the gaskets of the body are leakproof.



### DANGER

If the equipment is used in contaminated areas there is a risk of severe injuries or death caused by harmful substances in or on the equipment.

- Only qualified personnel are allowed to perform work on contaminated equipment.
- Always wear the protective clothing prescribed for contaminated areas when working on the equipment.
- Make sure that the equipment is completely decontaminated before carrying out any service work.
- Follow the pertinent instructions for handling the hazardous substances in question.

## Maintaining the equipment

The equipment is maintenance-free.

## Removing external dirt deposits

- To remove dirt deposits rinse the equipment with fresh water and wipe it with a clean, lint-free cloth.
- To remove any persistent residues use a cleaning agent that is suitable for the material



## Servicing the equipment and installing spare parts

You may exchange the following component parts in case of wear or damage:

- ▶ Gasket (6)  
For small quantities please contact your local dealer.
- ▶ Spring (7)  
complete with tension plate

These spare parts are identical for all types of BB.  
The mounting and removing procedures for BB 1 and BB 2 are different.

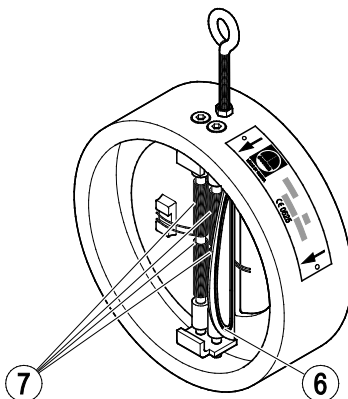

### Stock code numbers of spring (7)

DN	Stock code #			
	2 WA	7 WA	7 WAI	5 VO
50	349345	349344	–	349346
65	349348	349347	–	349349
80	349391	349390	–	349392
100	348200	348190	348220	348198
125	348201	348191	348221	348199
150	348202	348192	348222	348209
200	348203	348193	348223	348211
250	348204	348194	348224	348213
300	348205	348195	348225	348215
350	348206	348196	348226	348216
400	348207	348197	348227	348217
450	348586	348580	348592	348598
500	348587	348581	348593	348600
600	348588	348582	348594	–
700	348589	348583	348595	–
800	348591	348585	348597	–

### Stock code numbers of gasket (6)

DN	Stock code #			
	O ring EPDM	O ring FPM	O ring NBR	O ring PTFE
50	340463	340465	347866	–
65	0340065	0340067	340066	–
80	037839	039082	349037	–
100	037847	038982	038543	–
125	346777	346778	346779	–
150	342598	342711	342931	342978
200	342710	342713	344372	343721
250	342522	342523	344484	344491
300	182574	038718	340825	344592
350	342565	342569	038705	175131
400	342584	342585	344714	344715
450	038948	180962	037020	–
500	036002	036007	182719	343876
600	036003	180210	122490	–
700	036987	343603	182114	–
800	039663	181939	–	–

## Removing the equipment

To exchange the spring or the gasket you have to remove the equipment.



You may not be able to move heavy component parts in large equipment.

➤ In this case use suitable lifting / support equipment and tools.

The load carrying capacity of lifting gear and tools must at least be rated for the total weight of the equipment.

➤ For more information on the weight of the individual component parts please contact the manufacturer.



### DANGER

Risk of bruises if the equipment or component parts fall down.

- Use suitable lifting gear when moving or lifting the equipment and/or component parts.
- Make sure that the equipment cannot topple over.
- Make sure that nobody is standing below the lifted equipment.

### Attention!

Excessive loads may damage the closing dampers.

- Use the eye bolt for fixing lifting gear.
- Do not stress the closing dampers.

- Undo the nuts on the bolts.
- Pull the equipment out of the flanges.
- Remove the gaskets from the flanges.

## Removing dampers of BB 1

To mount and remove the spring you need the following tools:

- Socket spanner A. F. 13, 17, 19, 22, 24 DIN 3124
- Hexagon socket spanner A. F. 5, 6, 10, 12, 17, 22, 24 ISO 2936
- Torque spanner DIN ISO 6789
- Flat pliers DIN ISO 5745
- Stable cover for springs
- Hinged face spanner A. F. 2 -8 (for equipment with body lining made from Vestosint/hard rubber)



The number of sealing screws depends on the equipment type.

Small equipment features two sealing screws next to the eye bolt.

Larger equipment has two additional sealing screws on the other end of the body.

- Slacken the sealing screws (1) in the body.
- Take the sealing screws and the respective gaskets out of the equipment.

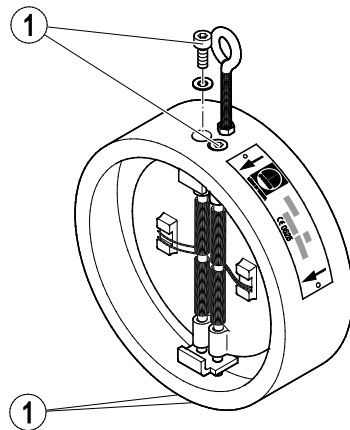



## DANGER

Risk of bruises if the equipment or component parts fall down.

- Use suitable lifting gear when moving or lifting the equipment and/or component parts.
- Make sure that the equipment cannot topple over.
- Make sure that nobody is standing below the lifted equipment.

- Put the equipment with the springs on top onto a bearing surface of sufficient integrity and stability.



## WARNING

The springs are preloaded and their tension can cause injuries.

- Always wear safety goggles when replacing the springs.
- Mount or remove one spring after the other.
- Make sure that no uninvolved persons are standing in close vicinity of the equipment.

- Cover the springs with a stable cover (13) (1.).
- Use the flat pliers to pull the two hinge pins (9) out of the body (2.).

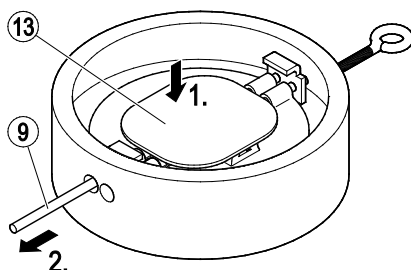

- Remove the cover.

- Take the four springs (7) out of the body (1.).
- Spread the plates slightly apart (2.).

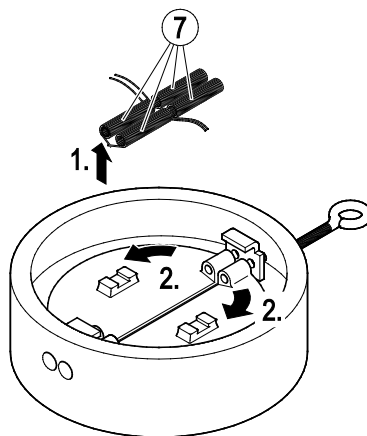

Depending on the type of equipment angle brackets or fixing plates are incorporated. The removal procedure is the same for both items.



## DANGER

Risk of bruises if the equipment or component parts fall down.

- Use suitable lifting gear when moving or lifting the equipment and/or component parts.
- Make sure that the equipment cannot topple over.
- Make sure that nobody is standing below the lifted equipment.

- Lift the two plates (8) out of the body (1.).
- Lift the plates or angle brackets (5) out of the body (2.).

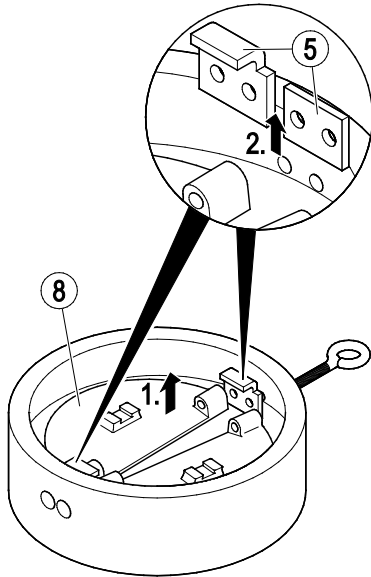

## Removing dampers of BB 2

To mount and remove the spring you need the following tools:

- ◆ Socket spanner A. F. 13, 17, 19 DIN 3124
- ◆ Torque spanner DIN ISO 6789
- ◆ Flat pliers DIN ISO 5745
- ◆ Stable cover for springs
- ◆ Hinged face spanner A. F. 2 -8 (for equipment with body lining made from Vestosint/hard rubber)

- Slacken the two threaded bolts (11) in the body (1.).
- Turn the plates and the springs as shown in the illustration (2.).

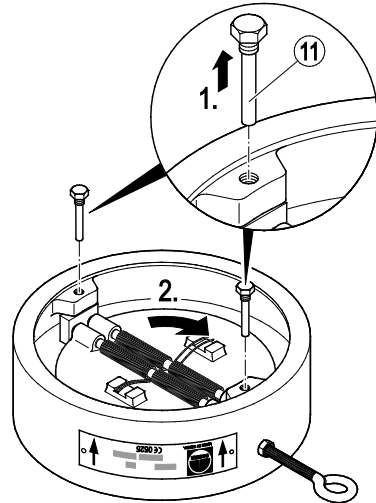



## WARNING

The springs are preloaded and their tension can cause injuries.

- Always wear safety goggles when replacing the springs.
- Mount or remove one spring after the other.
- Make sure that no uninvolved persons are standing in close vicinity of the equipment.



For larger equipment use lifting gear to lift the plates out of the body.

- Insert two eye bolts in the bores for the threaded bolts (11) in the plate supports.
- Attach lifting gear of sufficient load bearing capacity to the eye bolts.



## DANGER

Risk of bruises if the equipment or component parts fall down.

- Use suitable lifting gear when moving or lifting the equipment and/or component parts.
  - Make sure that the equipment cannot topple over.
  - Make sure that nobody is standing below the lifted equipment.
- 
- Lift off the plates at the plate supports.
  - Take the plates together with the springs and plate supports out of the body.

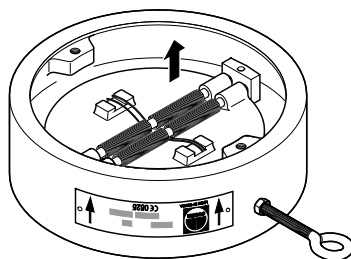

- Put the plates onto a bearing surface of sufficient integrity and stability.
- Put a flat and stable cover (13) onto the springs (1.).
- Pull the plate supports (10) off the hinge pins as shown (2.).

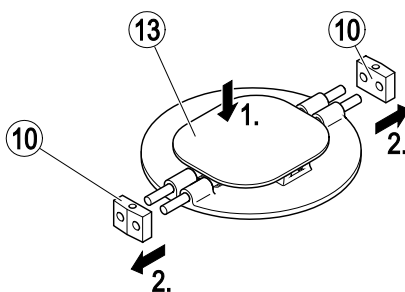



## WARNING

The springs are preloaded and their tension can cause injuries.

- Always wear safety goggles when replacing the springs.
- Mount or remove one spring after the other.
- Make sure that no uninvolved persons are standing in close vicinity of the equipment.

- Remove the cover.
- Carefully pull the two plates apart until the springs are decompressed (1.).
- Pull the two hinge pins (9) out of the springs (7) (2.).

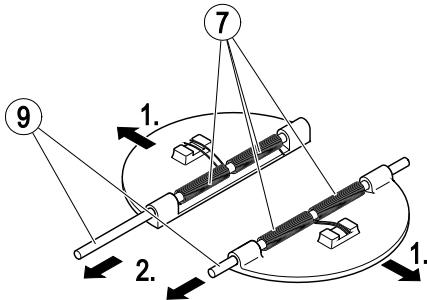

## Exchanging the gasket



The limiting conditions for the gaskets depend on the temperature and the fluid used.

Some types of equipment have metal-to-metal seats. Their seals cannot be changed.

The following drawing shows the equipment type BB 1. The gasket in the equipment of type BB 2 can be exchanged in the same way.

- Use a punch to detach the gasket (6) from the plate.

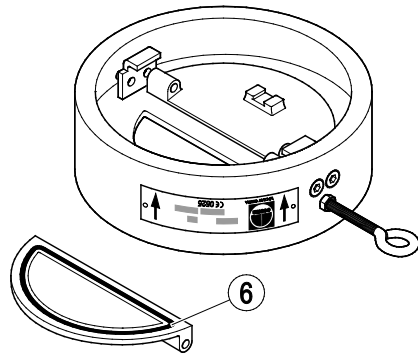

- Select the new type of gasket according to the desired application of the equipment.
- Insert a new gasket in each plate.
- Make sure that the gaskets are properly inserted.

## Mounting dampers of BB 1

- Insert an angle bracket or plate (5) into the body.



### **DANGER**

Risk of bruises if the equipment or component parts fall down.

- Use suitable lifting gear when moving or lifting the equipment and/or component parts.
  - Make sure that the equipment cannot topple over.
  - Make sure that nobody is standing below the lifted equipment.
- 
- Put the two plates (8) as shown into the body (3.).
  - Insert the second angle bracket or the second plate (5) into the body.

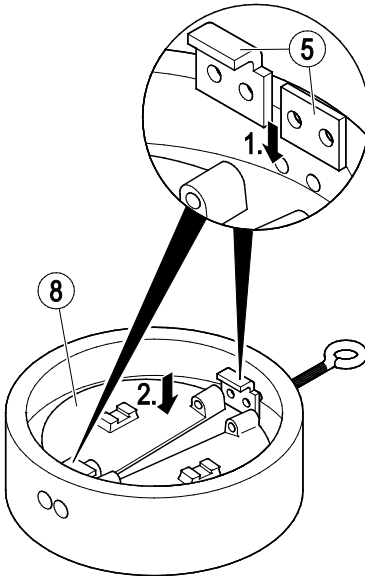

- Align all parts until the bores are in perfect alignment.
- Push the two hinge pins through the bores in the body and in the plates or angle brackets.

- Make sure that the hinge pins are securely located in the bores.



### **WARNING**

The springs are preloaded and their tension can cause injuries.

- Always wear safety goggles when replacing the springs.
  - Mount or remove one spring after the other.
  - Make sure that no uninvolved persons are standing in close vicinity of the equipment.
- 
- Pull one hinge pin out of the body until you can insert the springs.
  - Put the springs with tension plates (7) onto the plate (1.).
  - Push the hinge pin into the body until it hits the stop (2.).

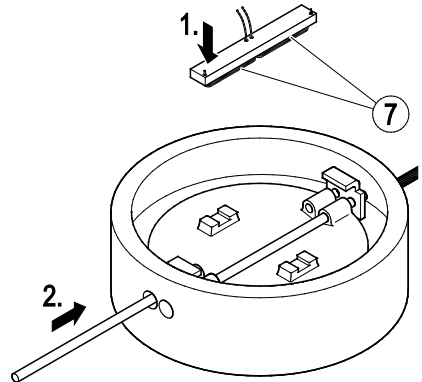

- Pull the second hinge pin (9) out of the body.

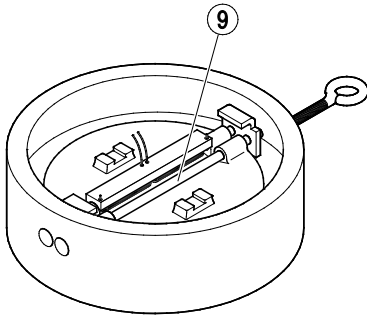

- Put the springs with tension plates as described onto the second plate.

**i** Large equipment is fitted with four sealing screws (1). Small equipment has only two sealing screws. The following drawing shows the equipment with four sealing screws. The two sealing screws on top next to the eye bolt are not shown.

- Screw the sealing screws (1) with gaskets handtight into the bores in the body.

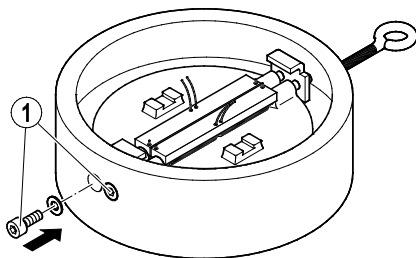

## WARNING

The springs are preloaded and their tension can cause injuries.

- Always wear safety goggles when replacing the springs.
  - Mount or remove one spring after the other.
  - Make sure that no uninvolved persons are standing in close vicinity of the equipment.
- 
- Carefully pull the tension plates (14) off the springs.

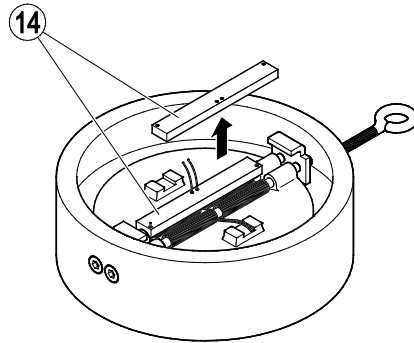

The required torque for tightening the sealing screws (1) depends on the material of the screws and the body as well as the nominal size and body type. For information on the required tightening torques see the following tables.

- Fasten the sealing screws with the specified tightening torque.



**Tightening torque [Nm] for sealing screws made from austenitic steel**

DN	BB 11	BB 12, BB 14 BB 15, BB 16	BB 17, BB 18	BB 19
50	–	5	5	–
65	–	5	5	–
80	–	12	12	–
100	–	13	13	–
125	–	13	27	–
150	–	–	65	65
200	–	–	135	135
250	–	–	135	135
300	–	–	135	320
350	–	–	260	–
400	–	–	320	–
450	310	310	–	–
500	310	310	630	–
600	310	310	630	–
700	1,080	1,080	–	–
800	2,240	2,240	–	–
900	1,940	1,940	–	–
1000	1,940	1,940	–	–

**Tightening torque [Nm] for sealing screws made from bronze**

DN	BB 11	BB 12, BB 14 BB 15, BB 16
450	310	310
500	310	310
600	310	310
700	460	460
800	940	940
900	1,420	1,420
1000	1,420	1,420

**Mounting dampers of BB 2**



**WARNING**

The springs are preloaded and their tension can cause injuries.

- Always wear safety goggles when replacing the springs.
- Mount or remove one spring after the other.
- Make sure that no uninvolved persons are standing in close vicinity of the equipment.

- Put the springs (7) with tension plates (14) as shown onto the plates (8.).

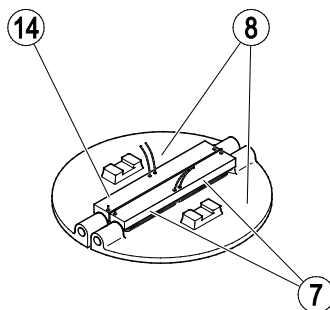

- Push the two hinge pins (9) through the springs (1.).

- Put the two plate supports (10) as shown onto the ends of the hinge pins (2.).

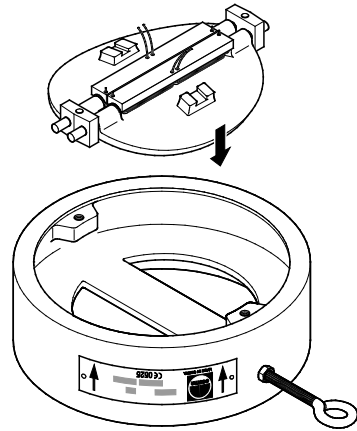
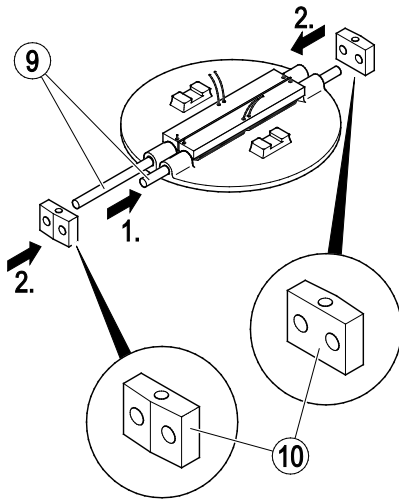

To mount the plates in large equipment use suitable lifting gear. Attach the lifting gear to the plates as follows:

- Insert two eye bolts in the bores for the threaded bolts (11) in the plate supports.
- Attach lifting gear of sufficient load bearing capacity to the eye bolts.



## DANGER

Risk of bruises if the equipment or component parts fall down.

- Use suitable lifting gear when moving or lifting the equipment and/or component parts.
- Make sure that the equipment cannot topple over.
- Make sure that nobody is standing below the lifted equipment.

- Lift off the plates at the plate supports.
- Put the plates as shown into the body.

- Remove the eye bolts and keep them for future use.
- Turn the plates until the bores in the plate supports are underneath the stops (1.).
- Insert the two threaded bolts (11) (2.).

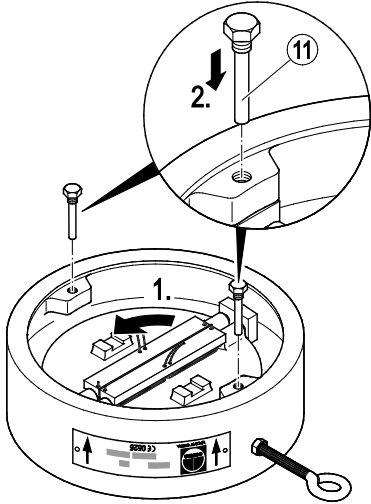

The required torque for tightening the threaded bolts (11) depends on the material of the threaded bolt and the body as well as the nominal size. For information on the required tightening torques see the following table.

- Fasten the threaded bolts with the specified tightening torque.

**Tightening torque [Nm] for threaded bolts in BB 21, BB 22, BB 24, BB 25 and BB 26**

DN	Threaded bolt made from steel		Threaded bolt made from bronze	
	Body without lining	Body with lining	Body without lining	Body with lining
150	15	7.5	17	8
200	15	7.5	17	8
250	26	15	28	17
300	26	15	28	17
350	26	26	28	28
400	70	42	78	47

- Carefully pull the tension plates (14) off the springs.

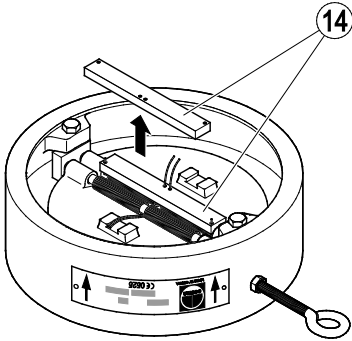

### **Installing the equipment**

- Make sure that the plates can move smoothly.
- Mount the equipment into the pipe as described in section "*Mounting the equipment*" from page 12 onwards.

## Troubleshooting

Problem	Cause	Remedy
Loud noise	The equipment is operating in the unstable range of the volume flow with the swing disk oscillating.	Raise the volume flow by increasing the pump capacity.
		Install the equipment at a different position.
	The distance between the equipment and the pump is too short.	Increase the distance of the equipment so that a stabilized flow is provided.
Equipment leaks	The equipment is damaged.	Check the condition of the equipment. Replace the equipment if it is damaged.
	The spring is damaged or worn.	Check the condition of the springs. Replace any damaged or worn spring.
	A gasket is damaged.	Check the condition of the gaskets. Replace any defective gasket.

## Putting the equipment out of operation

### Removing harmful substances



#### **DANGER**

If the equipment is used in contaminated areas there is a risk of severe injuries or death caused by harmful substances in or on the equipment.

- Only qualified personnel are allowed to perform work on contaminated equipment.
- Always wear the protective clothing prescribed for contaminated areas when working on the equipment.
- Make sure that the equipment is completely decontaminated before carrying out any service work.
- Follow the pertinent instructions for handling the hazardous substances in question.

Qualified personnel must have extensive experience with and a working knowledge of:

- ◆ pertinent rules and regulations concerning handling hazardous substances
- ◆ special regulations for handling the hazardous substances encountered on site
- ◆ using the required personal protective equipment (PPE) and clothing

#### ***Attention!***

Environmental damage may be caused by poisonous fluid residues.

- Before disposing of the equipment make sure that it is clean and free of fluid residues.
  - For the disposal of all materials observe the pertinent legal regulations concerning waste disposal.
- 
- Remove all residues from the equipment.
  - For the disposal of all residues observe the pertinent legal regulations concerning waste disposal.

### Removing the equipment



#### **DANGER**

Personnel working on pipes are exposed to safety risks and may suffer severe injuries, poisoning or even loss of life.

- Make sure that no hot or hazardous fluid is in the equipment or the pipes.
- Make sure that the pipes upstream and downstream of the equipment are depressurised.
- Make sure that the installation is switched off and protected against unauthorised or unintended activation.
- Make sure that the equipment and the pipes have cooled down to room temperatures.
- Wear protective clothing that is suitable for the fluid and, if necessary, wear protective gear.

For more information on suitable safety clothing and safety gear refer to the safety data sheet of the fluid in question.



## CAUTION

Danger of bruising if the equipment falls down.

- When removing the equipment make sure the it is safely held in place and cannot fall down.

---

Suitable measures are for instance:

- ▶ Equipment that is not too heavy may be supported by a second person.
- ▶ For heavy equipment use suitable lifting equipment of sufficient strength.

---

## ***Attention!***

Excessive loads may damage the closing dampers.

- Use the eye bolt for fixing lifting gear.
  - Do not stress the closing dampers.
- 
- Detach the equipment from the pipes.
  - Put the equipment onto a suitable base.
  - Store the equipment as described in section "*Storing the equipment*" on page 11.

## Re-using equipment after storage

Observe the following instructions if you want to remove the equipment and use it again somewhere else:

- ▶ Make sure that the equipment is free of any fluid residues.
- ▶ Make sure that all connections are in good condition and leak-free.
- ▶ Replace the gaskets in the equipment with new ones of the same type.
- ▶ Replace the gaskets at the connections of the equipment with new ones of the same type.
- Use the equipment only for its intended purpose and the service conditions for which it was specified.

---

## Disposing of the equipment

### ***Attention!***

Environmental damage may be caused by poisonous fluid residues.

- Before disposing of the equipment make sure that it is clean and free of fluid residues.
- For the disposal of all materials observe the pertinent legal regulations concerning waste disposal.

---

The equipment is made from the following materials:

**Materials BB 1 and BB 2****Made from carbon steel (BB.. C)**

<b>Component</b>	<b>DN</b>	<b>EN number</b>	<b>ASME</b>
Body	100–125 (4–5'')	1.0460	A105
	from 150 (from 6'') <sup>1</sup>	1.0619	A216WCB
Dual plates		1.0619	A216WCB
Support and hinge pin		1.4571	A316Ti
Springs up to 300 °C		1.4571	A316Ti
Springs from 300 °C		Inconel	Inconel

<sup>1</sup> Special hard-faced body sealing surfaces from DN 150 available on request.

**Made from stainless steel (BB.. A)**

<b>Component</b>	<b>DN</b>	<b>EN number</b>	<b>ASME</b>
Body	50–125 (2'–5'')	1.4404	A182F316L
	from 150 (from 6'')	1.4408	A351CF8M
Dual plates	50–80 (2'–3'')	1.4404	A182F316L
	from 100 (from 4'')	1.4408	A351CF8M
Support and hinge pin		1.4571	A316Ti
Springs up to 300 °C		1.4571	A316Ti
Springs from 300 °C		Inconel	Inconel



### Made from grey cast iron (BB.. G, GS, GV)

Component	EN number	ASME <sup>1</sup>
Body	EN-JL 1040	A126B
Dual plates for standard equipment	EN-JS 1030	A536 60-40-18
Dual plates for equipment with anti-corrosion lining and austenitic internals	1.4408	A351CF8M
Support and hinge pin	1.4571	A316Ti
Springs		
Dual plates for equipment with anti-corrosion lining and internals made from bronze	CC332G	— <sup>2</sup>
Support and hinge pin	CW453K	C51900
Springs	CW452K	C52100

- 1 Equipment made from grey cast iron that complies with ASME specification is not available. The equivalent material specifications are stated for guidance only. Physical and chemical properties of the materials can therefore differ from the materials in accordance with ASME specification. For more details please contact the manufacturer.
- 2 For the EN material there is no ASME equivalent.

The gaskets can be made from the the following materials:

Type	Material
EPDM	Ethylene propylene dien rubber
FPM (FKM)	Fluoro rubber (e. g. Viton)
NBR	Acrylonitrile butadiene rubber (e. g. Perbunan)
PTFE	Polytetrafluoroethylene (e. g. Teflon)

## Technical data

### Dimensions and weights



The weight ratings refer to material type 1.0619 (A216WCB).

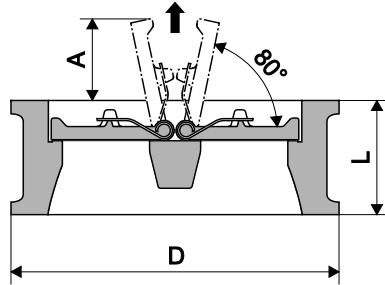

#### BB 11 G, PN 6

DN	Dimensions [mm]			Weight [kg]
	D	L	A	
450	530	152	163	125
500	580	152	181	144
600	681	178	217	223
700	786	229	250	305
800	893	241	290	462
900	993	241	327	571
1000	1,093	300	364	808

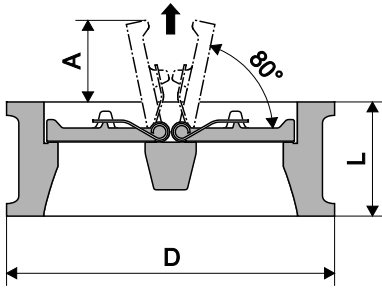

### BB 12, PN 10

DN	Dimensions [mm]			Weight [kg]
	D	L	A	
50 <sup>1</sup>	109	43	8	2.5
65 <sup>1</sup>	129	46	11	4
80 <sup>1</sup>	144	64	12	6
100 <sup>2</sup>	164	64	19	7
125 <sup>2</sup>	194	70	28	12
450	541	152	163	130
500	596	152	181	152
600	698	178	217	234
700	813	229	250	326
800	920	241	290	490
900	1,020	241	327	602
1000	1,127	300	364	860

1 Only BB 12 A

2 Only BB 12 A and BB 12 C

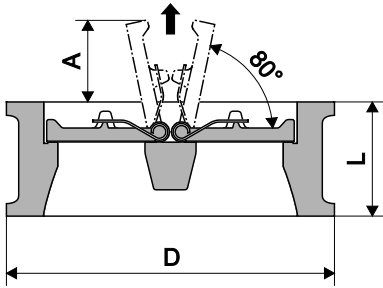

### BB 14, PN 16/CLASS 125

DN	NPS [in]	Dimensions [mm]				Weight [kg]
		D		L <sup>1</sup>	A	
		PN 16	CL 125			
50 <sup>2</sup>	—	109	—	43	8	2.5
65 <sup>2</sup>	—	129	—	46	11	4
80 <sup>2</sup>	—	144	—	64	12	6
100 <sup>3</sup>	—	164	—	64	19	7
125 <sup>3</sup>	—	194	—	70	28	12
450	18	558	549	152	163	138
500	20	620	606	152	181	164
600	24	737	718	178	217	263
700	28	807	776	229	250	321
800	32	914	940	241	290	484
900	36	1,014	1,048	241	327	596
1000	40	1,131	1,095	300	364	865

- 1 The overall length of equipment to ASME corresponds to the overall length to DIN EN 558-1 (DIN 3202 part 3)
- 2 Only BB 14 A
- 3 Only BB 14 A and BB 14 C

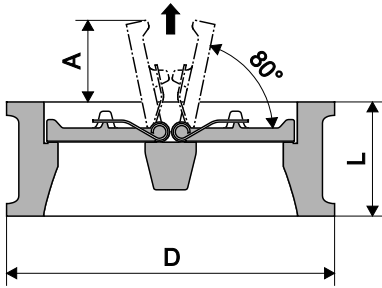

### BB 15, PN 25/CLASS 150

DN	NPS [in]	Dimensions [mm]				A	Weight [kg]
		D		L			
		PN 25	CL 150	PN 25	CL 150		
50 <sup>1</sup>	2	109	105	43	60	8	2.5
65 <sup>1</sup>	2.5	129	124	46	67	11	4
80 <sup>1</sup>	3	144	137	64	73	12	6
100 <sup>2</sup>	4	171	175	64	73	19	7.5
125 <sup>2</sup>	5	196	197	70	86	28	12
450	18	–	549	152 <sup>3</sup>		163	140
500	20	627	606	152 <sup>3</sup>		181	168
600	24	734	718	178 <sup>3</sup>		217	261
700	28	836	776	229 <sup>3</sup>		250	345
800	32	945	940	241 <sup>3</sup>		290	526
900	36	1,045	1,048	241 <sup>3</sup>		327	643
1000	40	1,158	1,095	300 <sup>3</sup>		364	907

1 Only BB 15 A

2 Only BB 15 A and BB 15 C

3 The overall length of equipment to ASME corresponds to the overall length to DIN EN 558-1 (DIN 3202 part 3)

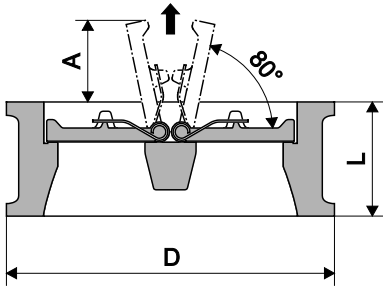

### BB 16, PN 40/CLASS 300

DN	NPS [in]	Dimensions [mm]				A	Weight [kg]
		D		L			
		PN 40	CL 300	PN 40	CL 300		
50 <sup>1</sup>	2	109	111	43	60	8	2.5
65 <sup>1</sup>	2.5	129	130	46	67	11	4
80 <sup>1</sup>	3	144	149	64	73	12	6
100 <sup>2</sup>	4	171	181	64	73	19	7.5
125 <sup>2</sup>	5	196	216	70	86	28	12
450	18	574	597	152 <sup>3</sup>		163	143
500	20	631	654	152 <sup>3</sup>		181	170
600	24	750	775	178 <sup>3</sup>		217	273
700	–	855	–	229	–	250	390
800	–	978	–	241	–	290	577

1 Only BB 16 A

2 Only BB 16 A and BB 16 C

3 The overall length of equipment to ASME corresponds to the overall length to DIN EN 558-1 (DIN 3202 part 3)

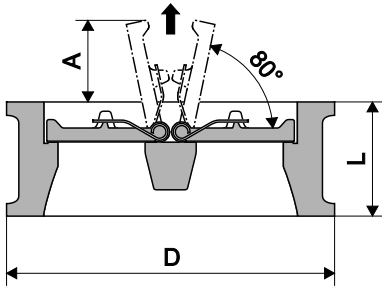

### BB 17, PN 63

DN	NPS [in]	Dimensions [mm]			Weight [kg]
		D	L <sup>1</sup>	A	
50 <sup>2</sup>	2	115	60	0	3.5
65 <sup>2</sup>	2.5	140	67	0	6
80 <sup>2</sup>	3	150	73	5	7
100	4	176	79	4	9
125	5	213	105 <sup>3</sup>	14	21
150	6	250	137	0	31
200	8	312	165	3	52
250	10	367	213	0	78
300	12	427	229	15	128
350	14	489	273	8	205
400	16	546	305	5	265
500	20	660	368	5	472
600	24	768	394	10	670

1 The overall length of the equipment to EN corresponds to the overall length to ASME (API 594)

2 Only BB 17 A

3 The overall length is not standardized.

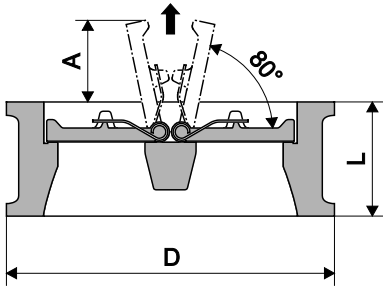

### BB 18, PN 100/CLASS 600

DN	NPS [in]	Dimensions [mm]			Weight [kg]
		D		L <sup>1</sup>	
		PN 100	CL 600		
50 <sup>2</sup>	2	121	111	60	4
65 <sup>2</sup>	2.5	146	130	67	6.5
80 <sup>2</sup>	3	156	149	73	7.5
100	4	183	193	79	10
125	5	220	241	105 <sup>3</sup>	22.5
150	6	260	267	137	32
200	8	327	320	165	56
250	10	394	400	213	89
300	12	461	457	229	150
350	14	515	492	273	228
400	16	575	565	305	294
500	20	708	683	368	543
600	24	819	791	438	847

1 The overall length of the equipment to EN corresponds to the overall length to ASME (API 594)

2 Only BB 18 A

3 The overall length is not standardized.



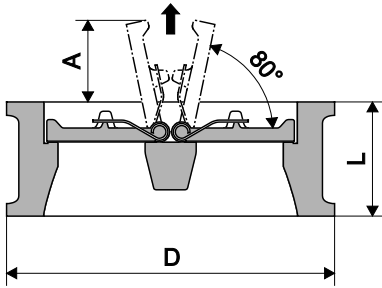

**BB 19, PN 160, CLASS 900**

DN	NPS [in]	Dimensions [mm]				Weight [kg]
		D		L <sup>1</sup>	A	
		PN 160	CLASS 900			
150	6	260	289	159	0	50
200	8	327	359	206	3	83
250	10	391	435	241	0	123
300	12	461	499	292	15	191

<sup>1</sup> The overall length of the equipment to EN corresponds to the overall length to ASME (API 594)

**BB 21 G, PN 6**

DN	Dimensions [mm]			Weight [kg]
	D	L	A	
150	209	76	40	12
200	264	89	64	18.5
250	319	114	87	33
300	375	114	110	44
350	425	127	120	62.5
400	475	140	142	80.5

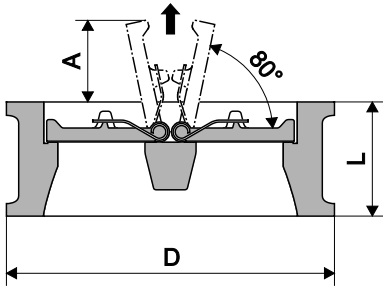

### BB 22, PN 10

DN	Dimensions [mm]			Weight [kg]
	D	L	A	
150	220	76	40	13.5
200	275	89	64	20
250	330	114	87	35
300	380	114	110	45
350	440	127	120	67
400	491	140	142	86

### BB 24, PN 16, CLASS 125

DN	NPS [in]	Dimensions [mm]			Weight [kg]	
		D		L <sup>1</sup>		A
		PN 16	CLASS 125			
150	6	220	222	76	40	13.5
200	8	275	279	89	64	20
250	10	330	340	114	87	35
300	12	386	410	114	110	47
350	14	446	451	127	120	69
400	16	498	514	140	142	88

<sup>1</sup> The overall length of equipment to ASME corresponds to the overall length to DIN EN 558-1 (DIN 3202 part 3)

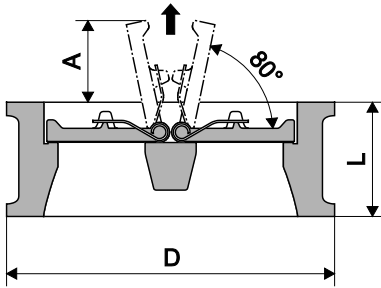

**BB 25, PN 25/CLASS 150**

DN	NPS [in]	Dimensions [mm]				Weight [kg]
		D		L <sup>1</sup>	A	
		PN 25	CLASS 150			
150	6	226	222	76	40	14
200	8	286	279	89	64	22
250	10	343	340	114	87	38
300	12	403	410	114	110	51
350	14	460	451	127	120	73
400	16	517	514	140	142	95

<sup>1</sup> The overall length of equipment to ASME corresponds to the overall length to DIN EN 558-1 (DIN 3202 part 3)

**BB 26, PN 40/CLASS 300**

DN	NPS [in]	Dimensions [mm]				Weight [kg]
		D		L <sup>1</sup>	A	
		PN 40	CLASS 300			
150	6	226	251	76	40	14
200	8	293	308	89	64	23
250	10	355	362	114	87	41
300	12	420	422	114	110	55
350	14	477	486	127	120	79
400	16	549	540	140	142	107

<sup>1</sup> The overall length of equipment to ASME corresponds to the overall length to DIN EN 558-1 (DIN 3202 part 3)

**Weights and dimensions for equipment with dampers**

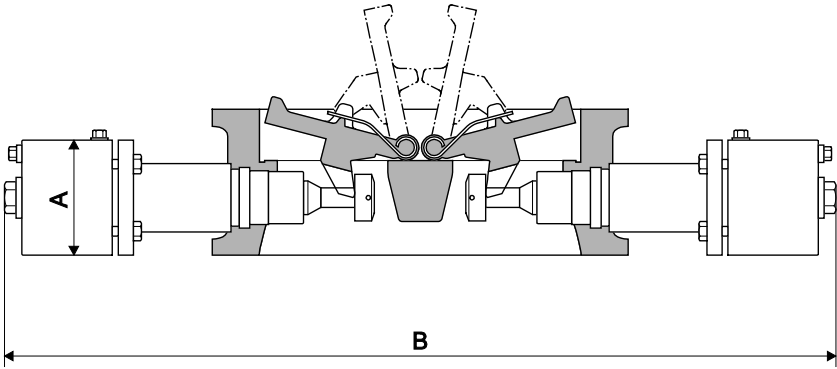

DN	200	250	300	350	400	500	600	700	800
NPS	8	10	12	14	16	20	24	28	32
A [mm]	90				120			140	
B [mm]	600	665	715	755	900	995	1.110	1.220	1.325
Weight [kg]	33	48	60	82	121	197	296	367	530

1 The specifications refer to equipment PN 16. For information on other types please contact the manufacturer.

## Pressure & temperature ratings



For the max. flowrate as a function of the differential pressure see the capacity chart in the data sheet.

### Limiting conditions for BB 1 and BB 2

#### Admissible service pressure [bar] for equipment with body made from grey cast iron (5.1301)

	PN	Temperature [°C]					
		-10/20	100	150	200	250	300
BB 11, BB 21	6	6	6	5.4	4.8	4.2	3.6
BB 12, BB 22	10	10	10	9	8	7	6
BB 14, BB 24	16	16	16	14.4	12.8	11.2	9.6

#### Admissible service pressure [bar] for equipment with body made from carbon steel (1.0460/1.0619)

	PN	Temperature [°C]								
		-10/20	50	100	150	200	300	350	400	450
BB 12, BB 22	10	10	10	9.4	8.9	8.4	7.0	6.5 <sup>1</sup>	6.0 <sup>1</sup>	3.7 <sup>1</sup>
BB 14, BB 24	16	16	16	15	14.2	13.4	11.1	10.4 <sup>1</sup>	9.6 <sup>1</sup>	5.9 <sup>1</sup>
BB 15, BB 25	25	25	25	23.4	22.2	21.0	17.4	16.2 <sup>1</sup>	15.6 <sup>1</sup>	9.2 <sup>1</sup>
BB 16, BB 26	40	40	40	37.4	35.5	33.6	27.8	25.9 <sup>1</sup>	24.0 <sup>1</sup>	14.7 <sup>1</sup>
BB 17	63	63	63	59	55.9	52.9	43.8	40.8 <sup>1</sup>	37.8 <sup>1</sup>	23.8
BB 18	100	100	100	93.6	88.8	84.0	69.6	64.8 <sup>1</sup>	60.0 <sup>1</sup>	36.8
BB 19	160	160	160	149.8	142.1	134.5	111.4	103.7 <sup>1</sup>	96.0 <sup>1</sup>	58.9

<sup>1</sup> Requires special springs made from Inconel.

**Admissible service pressure [bar] at nominal pressure for equipment with body made from stainless steel (1.4404)**

	DN	PN	Temperature [°C]									
			-200/ 20	100	200	300	400	450	475	500	525 <sup>1</sup>	550 <sup>1</sup>
BB 12	50-125	10	10	9.8	8.1	6.4	5.9 <sup>2</sup>	5.6 <sup>2</sup>	5.5 <sup>2</sup>	5.5 <sup>2</sup>	–	–
BB 14	50-125	16	16	15.7	13.0	10.3	9.4 <sup>2</sup>	9.0 <sup>2</sup>	8.9 <sup>2</sup>	8.8 <sup>2</sup>	–	–
BB 15	50-125	25	25	24.5	20.3	16.1	14.7 <sup>2</sup>	14.0 <sup>2</sup>	13.9 <sup>2</sup>	13.7 <sup>2</sup>	–	–
BB 16	50-125	40	40	39.2	32.5	25.8	23.5 <sup>2</sup>	22.4 <sup>2</sup>	22.2 <sup>2</sup>	22.0 <sup>2</sup>	–	–
BB 17	50-100	63	63	61.7	51.2	40.6	37.0 <sup>2</sup>	35.3 <sup>2</sup>	34.9 <sup>2</sup>	34.6 <sup>2</sup>	–	–
BB 18	50-100	100	100	98.0	81.2	64.4	58.8 <sup>2</sup>	56.0 <sup>2</sup>	55.4 <sup>2</sup>	54.9 <sup>2</sup>	–	–

1 Not for equipment DN 50–125.

2 Requires special springs made from Inconel.

If the operating temperatures exceed 300 °C intercrystalline corrosion may occur. Do not subject the equipment to operating temperatures higher than 300 °C unless intercrystalline corrosion can be ruled out.

**Admissible service pressure [bar] for equipment with body made from stainless steel (1.4408)**

	DN	PN	Temperature [°C]									
			-200/ 20	100	200	300	400	450	475	500	525	550
BB 12, BB 22	150-1000	10	10	9.5	7.6	6.4	5.9 <sup>1</sup>	5.7 <sup>1</sup>	5.6 <sup>1</sup>	5.5 <sup>1</sup>	5.2 <sup>1</sup>	5.2 <sup>1</sup>
BB 14, BB 24	150-1000	16	16	15.2	12.1	10.3	9.4 <sup>1</sup>	9.1 <sup>1</sup>	9.0 <sup>1</sup>	8.9 <sup>1</sup>	8.4 <sup>1</sup>	8.3 <sup>1</sup>
BB 15, BB 25	150-1000	25	25	23.8	18.9	16.1	14.7 <sup>1</sup>	14.1 <sup>1</sup>	14.0 <sup>1</sup>	13.9 <sup>1</sup>	13.1 <sup>1</sup>	12.9 <sup>1</sup>
BB 16, BB 26	150-1000	40	40	38.1	30.2	25.8	23.5 <sup>1</sup>	22.6 <sup>1</sup>	22.4 <sup>1</sup>	22.2 <sup>1</sup>	20.9 <sup>1</sup>	20.7 <sup>1</sup>
BB 17	125-600	63	63	60.3	47.6	40.6	37.0 <sup>1</sup>	35.6 <sup>1</sup>	35.3 <sup>1</sup>	34.9 <sup>1</sup>	32.9 <sup>1</sup>	32.6 <sup>1</sup>
BB 18	125-600	100	100	95.2	75.6	64.4	58.8 <sup>1</sup>	56.6 <sup>1</sup>	56.0 <sup>1</sup>	55.4 <sup>1</sup>	52.3 <sup>1</sup>	51.7 <sup>1</sup>
BB 19	150-300	160	160	152.4	121.0	103.1	94.1 <sup>1</sup>	90.5 <sup>1</sup>	89.6 <sup>1</sup>	88.7 <sup>1</sup>	83.7 <sup>1</sup>	82.8 <sup>1</sup>

1 Requires special springs made from Inconel.

If the operating temperatures exceed 300 °C intercrystalline corrosion may occur. Do not subject the equipment to operating temperatures higher than 300 °C unless intercrystalline corrosion can be ruled out.

## Limiting conditions for BB 1 ASME and BB 2 ASME

### Admissible service pressure [bar] for equipment with body made from carbon steel (A105/A216WCB)

	Class	Temperature [°C]							
		-29/ 20	100	200	250	300	350	400	425
BB 15, BB 25	150	19.6	17.7	13.8	12.1	10.2	8.4 <sup>1</sup>	6.5 <sup>1</sup>	5.5 <sup>1</sup>
BB 16, BB 26	300	51.1	46.6	43.8	41.9	39.8	37.6 <sup>1</sup>	34.7 <sup>1</sup>	28.8 <sup>1</sup>
BB 18	600	102.1	93.2	87.6	83.9	79.6	75.1 <sup>1</sup>	69.4 <sup>1</sup>	57.5 <sup>1</sup>
BB 19	900	153.2	139.8	131.4	125.8	119.5	112.7 <sup>1</sup>	104.2 <sup>1</sup>	86.3 <sup>1</sup>

<sup>1</sup> Requires special springs made from Inconel.

### Admissible service pressure [bar] for equipment with body made from stainless steel (A182F316L)

	Class	Temperature [°C]							
		-200/ 20	100	200	250	300	350	400	450
BB 15	150	15.9	13.3	11.2	10.5	10.0	8.4 <sup>1</sup>	6.5 <sup>1</sup>	4.6 <sup>1</sup>
BB 16	300	41.4	34.8	29.2	27.5	26.1	25.1 <sup>1</sup>	24.3 <sup>1</sup>	23.4 <sup>1</sup>
BB 18	600	82.7	69.6	58.3	54.9	52.1	50.1 <sup>1</sup>	48.6 <sup>1</sup>	46.8 <sup>1</sup>

<sup>1</sup> Requires special springs made from Inconel.

If the operating temperatures exceed 300 °C intercrystalline corrosion may occur. Do not subject the equipment to operating temperatures higher than 300 °C unless intercrystalline corrosion can be ruled out.

### Admissible service pressure [bar] for equipment with body made from stainless steel (A351 CF8M)

	Class	Temperature [°C]									
		-200/ 20	100	200	250	300	350	400	450	500	538
BB 15, BB 25	150	19.0	16.2	13.7	12.1	10.2	8.4 <sup>1</sup>	6.5 <sup>1</sup>	4.6 <sup>1</sup>	2.8 <sup>1</sup>	1.4 <sup>1</sup>
BB 16, BB 26	300	49.6	42.2	35.7	33.4	31.6	30.3 <sup>1</sup>	29.4 <sup>1</sup>	28.8 <sup>1</sup>	28.2 <sup>1</sup>	25.2 <sup>1</sup>
BB 18	600	99.3	84.4	71.3	66.8	63.2	60.7 <sup>1</sup>	58.9 <sup>1</sup>	57.7 <sup>1</sup>	56.5 <sup>1</sup>	50.0 <sup>1</sup>
BB 19	900	148.9	126.8	107.0	100.2	95.0	91.3 <sup>1</sup>	88.2 <sup>1</sup>	86.6 <sup>1</sup>	82.1 <sup>1</sup>	72.3 <sup>1</sup>

<sup>1</sup> Requires special springs made from Inconel.

If the operating temperatures exceed 300 °C intercrystalline corrosion may occur. Do not subject the equipment to operating temperatures higher than 300 °C unless intercrystalline corrosion can be ruled out.

### Limiting conditions for equipment with optional extras

#### Limiting conditions for equipment with anti-corrosion lining

The admissible limiting conditions for equipment with anti-corrosion lining are indicated in the following tables:

Lining	Temperature range [°C]
Vestosint	-10 to +70
Hard rubber	-10 to +90

#### Limiting conditions for equipment with dampers

The admissible limiting conditions for equipment with dampers are indicated in the following tables:

DN	200	250	300	350	400	500	600	700	800
Service pressure [barg]	16	16	13	9	13	9	5	8	6
Pressure at inlet side <sup>1</sup> [bar]	0.5								
Temperature [°C]	110								

1 With pump switched off

#### Limiting conditions for equipment with soft sealing connection

Type	Temperature range [°C]
EPDM	-40 to +150
FPM (FKM)	-25 to +200
NBR	-30 to +110
PTFE	-25 to +200



## **Manufacturer's declaration**

For more information on the Conformity Assessment according to European rules refer to our Declaration of Conformity or our Declaration by Manufacturer.

To download the current Declaration of Conformity or Declaration by Manufacturer go to [www.gestra.com/documents](http://www.gestra.com/documents) or contact:

### **GESTRA AG**

Münchener Straße 77

28215 Bremen

Germany

Telefon +49 421 3503-0

Telefax +49 421 3503-393

E-Mail [info@de.gestra.com](mailto:info@de.gestra.com)

Web [www.gestra.de](http://www.gestra.de)

This declaration is no longer valid if modifications are made to the equipment without consultation with us.







Agencies all over the world: [www.gestra.de](http://www.gestra.de)

## **GESTRA AG**

Münchener Straße 77

28215 Bremen

Germany

Telefon +49 421 3503-0

Telefax +49 421 3503-393

E-Mail [info@de.gestra.com](mailto:info@de.gestra.com)

Web [www.gestra.de](http://www.gestra.de)

810677-05/08-2016 kx\_mm (808531-05) © GESTRA AG Bremen Printed in Germany