



OPTIFLUX 5000 Quick Start

Electromagnetic flowmeter in flanged version

The documentation is only complete when used in combination with the relevant documentation for the signal converter.

1	Safety instructions	3
<hr/>		
2	Installation	4
<hr/>		
2.1	Scope of delivery.....	4
2.2	Device description	5
2.3	Nameplates (examples)	6
2.4	Storage	6
2.5	Transport	7
2.6	Pre-installation requirements	7
2.7	General requirements	8
2.7.1	Vibrations	8
2.7.2	Magnetic field.....	8
2.8	Installation conditions	9
2.8.1	Inlet and outlet	9
2.8.2	Bends in 2 or 3 dimensions.....	9
2.8.3	T-section	10
2.8.4	Bends	10
2.8.5	Open discharge	11
2.8.6	Flange deviation	11
2.8.7	Pump	11
2.8.8	Control valve	12
2.8.9	Air venting and vacuum forces	12
2.8.10	Mounting position.....	13
2.9	Mounting	14
2.9.1	Torques and pressures.....	14
<hr/>		
3	Electrical connections	16
<hr/>		
3.1	Safety instructions.....	16
3.2	Grounding	16
3.3	Virtual reference for IFC 300 (C, W and F version)	17
3.4	Connection diagrams	17
<hr/>		
4	Technical data	18
<hr/>		
4.1	Dimensions and weights	18
<hr/>		
5	Notes	23
<hr/>		

Warnings and symbols used



DANGER!

This information refers to the immediate danger when working with electricity.



DANGER!

These warnings must be observed without fail. Even partial disregard of this warning can lead to serious health problems and even death. There is also the risk of seriously damaging the device or parts of the operator's plant.



WARNING!

Disregarding this safety warning, even if only in part, poses the risk of serious health problems. There is also the risk of damaging the device or parts of the operator's plant.



CAUTION!

Disregarding these instructions can result in damage to the device or to parts of the operator's plant.



INFORMATION!

These instructions contain important information for the handling of the device.



HANDLING

- This symbol designates all instructions for actions to be carried out by the operator in the specified sequence.

➔ **RESULT**

This symbol refers to all important consequences of the previous actions.

Safety instructions for the operator



CAUTION!

Installation, assembly, start-up and maintenance may only be performed by appropriately trained personnel. The regional occupational health and safety directives must always be observed.



LEGAL NOTICE!

The responsibility as to the suitability and intended use of this device rests solely with the user. The supplier assumes no responsibility in the event of improper use by the customer. Improper installation and operation may lead to loss of warranty. In addition, the "Terms and Conditions of Sale" apply which form the basis of the purchase contract.



INFORMATION!

- *Further information can be found in the manual, on the data sheet, in special manuals, certificates and on the manufacturer's website.*
- *If you need to return the device to the manufacturer or supplier, please fill out the form contained in the manual and send it with the device. Unfortunately, the manufacturer cannot repair or inspect the device without the completed form.*

2.1 Scope of delivery



INFORMATION!

Do a check of the packing list to make sure that you have all the elements given in the order.



INFORMATION!

Inspect the packaging carefully for damages or signs of rough handling. Report damage to the carrier and to the local office of the manufacturer.



INFORMATION!

The remote version will arrive in two cartons. One carton contains the signal and one carton contains the flow.



Figure 2-1: Scope of delivery

- ① Ordered flowmeter
- ② Product documentation
- ③ Factory calibration report
- ④ Grounding rings (optional)
- ⑤ Signal cable (remote versions only)



INFORMATION!

Assembly materials and tools are not part of the delivery. Use the assembly materials and tools in compliance with the applicable occupational health and safety directives.

2.2 Device description

Electromagnetic flowmeters are designed exclusively to measure the flow and conductivity of electrically conductive, liquid media.



INFORMATION!

Product specific information and extensive product specification is available using PICK, the Product Information Center KROHNE web-tool.

PICK can be found via the service menu button on the KROHNE.com website.



The following versions are available:

- Compact version (the signal is mounted directly on the flow)
- Remote version (a flow with a connection box and a separate signal, connected via field current- and signal cable)

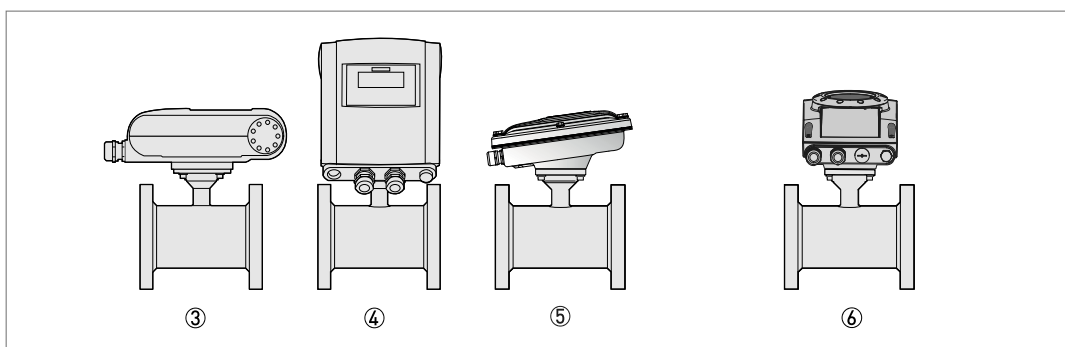
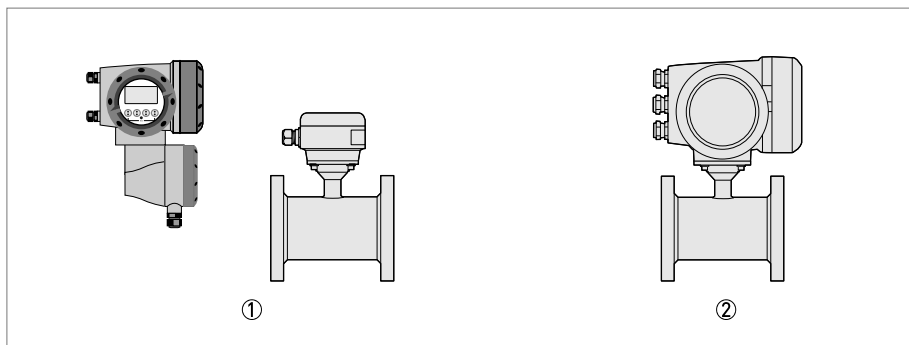

- ① Remote version
- ② Compact version with IFC 300 signal converter
- ③ Compact version with IFC 100 (0°) signal converter
- ④ Compact version with IFC 100 (45°) signal converter
- ⑤ Compact version with stainless steel IFC 100 (10°) signal converter
- ⑥ Compact version with IFC 050 (10°) signal converter

2.3 Nameplates (examples)



INFORMATION!

Look at the device nameplate to ensure that the device is delivered according to your order. Check for the correct supply voltage printed on the nameplate..

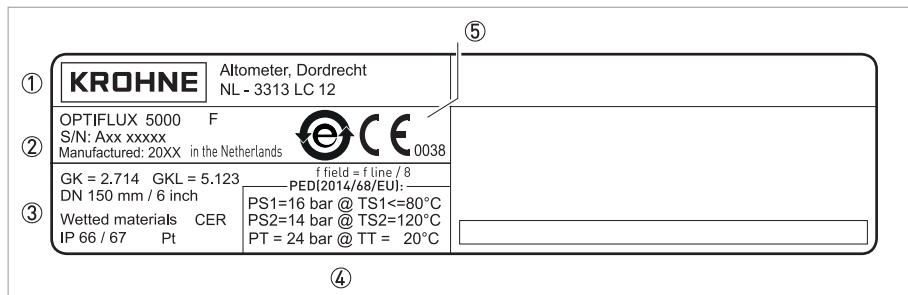

- ① Name and address of the manufacturer
- ② Type designation of the flowmeter
- ③ Calibration data
- ④ PED data
- ⑤ Disposal logo and CE sign with number(s) of notified body/bodies

2.4 Storage

- Store the device in a dry and dust-free location.
- Avoid lasting direct exposure to the sun.
- Store the device in its original packaging.
- Storage temperature: -50...+70°C / -58...+158°F

2.5 Transport

Signal converter

- No special requirements.

Compact version

- Do not lift the device by the signal converter housing.
- Do not use lifting chains.
- To transport flange devices, use lifting straps. Wrap these around both process connections.

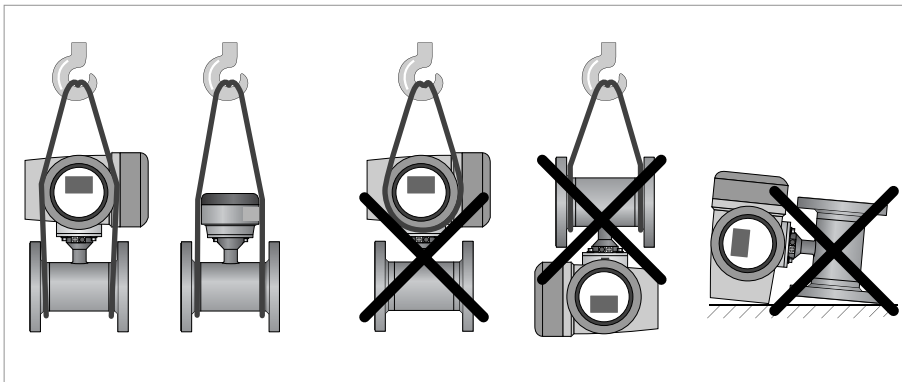

Figure 2-2: Transport

2.6 Pre-installation requirements

Make sure that you have all necessary tools available:

- Allen key (4 mm)
- Small screwdriver
- Wrench for cable glands
- Wrench for wall mounting bracket (remote version only)
- Torque wrench for installing flowmeter in pipeline

2.7 General requirements



INFORMATION!

The following precautions must be taken to ensure reliable installation.

- Make sure that there is adequate space to the sides.
- Protect the signal from direct sunlight and install a sun shade if necessary.
- Signal installed in control cabinets require adequate cooling, e.g. by fan or heat exchanger.
- Do not expose the signal to intense vibration. The flowmeters are tested for a vibration level in accordance with IEC 60068-2-64.

2.7.1 Vibrations

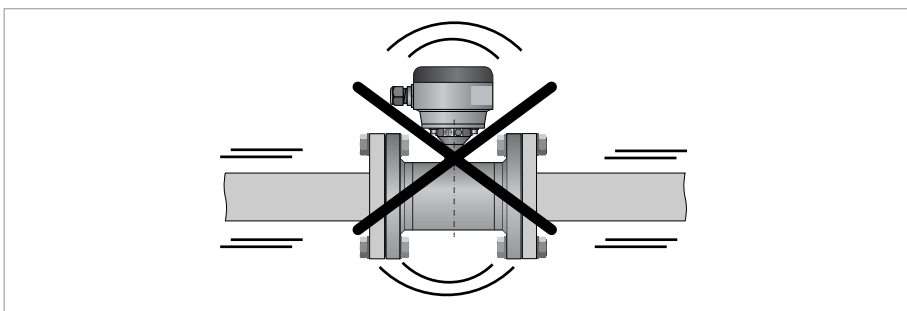

Figure 2-3: Avoid vibrations

2.7.2 Magnetic field

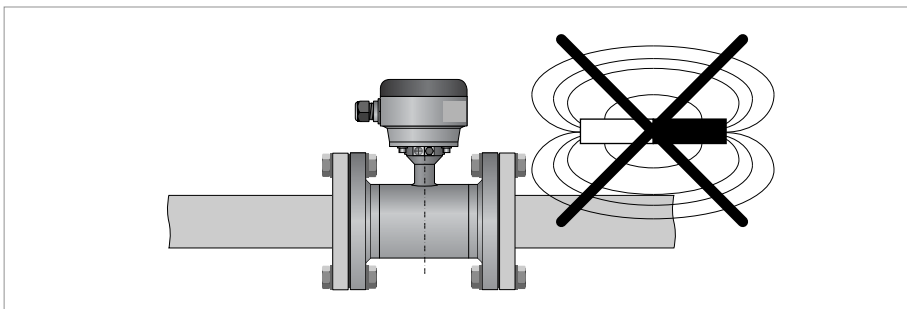

Figure 2-4: Avoid magnetic field

2.8 Installation conditions

2.8.1 Inlet and outlet

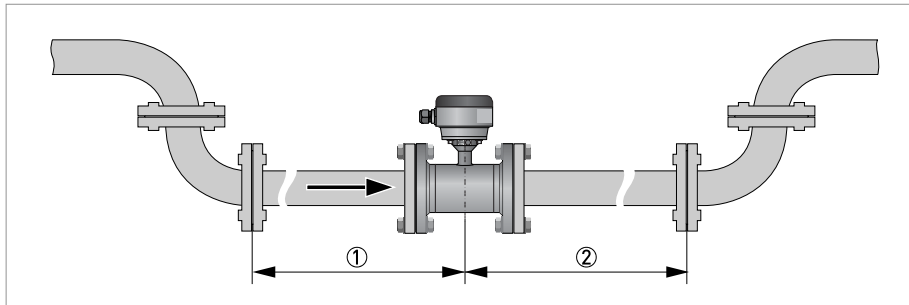

Figure 2-5: Recommended inlet and outlet

- ① Refer to chapter "Bends in 2 or 3 dimensions"
- ② ≥ 2 DN



INFORMATION!

Sensors of type VN02 up to DN10:

The inlet and outlet sections are enclosed inside the sensor.

2.8.2 Bends in 2 or 3 dimensions

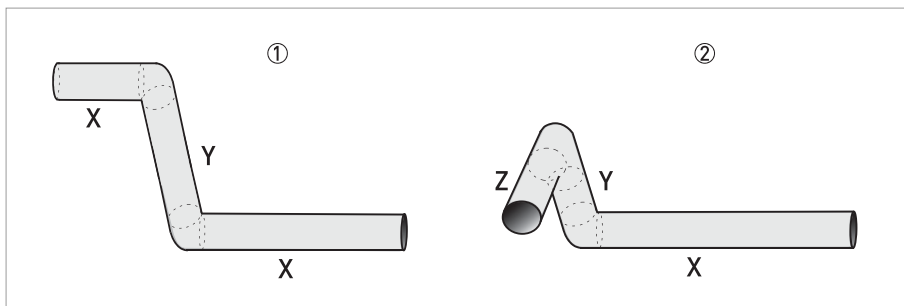

Figure 2-6: 2 and/or 3 dimensional bends upstream of the flowmeter

- ① 2 dimensions = X/Y
- ② 3 dimensions = X/Y/Z

Inlet length: using bends in 2 dimensions: ≥ 5 DN; when having bends in 3 dimensions: ≥ 10 DN



INFORMATION!

2 dimensional bends occur in a vertical **or** horizontal plane (X/Y) only, while 3 dimensional bends occur in both vertical **and** horizontal plane (X/Y/Z).

2.8.3 T-section

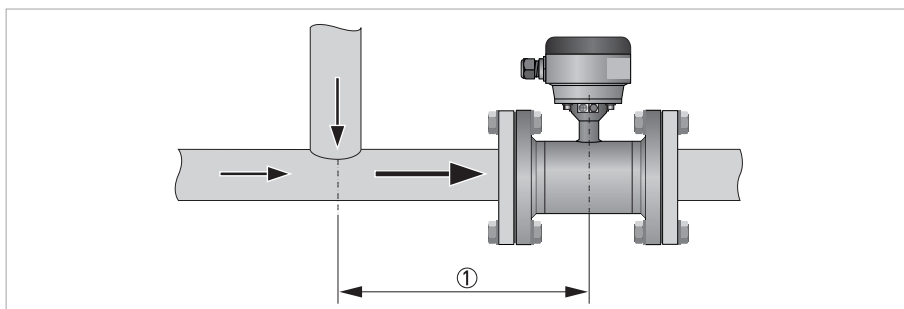

Figure 2-7: Distance behind a T-section

① ≥ 10 DN

2.8.4 Bends

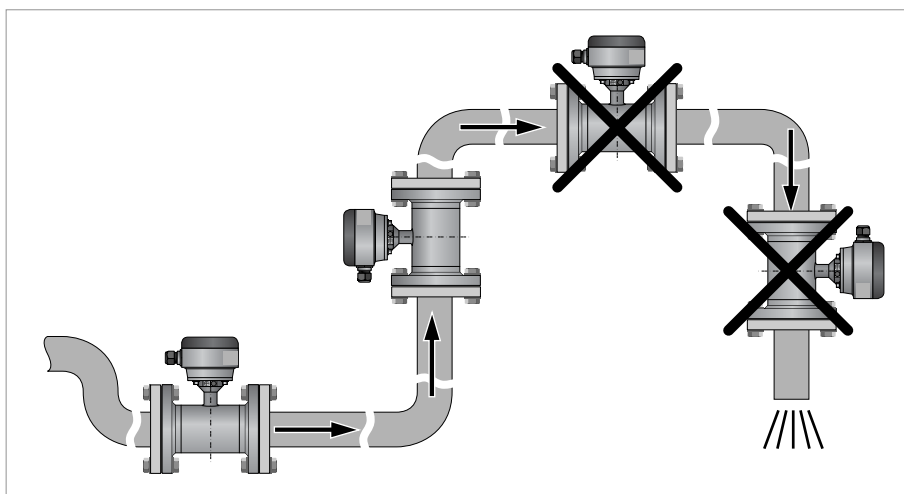

Figure 2-8: Installation in bending pipes (90°)

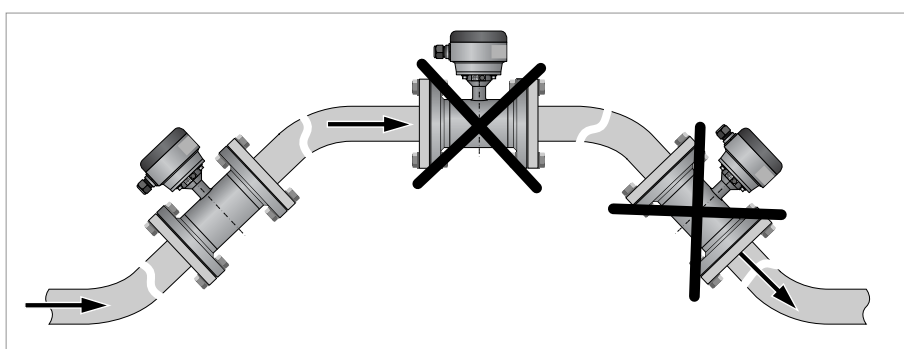

Figure 2-9: Installation in bending pipes (45°)



CAUTION!
Avoid draining or partial filling of the flow

2.8.5 Open discharge

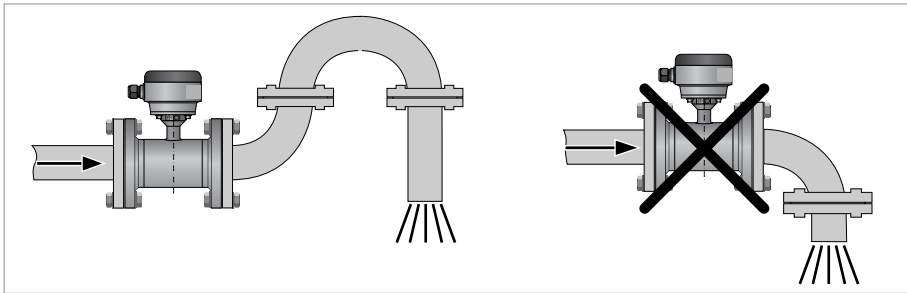

Figure 2-10: Installation in front of an open discharge

2.8.6 Flange deviation



CAUTION!

Max. permissible deviation of pipe flange faces:

$$L_{max} - L_{min} \leq 0.5 \text{ mm} / 0.02''$$

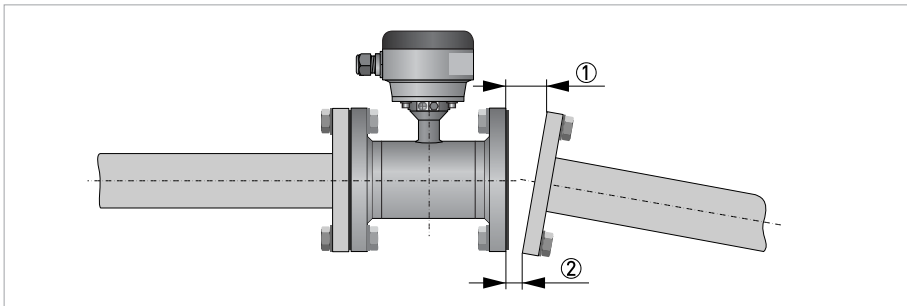

Figure 2-11: Flange deviation

- ① L_{max}
- ② L_{min}

2.8.7 Pump

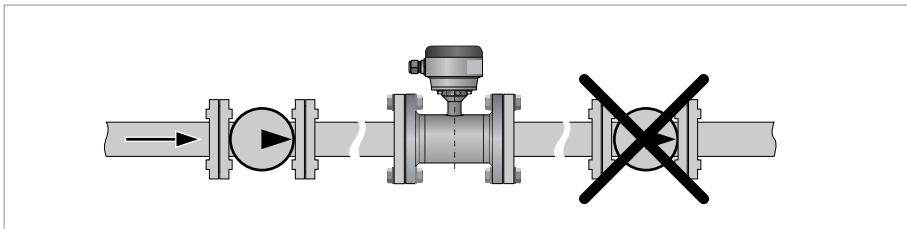

Figure 2-12: Installation behind a pump

2.8.8 Control valve

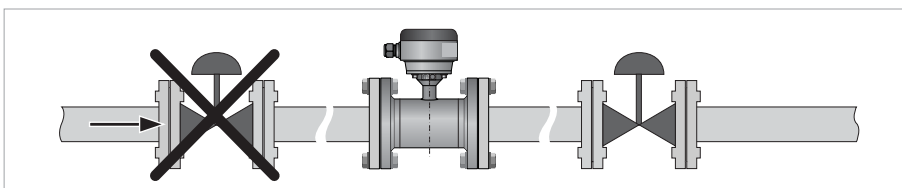

Figure 2-13: Installation in front of a control valve

2.8.9 Air venting and vacuum forces

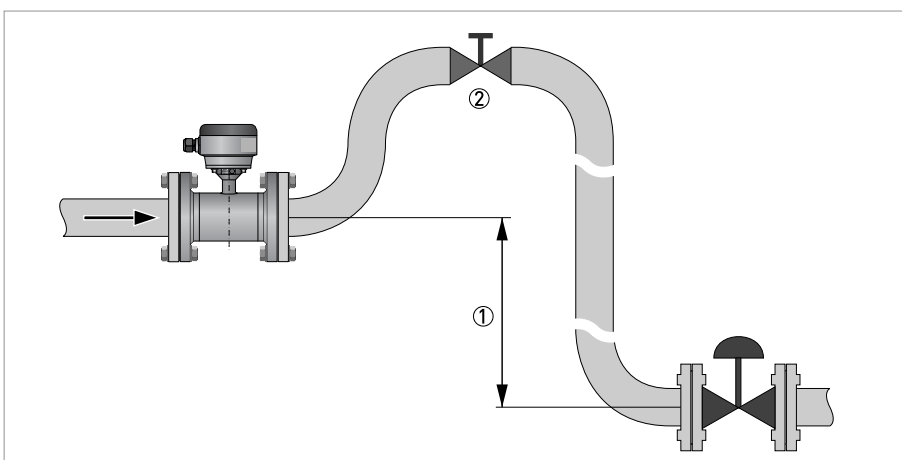

Figure 2-14: Air venting

- ① $\geq 5 \text{ m} / 17 \text{ ft}$
- ② Air ventilation point

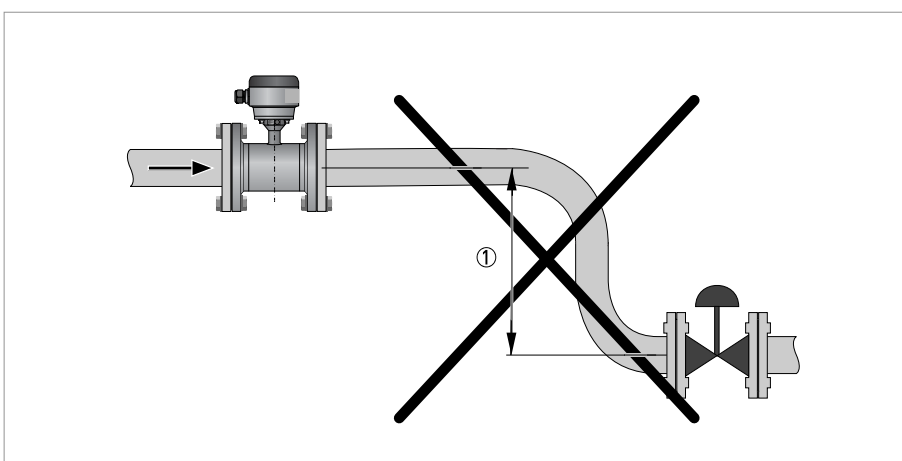

Figure 2-15: Vacuum

- ① $\geq 5 \text{ m} / 17 \text{ ft}$

2.8.10 Mounting position

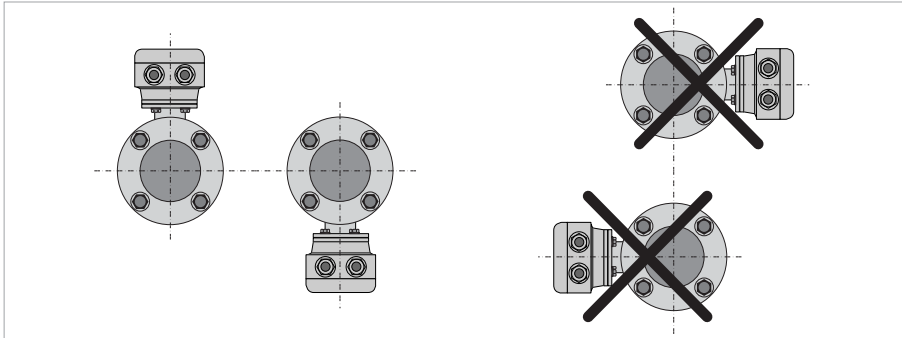

Figure 2-16: Mounting position

- Install flow sensor in line with the pipe axis.
- Pipe flange faces must be parallel to each other.

2.9 Mounting



CAUTION!

Please take care to use the proper gasket to prevent damaging the liner of the flowmeter. In general, the use of spiral wound gaskets is not advised, as it could severely damage the liner of the flowmeter.

2.9.1 Torques and pressures

Tighten the bolts in fixed order, see picture:

- Step 1: by hand
- Step 2: approx. 10% of max. torque
- Step 3: approx. 25% of max. torque
- Step 4: approx. 50% of max. torque
- Step 5: approx. 80% of max. torque
- Step 6: 100% of max. torque given in table

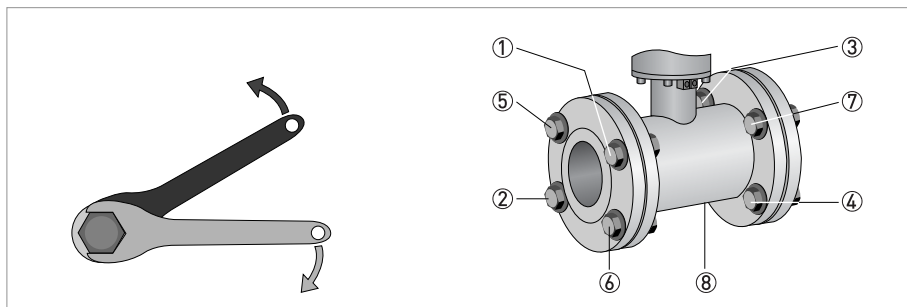

INFORMATION!

Diameters DN80 to DN300 have more bolts than the drawing in the picture above shows. Please continue in the same sequence to tighten the other bolts.



CAUTION!

With the instrument, 4 PTFE gaskets are delivered (2 gaskets to be used with installation, 2 as spare). There are no other gaskets required.

The specified torque values are dependent on variables (temperature, bolt material, gasket material, lubricants, etc.) which are not within the control of the manufacturer. Therefore the values should be regarded as indicative only.

The torque values in the following tables are based 8.8 bolts and a friction coefficient 0.14.

EN 1092-1

Nominal size DN [mm]	Pressure rating	Bolts	Recommended torque [Nm]	
			Min.	Max.
15	PN 40	4 x M 12	50	70
25	PN 40	4 x M 12	50	70
40	PN 40	4 x M 16	100	175
50	PN 40	4 x M 16	100	175
80	PN 40	8 x M 16	100	175
100	PN 16	8 x M 16	100	175
150	PN 16	8 x M 20	200	340
200	PN 10	8 x M 20	200	340
250	PN 10	12 x M 20	250	340
300	PN 10	12 x M 20	250	340

ASME B 16.5

Nominal size [inch]	Flange class [lb]	Bolts	Recommended torque [ftlb]	
			Min.	Max.
½	300	4 x ½"	40	80
1	150 / 300	4 x ½"	40	80
1 ½	150 / 300	4 x ½"	60	80
2	150 / 300	4 x 5/8"	80	160
3	150 / 300	4 x 5/8"	100	160
4	150	8 x 5/8"	100	160
6	150	8 x ¾"	150	280
8	150	8 x ¾"	200	280
10	150	12 x 7/8"	250	450
12	150	12 x 7/8"	300	450

3.1 Safety instructions



DANGER!

All work on the electrical connections may only be carried out with the power disconnected.
Take note of the voltage data on the nameplate!



DANGER!

Observe the national regulations for electrical installations!



DANGER!

For devices used in hazardous areas, additional safety notes apply; please refer to the Ex documentation.



WARNING!

Observe without fail the local occupational health and safety regulations.
Any work done on the electrical components of the measuring device may only be carried out by properly trained specialists.



INFORMATION!

Look at the device nameplate to ensure that the device is delivered according to your order.
Check for the correct supply voltage printed on the nameplate.

3.2 Grounding



DANGER!

The device must be grounded in accordance with regulations in order to protect personnel against electric shocks.

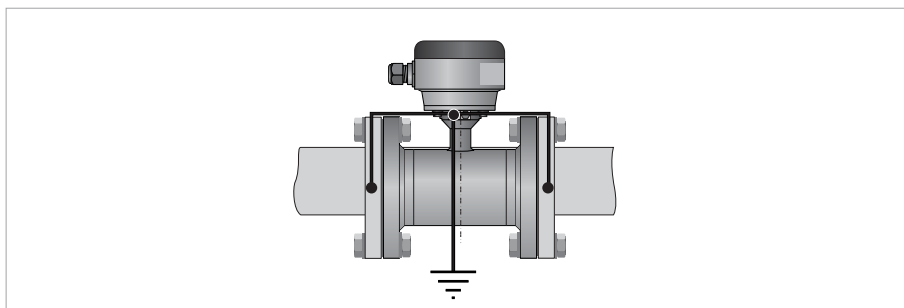

Figure 3-1: Grounding

① Metal pipelines, not internally coated. Grounding without grounding rings.



INFORMATION!

Grounding can be omitted with Virtual reference (option on IFC 300). For detailed information refer to Virtual reference for IFC 300 (C, W and F version) on page 17.

3.3 Virtual reference for IFC 300 (C, W and F version)

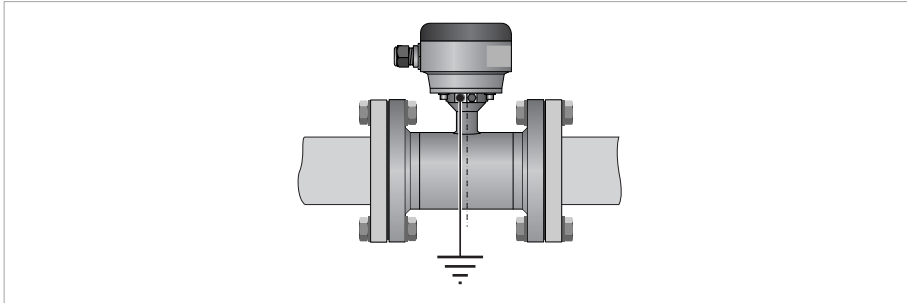

Figure 3-2: Virtual reference

Minimum requirements:

- Size: \geq DN10 / 3/8"
- Electrical conductivity: \geq 200 μ S/cm
- Signal cable: max. 50 m / 164 ft, type DS

3.4 Connection diagrams



INFORMATION!

For the connection diagrams the documentation of the applicable signal converter.

4.1 Dimensions and weights

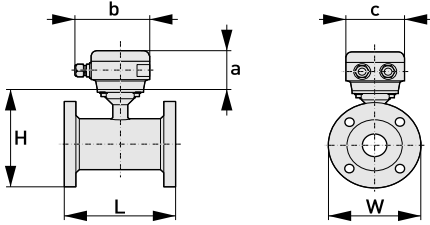
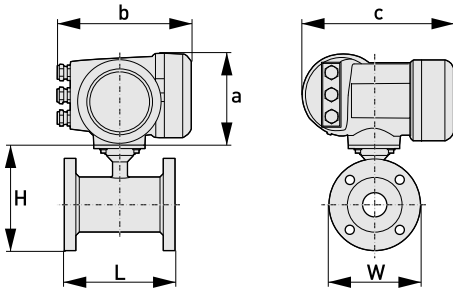
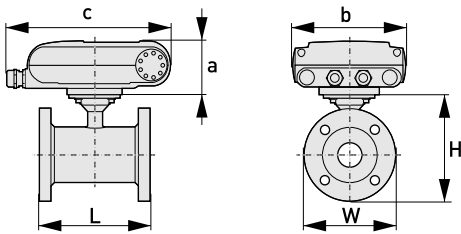
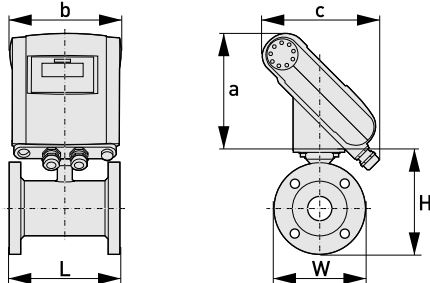
<p>Remote version</p>		<p>a = 88 mm / 3.5"</p> <p>b = 139 mm / 5.5" ①</p> <p>c = 106 mm / 4.2"</p> <p>Total height = H + a</p>
<p>Compact version with: IFC 300</p>		<p>a = 155 mm / 6.1"</p> <p>b = 230 mm / 9.1" ①</p> <p>c = 260 mm / 10.2"</p> <p>Total height = H + a</p>
<p>Compact version with: IFC 100 (0°)</p>		<p>a = 82 mm / 3.2"</p> <p>b = 161 mm / 6.3"</p> <p>c = 257 mm / 10.1" ①</p> <p>Total height = H + a</p>
<p>Compact version with: IFC 100 (45°)</p>		<p>a = 186 mm / 7.3"</p> <p>b = 161 mm / 6.3"</p> <p>c = 184 mm / 7.3" ①</p> <p>Total height = H + a</p>

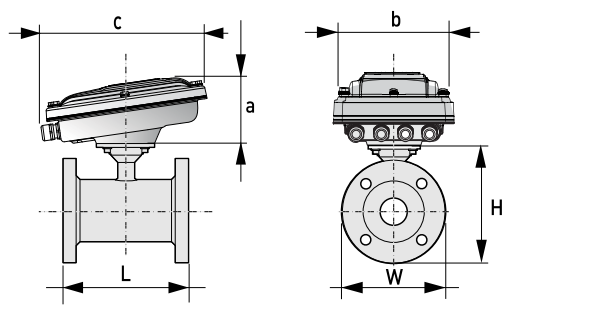
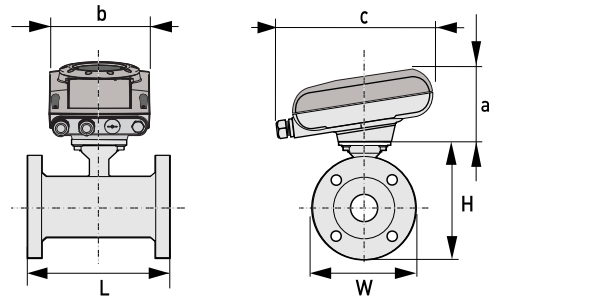
<p>Compact version with stainless steel IFC 100 (10°)</p>		<p>a = 100 mm / 4" b = 187 mm / 7.36" ① c = 270 mm / 10.63" Total height = H + a</p>
<p>Compact version with: IFC 050 (10°)</p>		<p>a = 100mm / 4" b = 157 mm / 6.18" ① c = 260 mm / 10.24" Total height = H + a</p>

① The value may vary depending on the used cable glands.

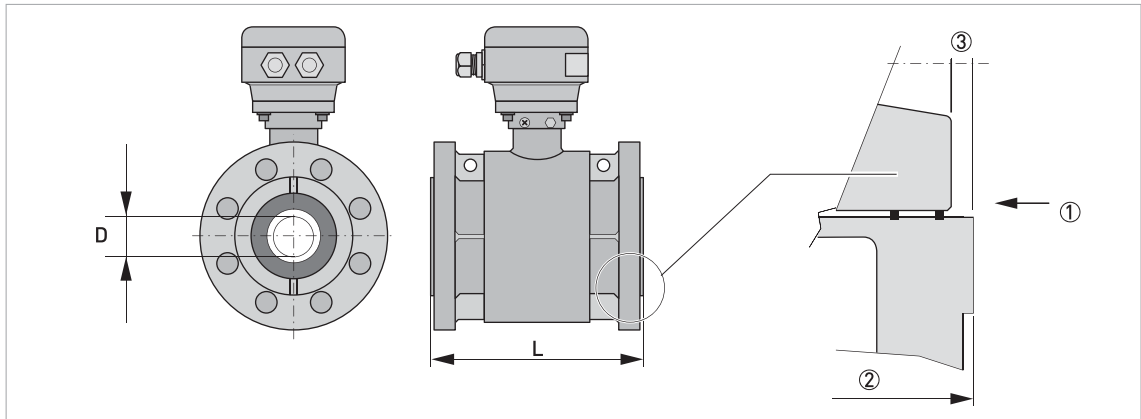

Figure 4-1: Construction details

- ① Detail ceramics, flange and gaskets, see options in following illustration
- ② Length tolerances (see table on following pages)
- ③ Gasket area

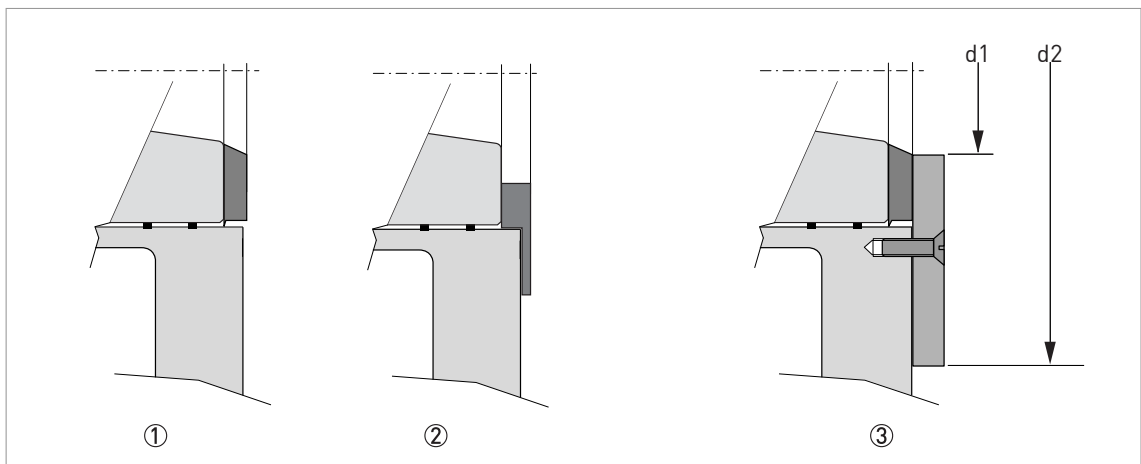

Figure 4-2: Details of gasket options

- ① Sealing ring: PTFE (white)
Optional: conductive PTFE (grey) / Gylon 3504 (blue)
- ② Sealing ring for rounded counter flanges: filled PTFE (blue)
- ③ DN150...300 / 6...12"; optional spacer ring with gasket

**INFORMATION!**

- All data given in the following tables are based on standard versions of the flow only.
- Especially for smaller nominal sizes of the flow, the signal can be bigger than the .
- Note that for other pressure ratings than mentioned, the dimensions may be different.
- For full information on signal dimensions see relevant documentation.

EN 1092-1

Size	Dimensions [mm]							Approx. weight [kg]
DN	L + *	tolerance	H	W	D	Ød1	Ød2	
15	150	A	127	95	12	-	-	3
25	150	A	143	115	20	-	-	4
40	150	A	168	150	30	-	-	6
50	200	A	184	165	40	-	-	9
80	200	A	217	200	60	-	-	15
100	250	A	242	220	80	-	-	21
150	250	B	355	283	150	150	215	37
200	300	B	396	342	200	198	270	53
250	350	B	458	395	250	250	322	87
300	450	B	493	445	300	300	375	145

**INFORMATION!***L + **

- Add approximately 2 x 7.5 mm to L when using spacer rings (option for DN150...300).
- Add approximately 2 x 1.45 mm to L when using filled blue PTFE gaskets (optional).

**INFORMATION!***Tolerances A & B*

- A = + 0.8 / - 0.4 mm; + 0.031 / - 0.016 inches
- B = + 0.5 / - 1.0 mm; + 0.02 / - 0.04 inches

ASME B 16.5 150 lb

Size	Dimensions [inches]							Approx. weight [lb]
inch	L + *	tolerance	H	W	D	Ød1	Ød2	
1"	5.91	A	5.47	4.25	0.79	-	-	8.8
1½"	5.91	A	6.18	5	1.18	-	-	13.2
2"	7.87	A	6.89	6	1.57	-	-	19.8
3"	7.87	A	8.39	7.5	2.36	-	-	33.1
4"	9.84	A	9.65	9	3.15	-	-	46.3
6"	9.84	B	13.98	11	5.91	6.06	8.46	81.6
8"	11.81	B	15.59	13.5	7.80	7.99	10.63	116.8
10"	13.78	B	18.03	16	9.84	10.08	12.68	191.8
12"	17.72	B	19.41	19	11.81	12.05	14.76	366

ASME B 16.5 300 lb

Size	Dimensions [inches]							Approx. weight [lb]
inch	L + *	tolerance	H	W	D	Ød1	Ød2	
½"	5.91	A	5.0	3.74	0.47	-	-	6.8
1"	5.91	A	5.91	4.92	0.79	-	-	8.8
2"	7.87	A	7.20	6.50	1.57	-	-	22.9
3"	7.87	A	8.86	8.27	2.36	-	-	40.6
1½": not possible because of ASTM-NUT								

**INFORMATION!***L + **

- Add approximately 2 x 0.3" to L when using spacer rings (option for 6"...12").
- Add approximately 2 x 0.055" to L when using filled blue PTFE gaskets (optional).

**INFORMATION!***Tolerances A & B*

- A = + 0.8 / - 0.4 mm; + 0.031 / - 0.016 inches
- B = + 0.5 / - 1.0 mm; + 0.02 / - 0.04 inches

**CAUTION!**

- Pressures at 20°C / 68°F.
- For higher temperatures, the pressure and temperature ratings are as per ASME B16.5.





KROHNE – Process instrumentation and measurement solutions

- Flow
- Level
- Temperature
- Pressure
- Process Analysis
- Services

Head Office KROHNE Messtechnik GmbH
Ludwig-Krohne-Str. 5
47058 Duisburg (Germany)
Tel.: +49 203 301 0
Fax: +49 203 301 10389
info@krohne.com

The current list of all KROHNE contacts and addresses can be found at:
www.krohne.com

KROHNE