



OPTIFLUX 6000 Quick Start

Electromagnetic flow sensor
for hygienic and sanitary applications

The documentation is only complete when used in combination with the relevant documentation for the signal converter.

1	Safety instructions	3
<hr/>		
2	Installation	4
<hr/>		
2.1	Scope of delivery	4
2.2	Device description	5
2.3	Nameplates (examples)	6
2.4	Storage	7
2.5	Transport	7
2.6	Pre-installation requirements	8
2.7	General requirements	8
2.7.1	Vibration	8
2.7.2	Magnetic field	8
2.8	Installation conditions	9
2.8.1	Inlet and outlet	9
2.8.2	Bends in 2 or 3 dimensions	9
2.8.3	Bends	10
2.8.4	T-section	11
2.8.5	Open discharge	11
2.8.6	Control valve	12
2.8.7	Pump	12
2.8.8	Air venting and vacuum forces	13
2.8.9	Mounting requirements for self-draining	14
2.8.10	Flange deviation	15
2.8.11	Mounting position	15
2.9	Mounting	16
2.9.1	Torques and pressures	16
2.9.2	EHEDG applications	17
2.9.3	Installation of weld-on versions	17
2.9.4	Cleaning	17
2.9.5	Temperatures	18
<hr/>		
3	Electrical connections	19
<hr/>		
3.1	Safety instructions	19
3.2	Grounding	19
3.3	Virtual reference for IFC 300 (C, W and F version)	20
3.4	Connection diagrams	20
<hr/>		
4	Technical data	21
<hr/>		
4.1	Dimensions and weights	21
<hr/>		
5	Notes	35
<hr/>		

Warnings and symbols used



DANGER!

This information refers to the immediate danger when working with electricity.



DANGER!

These warnings must be observed without fail. Even partial disregard of this warning can lead to serious health problems and even death. There is also the risk of seriously damaging the device or parts of the operator's plant.



WARNING!

Disregarding this safety warning, even if only in part, poses the risk of serious health problems. There is also the risk of damaging the device or parts of the operator's plant.



CAUTION!

Disregarding these instructions can result in damage to the device or to parts of the operator's plant.



INFORMATION!

These instructions contain important information for the handling of the device.



HANDLING

- This symbol designates all instructions for actions to be carried out by the operator in the specified sequence.

➔ **RESULT**

This symbol refers to all important consequences of the previous actions.

Safety instructions for the operator



CAUTION!

Installation, assembly, start-up and maintenance may only be performed by appropriately trained personnel. The regional occupational health and safety directives must always be observed.



LEGAL NOTICE!

The responsibility as to the suitability and intended use of this device rests solely with the user. The supplier assumes no responsibility in the event of improper use by the customer. Improper installation and operation may lead to loss of warranty. In addition, the "Terms and Conditions of Sale" apply which form the basis of the purchase contract.



INFORMATION!

- *Further information can be found in the manual, on the data sheet, in special manuals, certificates and on the manufacturer's website.*
- *If you need to return the device to the manufacturer or supplier, please fill out the form contained in the manual and send it with the device. Unfortunately, the manufacturer cannot repair or inspect the device without the completed form.*

2.1 Scope of delivery



INFORMATION!

Inspect the packaging carefully for damages or signs of rough handling. Report damage to the carrier and to the local office of the manufacturer.



INFORMATION!

Do a check of the packing list to make sure that you have all the elements given in the order.



INFORMATION!

The remote version will arrive in two cartons. One carton contains the signal converter and one carton contains the flow sensor.



Figure 2-1: Scope of delivery

- ① Ordered flowmeter
- ② Product documentation
- ③ Factory calibration report
- ④ Signal cable (remote version only)



INFORMATION!

Assembly materials and tools are not part of the delivery. Use the assembly materials and tools in compliance with the applicable occupational health and safety directives.

2.2 Device description

Your measuring device is supplied ready for operation. The factory settings for the operating data have been made in accordance with your order specifications.



INFORMATION!

Product specific information and extensive product specification is available using PICK, the Product Information Center KROHNE web-tool.

PICK can be found via the service menu button on the KROHNE.com website.



The following versions are available:

- Compact version (the signal converter is installed directly on the measuring sensor)
- Remote version (electrical connection to the signal converter via field current and signal cable)



INFORMATION!

This flow sensor can be used as a remote version or as a compact version. All versions are covered by this document, although you will see the remote version in most pictures.

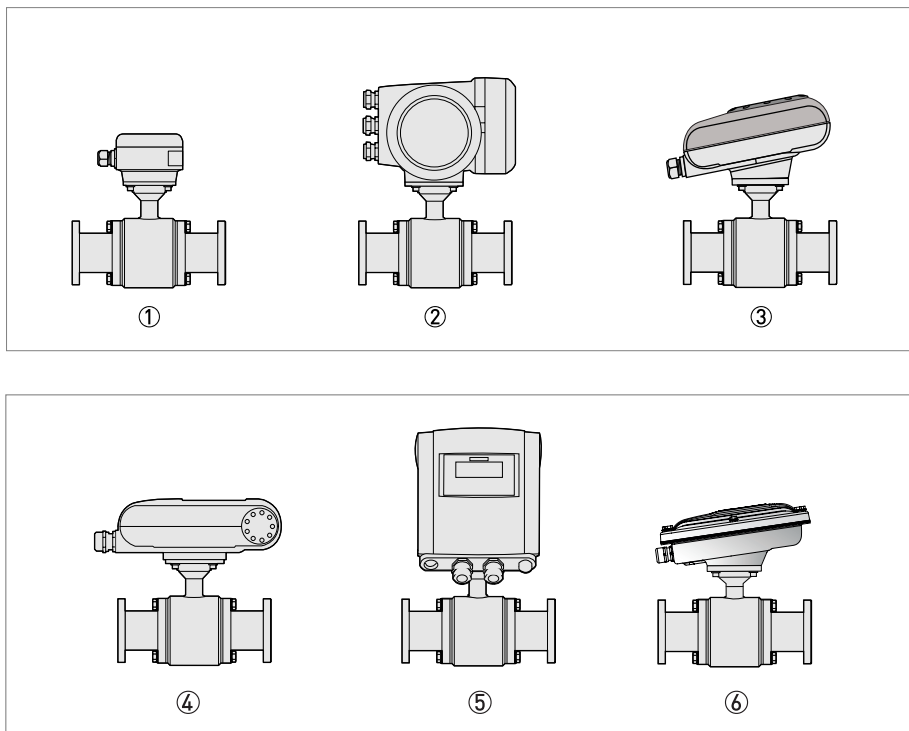

Figure 2-2: Available versions

- ① Remote version
- ② Compact version with IFC 300 signal converter
- ③ Compact version with IFC 050 (10°) signal converter
- ④ Compact version with IFC 100 (0°) signal converter
- ⑤ Compact version with IFC 100 (45°) signal converter
- ⑥ Compact version with IFC 100 stainless steel signal converter (10°)

2.3 Nameplates (examples)



INFORMATION!

Look at the device nameplate to ensure that the device is delivered according to your order. Check for the correct supply voltage printed on the nameplate.

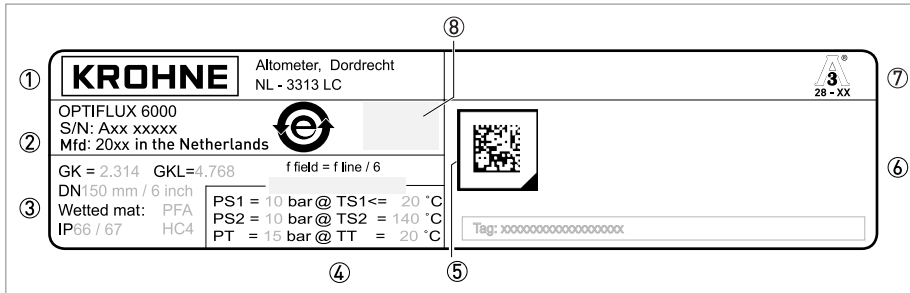

Figure 2-3: Example of a nameplate on a flow sensor

- ① Name and address of the manufacturer
- ② Type designation of the flowmeter, serial number, manufacturing date and country of origin
- ③ Calibration data, size and protection category
- ④ PED data conform applicable standard
- ⑤ Data matrix
- ⑥ Additional info and/or approvals related information
- ⑦ Product certification and/or other marking
- ⑧ Conformity mark (e.g. CE/UKCA) with number(s) of notified body/bodies and disposal logo

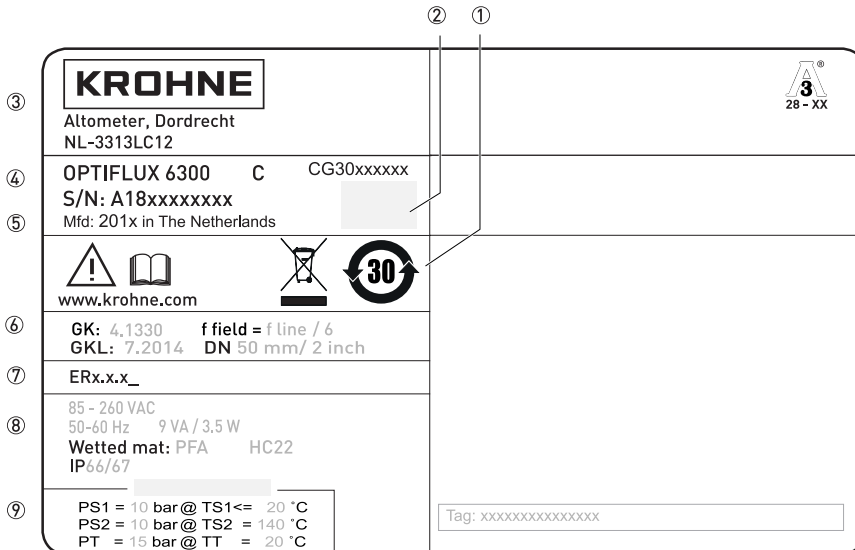

Figure 2-4: Example of a nameplate for a compact version

- ① Additional info, website and disposal logo
- ② Conformity mark (e.g. CE/UKCA) with number(s) of notified body/bodies
- ③ Name and address of manufacturer
- ④ Type designation of the flowmeter with serial / CG number
- ⑤ Manufacturing date and country of origin
- ⑥ GK/GKL values (measuring sensor constants), size (mm/inches), field frequency
- ⑦ Electronic Revision number
- ⑧ Electric values, protection category and materials of wetted parts
- ⑨ PED data conform applicable standard

2.4 Storage

- Store the device in a dry and dust-free location.
- Avoid lasting direct exposure to the sun.
- Store the device in its original packaging.
- Storage temperature: -50...+70°C / -58...+158°F

2.5 Transport

Signal converter

- No special requirements.

Compact version

- Do not lift the device by the signal converter housing.
- Do not use lifting chains.
- To transport flange devices, use lifting straps. Wrap these around both process connections.

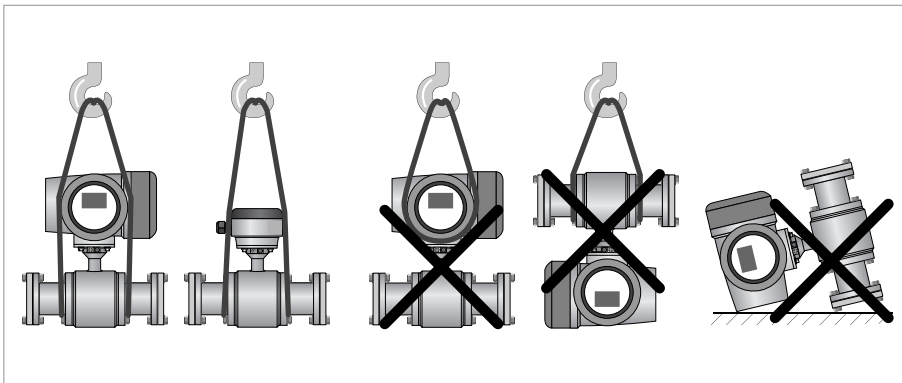

Figure 2-5: Transport

2.6 Pre-installation requirements

Make sure that you have all necessary tools available:

- Allen key (4 mm)
- Small screwdriver
- Wrench for cable glands
- Wrench for wall mounting bracket (remote version only)
- Torque wrench for installing flowmeter in pipeline

2.7 General requirements



INFORMATION!

The following precautions must be taken to ensure reliable installation.

- Make sure that there is adequate space to the sides.
- Protect the signal converter from direct sunlight and install a sun shade if necessary.
- Signal converters installed in control cabinets require adequate cooling, e.g. by fan or heat exchanger.
- Do not expose the signal converter to intense vibrations and mechanical shocks. The measuring devices are tested for a vibration/shock level as described in the chapter "Technical data" in the manual and the technical documentation.
- Avoid magnetic field! Keep at least 5 DN distance between electromagnetic flow sensors.

2.7.1 Vibration

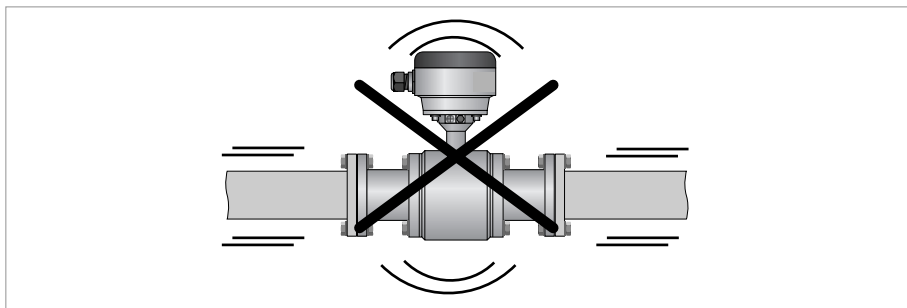

Figure 2-6: Avoid vibrations

2.7.2 Magnetic field

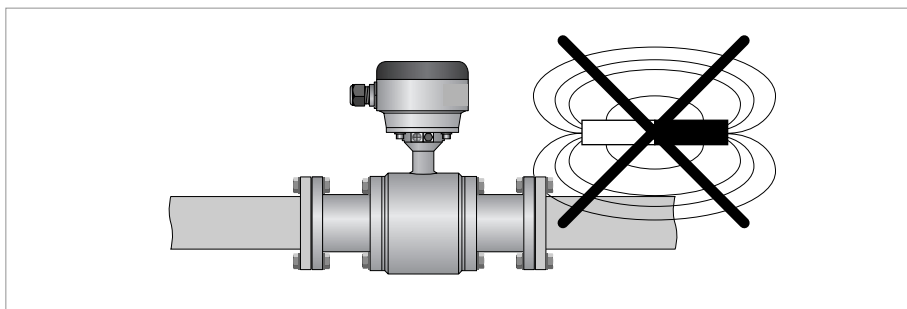

Figure 2-7: Avoid magnetic fields

2.8 Installation conditions

2.8.1 Inlet and outlet

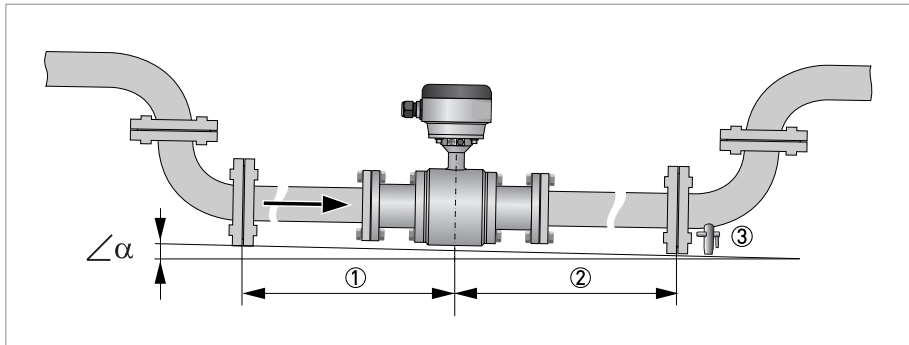

Figure 2-8: Recommended inlet and outlet

- ① Refer to chapter "Bends in 2 or 3 dimensions"
 - ② $\geq 2 \text{ DN}$
 - ③ Drain valve (to empty pipeline)
- $\angle \alpha ; > 2^\circ$

2.8.2 Bends in 2 or 3 dimensions

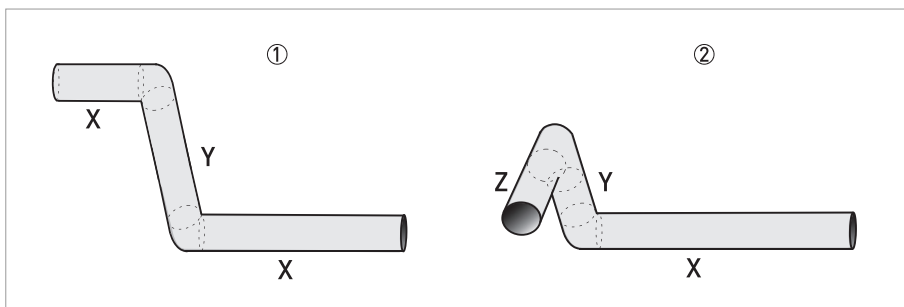

Figure 2-9: 2 and/or 3 dimensional bends upstream of the flowmeter

- ① 2 dimensions = X/Y
- ② 3 dimensions = X/Y/Z

Inlet length: using bends in 2 dimensions: $\geq 5 \text{ DN}$; when having bends in 3 dimensions: $\geq 10 \text{ DN}$



INFORMATION!

2 dimensional bends occur in a vertical **or** horizontal plane (X/Y) only, while 3 dimensional bends occur in both vertical **and** horizontal plane (X/Y/Z).

2.8.3 Bends

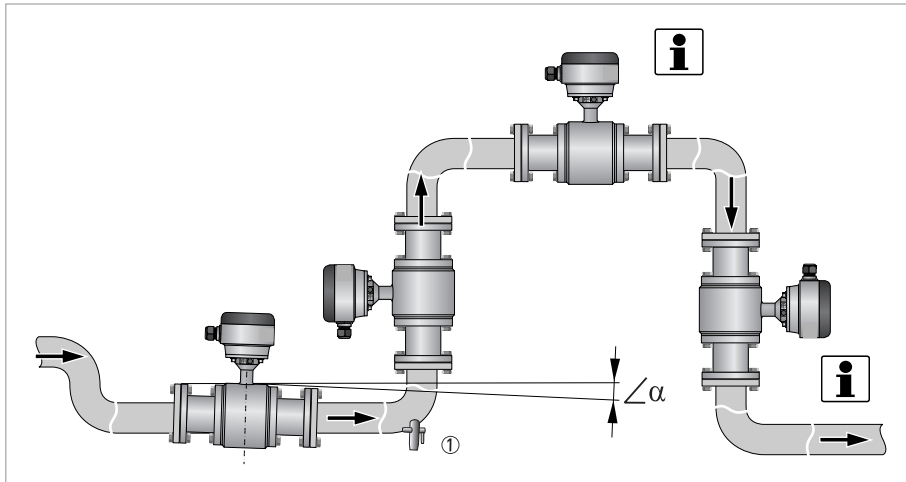

Figure 2-10: Installation in bending pipes (90°)

 $\angle \alpha ; > 2^\circ$

① Drain valve (to empty pipeline)

**INFORMATION!**

Recommended installation positions are at a lowered or ascending section of the pipeline installation. Installation at the highest point will enlarge the risk of flowmeter malfunction, because of air/gas bubbles.

Vertical installation in combination with an open surcharge has to be avoided. Vertical installation with a controlled back-pressure is possible.

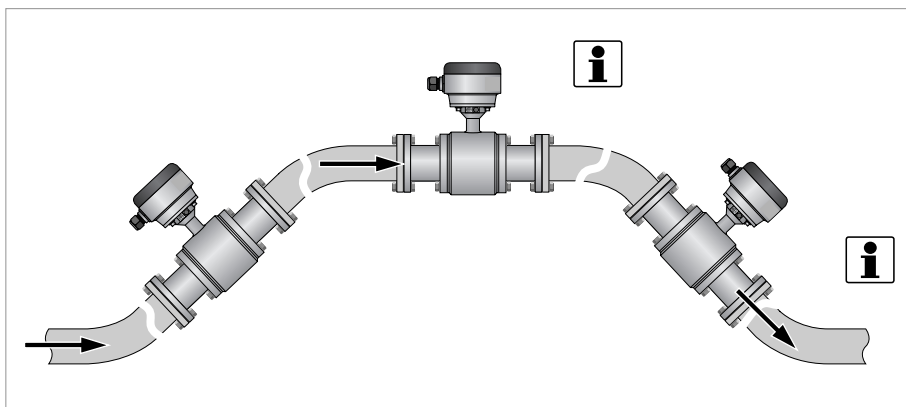

Figure 2-11: Installation in bending pipes (45°)

**INFORMATION!**

Vertical installation on a descending slope in the pipeline is only recommended when the back-pressure is controlled.

2.8.4 T-section

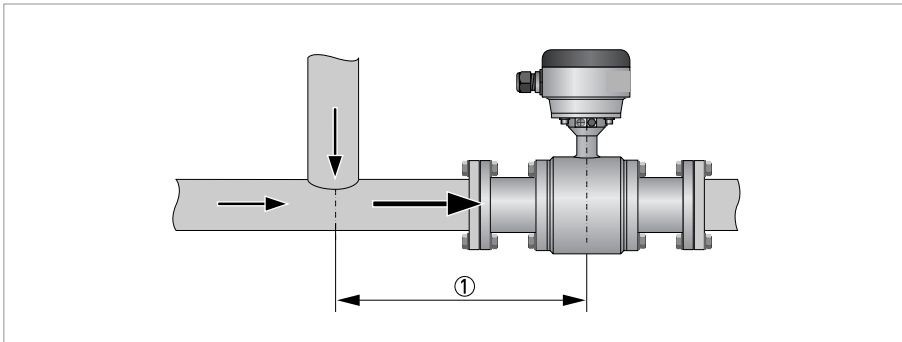

Figure 2-12: Distance behind a T-section

① ≥ 10 DN

2.8.5 Open discharge

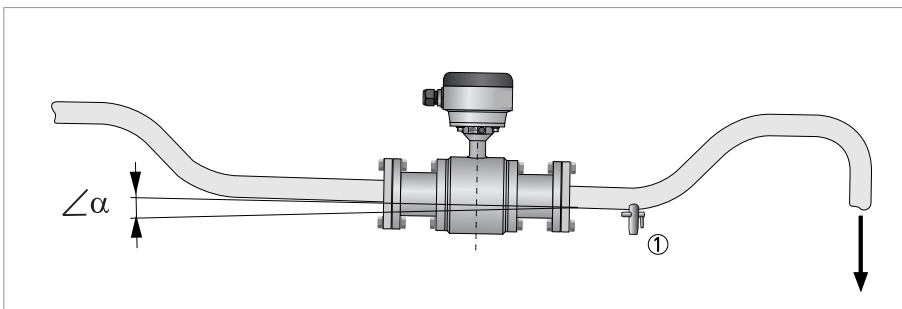

Figure 2-13: Installation in front of an open discharge

$\angle \alpha ; > 2^\circ$

① Drain valve (to empty pipeline)

2.8.6 Control valve

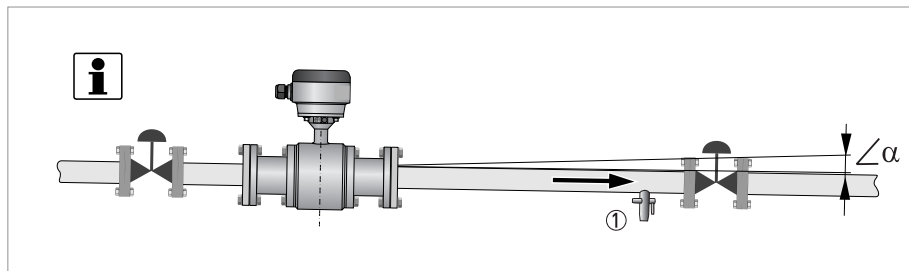

Figure 2-14: Installation in front of a control valve

 $\angle \alpha ; > 2^\circ$

① Drain valve (to empty pipeline)

**INFORMATION!**

Recommended position to install a flowmeter is upstream a control valve.

An electromagnetic flowmeter can be installed downstream of the control valve if there is no cavitation in the pipeline system (e.g. flow profile disturbances are resolved).

2.8.7 Pump

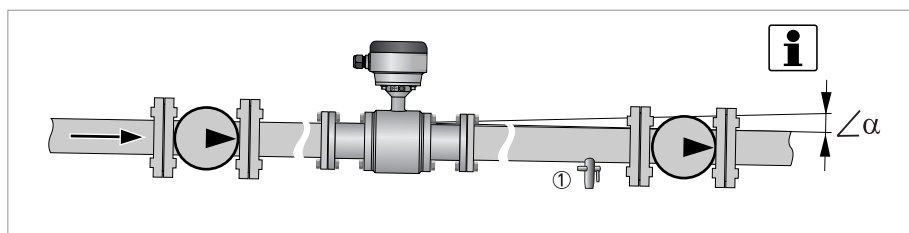

Figure 2-15: Installation behind a pump

**INFORMATION!**

Recommended position to install a flowmeter is downstream a pump (on a position where the flow disturbances of the pump are resolved).

An electromagnetic flowmeter can be installed in the suction line of a pump if there is no cavitation in the pipeline system.

2.8.8 Air venting and vacuum forces

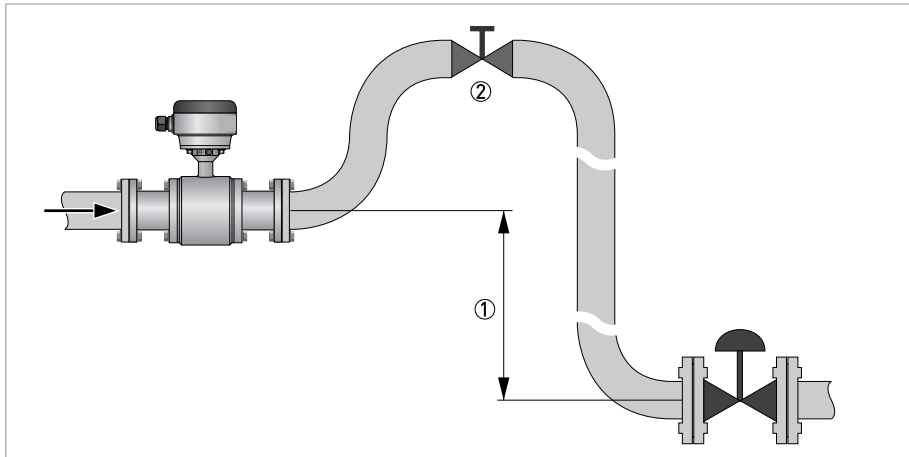

Figure 2-16: Air venting

- ① ≥ 5 m
- ② Air ventilation point

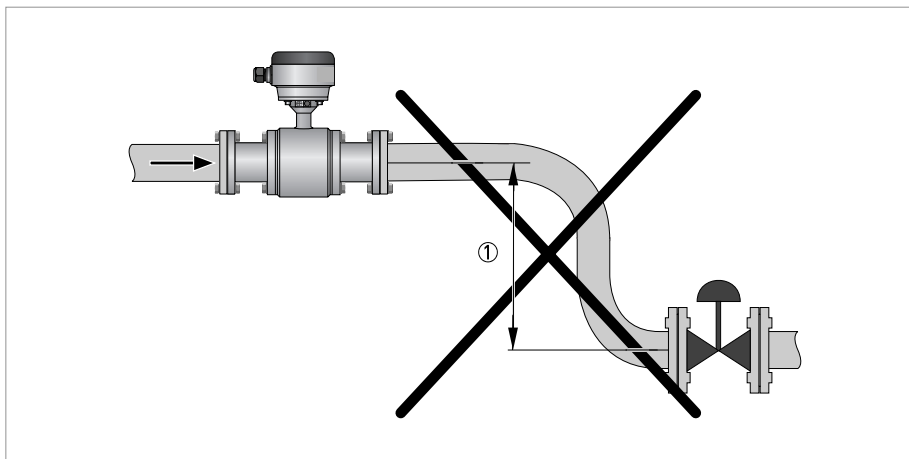

Figure 2-17: Vacuum

- ① ≥ 5 m

2.8.9 Mounting requirements for self-draining



INFORMATION!

Applicable for 3A marked installations: install flow sensor in vertical pipelines or in pipelines with a minimum slope as indicated!

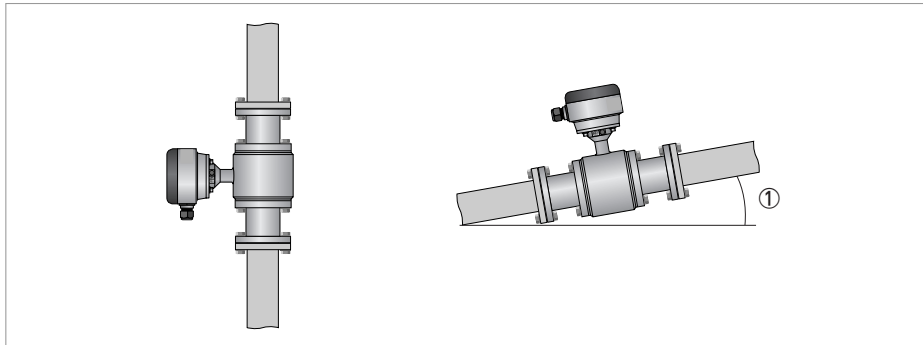

Figure 2-18: Installation note for 3A marked installations

① Minimum slope

Minimum slope

Nominal diameter	DIN EN 10357 / DIN 11850	ISO 2037	DIN 11864 2A	ISO 2852	DIN 32676	Tri Clamp
2.5...6	10°	10°	-	-	-	-
10	3°	3°	-	-	-	-
15	10°	10°	-	①	-	-
25	10°	3°	10°	3°	10°	3°
40...50	5°	3°	5°	3°	5°	3°
65...80	10°	3°	10°	3°	10°	3°
100	5°	3°	5°	3°	5°	3°
125...150	10°	3°	10°	3°	①	①

① on request

2.8.10 Flange deviation



CAUTION!

Max. permissible deviation of pipe flange faces:

$$L_{max} - L_{min} \leq 0.5 \text{ mm} / 0.02''$$

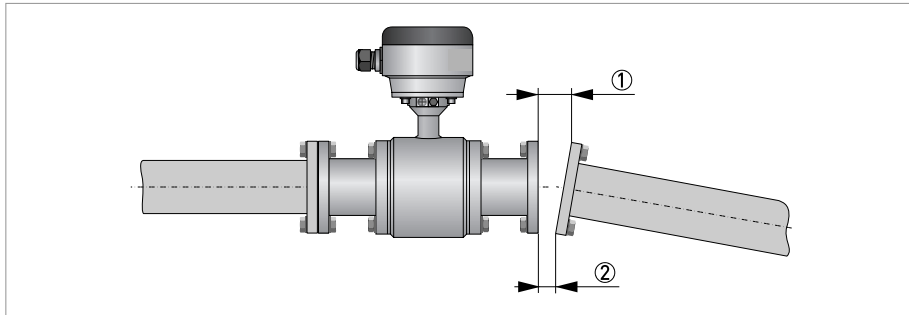

Figure 2-19: Flange deviation

- ① L_{max}
- ② L_{min}

2.8.11 Mounting position

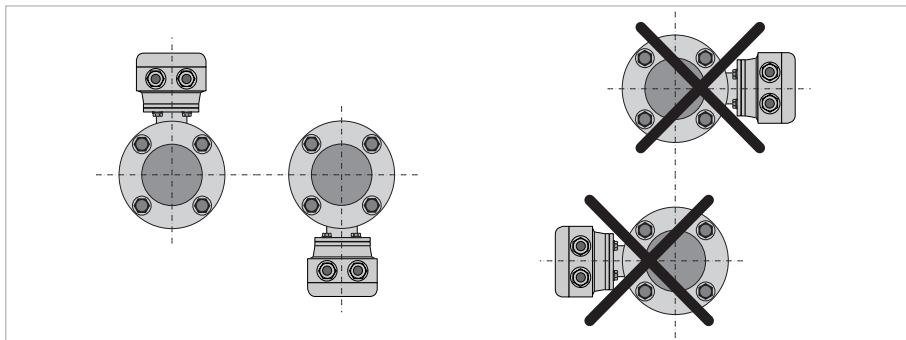

Figure 2-20: Mounting position

- Install the flow sensor with the signal converter aligned upwards or downwards.
- Install the flow sensor in line with the pipe axis.
- Pipe flange faces must be parallel to each other.

2.9 Mounting

2.9.1 Torques and pressures

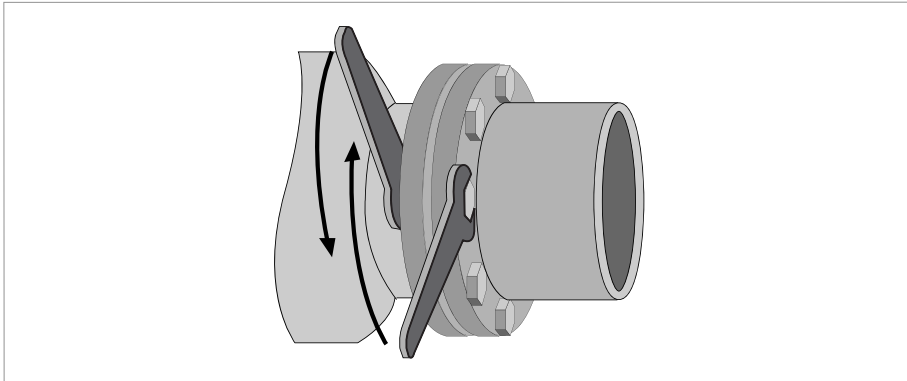

Figure 2-21: Tightening of bolts



CAUTION!

The max. allowable torque depends on the gasket material, see datasheet for detailed information. Bolts to be used from material SS, class 70-A2.



Tightening of bolts

- Always tighten the bolts uniformly and in diagonally opposite sequence.
- Do not exceed the maximum torque value.
- Step 1: Apply approx. 50% of max. torque given in table.
- Step 2: Apply approx. 80% of max. torque given in table.
- Step 3: Apply 100% of max. torque given in table.

Maximum torque for 11864-2A flange version

Nominal diameter [mm]	Pressure rating	Bolts	Max. torque [Nm]
25	PN 40	4x M6	7
40	PN 40	4x M8	16
50	PN 25	4x M8	16
80	PN 25	6x M8	16
100	PN 25	6x M8	16
125	PN 10	6x M10	32
150	PN 10	6x M10	32



INFORMATION!

Maximum torque for sizes smaller than DN25: 6 Nm

2.9.2 EHEDG applications

Couplings and connections

Correct pipe couplings and process connections (including special gaskets/seals) must be applied, according to the most recent version of the "EHEDG applications Position Paper" (for details; refer to the EHEDG website). The applied seals consist of material EPDM, must be approved for food contact and have the applicable FDA approval.

Weld-on adapters

Weld-on versions of the adapters are available. If welded adapters are used these must be TIG welded and the food contact surfaces must have a surface roughness of $Ra \leq 0.8 \mu\text{m}$. Instructions for welding are given in EHEDG documents 9 and 35 are available on the EHEDG website.

Drain-ability

The sensor does not contain any hollow parts and is easily drainable by applying an angle or a vertical installation position. EHEDG applications require a minimum slope of 3° or higher (refer to *Installation conditions* on page 9).

Installation and Cleanability

Flowmeter process connections must be mounted in such a way that the leak detection holes in the application are at the lowest point. The sensor is developed for cleaning-in-place (CIP) and cleaning is done together with the cleaning of the pipeline without dismantling the sensor (class I equipment). During CIP-cleaning, the maximum allowable sensor pressure and temperature must be followed (refer to *Temperatures* on page 18).

2.9.3 Installation of weld-on versions

For mounting flow sensors with weld-on connections, please follow the procedure as follows:



- Mount the flow sensor completely in the pipeline and spot the weld-on connections to the pipe. This is necessary to align the mounting bores of the flange.
- Remove the flow sensor body and the gaskets from the adapters by loosen the screws.
- Weld the adapters completely to the pipe.
- When the pipe is cold again, reinstall the gasket and mount the flow sensor.

2.9.4 Cleaning



CAUTION!

In principle, no special maintenance is needed. However, make sure that the used cleaning product doesn't affect the outer surface and the gaskets.

2.9.5 Temperatures

**CAUTION!**

Protect the device from direct sunlight.

Ambient temperature

	°C		°F	
	min.	max.	min.	max.
Separate flow sensor Compact version with; IFC 050 , IFC 100 and IFC 300	-40	65	-40	149
Separate flow sensor Compact version with; IFC 100 stainless steel	-40	60	-40	140

Maximum process temperature

Type of connection	Separate flow sensor		Compact + IFC 050 / IFC 100		Compact + IFC 300	
	°C	°F	°C	°F	°C	°F
Aseptic weld on for pipes to DIN 11850	140	284	120 ①	248 ②	140	284
Aseptic weld on for pipes to ISO 2037	140	284	120 ①	248 ②	140	284
Dairy screw to DIN 11851 ③	140	284	120 ①	248 ②	140	284
Screwed to SMS 1146 ③	140	284	120 ①	248 ②	140	284
Flanges to DIN 11864-2A	140	284	120 ①	248 ②	140	284
Clamp joint to ISO 2852	120	248	120	248	120	248
Clamp joint to DIN 32676	140	284	120 ①	248 ②	140	284
Clamp joint to Tri Clamp	120	248	120	248	120	248

① 140°C if ambient temperature ≤ 40°C

② 284°F if ambient temperature ≤ 104°F

③ Without 3A mark

3.1 Safety instructions

**DANGER!**

All work on the electrical connections may only be carried out with the power disconnected.
Take note of the voltage data on the nameplate!

**DANGER!**

Observe the national regulations for electrical installations!

**WARNING!**

Observe without fail the local occupational health and safety regulations.
Any work done on the electrical components of the measuring device may only be carried out by properly trained specialists.

**INFORMATION!**

Look at the device nameplate to ensure that the device is delivered according to your order.
Check for the correct supply voltage printed on the nameplate.

3.2 Grounding

**DANGER!**

The device must be grounded in accordance with regulations in order to protect personnel against electric shocks.

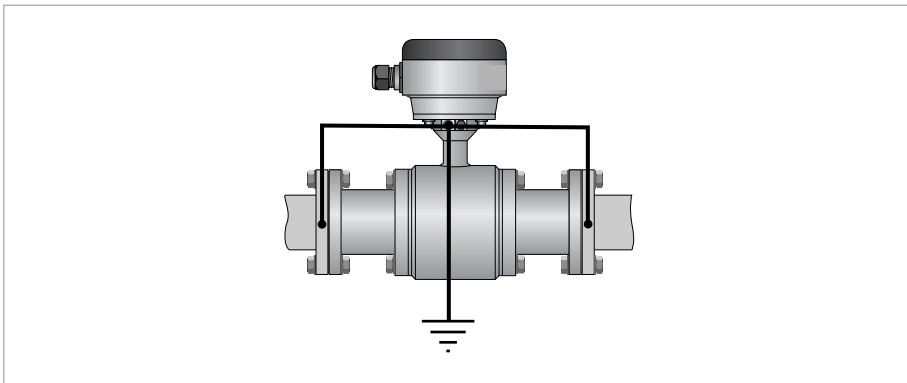

Figure 3-1: Grounding

3.3 Virtual reference for IFC 300 (C, W and F version)

Benefits of virtual reference:

- Grounding rings or grounding electrodes can be omitted.
- Safety increases by reducing the number of potential leakage points.
- The installation of the flowmeters is much easier.

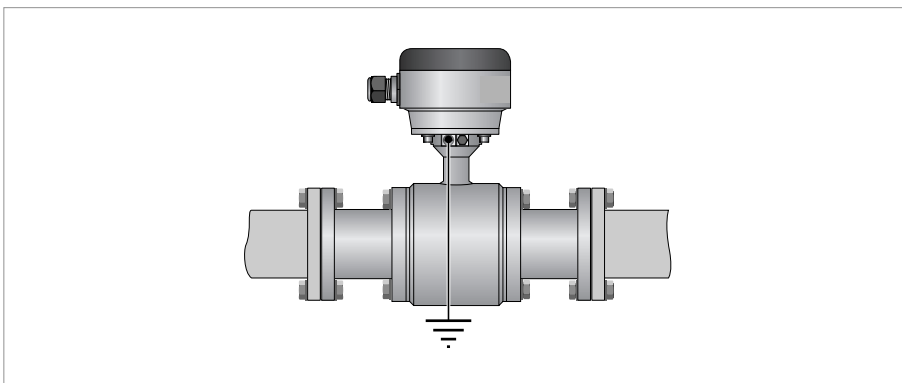

Figure 3-2: Virtual reference

Minimum requirements:

- Size: \geq DN10 / 3/8"
- Electrical conductivity: \geq 200 μ S/cm
- Electrode cable: max. 50 m / 164 ft, type DS

3.4 Connection diagrams

**INFORMATION!**

For the connection diagrams refer to the documentation of the applicable signal converter.

4.1 Dimensions and weights

DIN EN 10357/ DIN 11850 (row 2 or DIN 11866 row A)

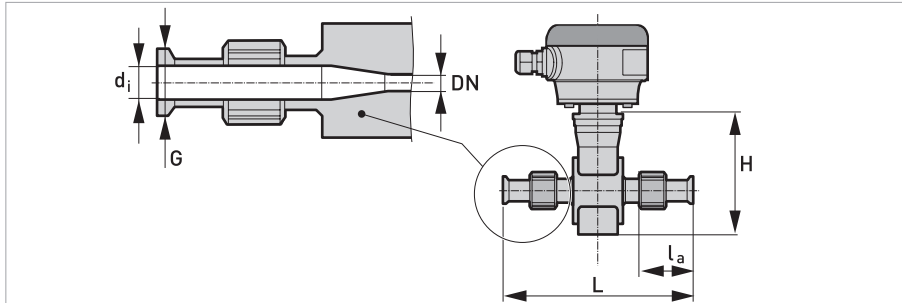

DN2.5...10 screwed adapter with DN10 process connections / DN15 screwed adapter

Nominal size		Dimensions [mm]						Approx. weight
		Adapter			Flowmeter			
DN	PN	d_i	G	l_a	L	H	W	[kg]
2.5...10	40	10	13	32	180	120	44	1.5
15	40	16	19	32	180	120	44	1.5

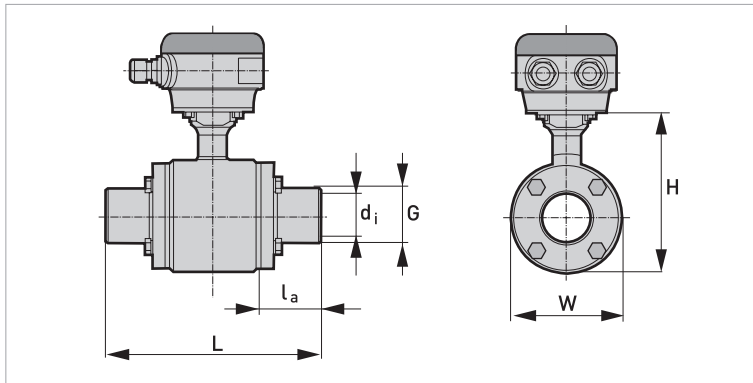

DN25...150 bolted adapter

Nominal size		Dimensions [mm]						Approx. weight
		Adapter			Flowmeter			
DN	PN	d_i	G	l_a	L	H	W	[kg]
25	40	26	29	20.6	132.6	128	89	3
40	40	38	41	61.3	220	153	114	5.3
50	25	50	53	61.3	220	153	114	6.8
65	25	66	70	41.8	220	180	141	10.9
80	25	81	85	66.8	280	191	152	11.2
100	16	100	104	59.3	280	242	203	18.4
125	10	125	129	66.3	319	258	219	29.5
150	10	150	154	64.3	325	293	254	44.3

DIN 11851

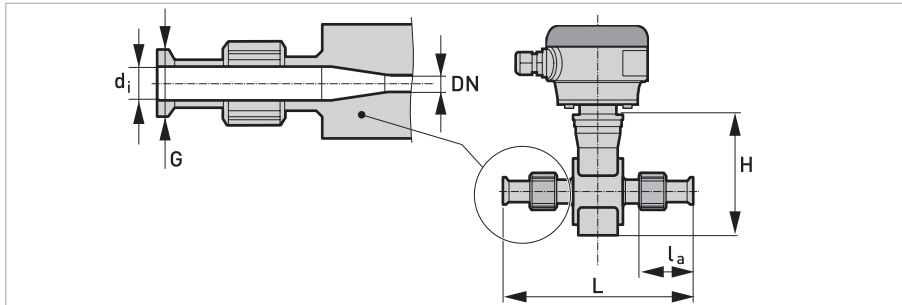

DN2.5...10 screwed adapter with DN10 process connections / DN15 screwed adapter

Nominal size		Dimensions [mm]						Approx. weight [kg]
		Adapter			Flowmeter			
DN	PN	d _i	G	l _a	L	H	W	
2.5...10	40	10	Rd 28 x 1/8"	53.1	214	142	44	1.5
15	40	16	Rd 34 x 1/8"	53.1	214	142	44	1.5

DIN 11851

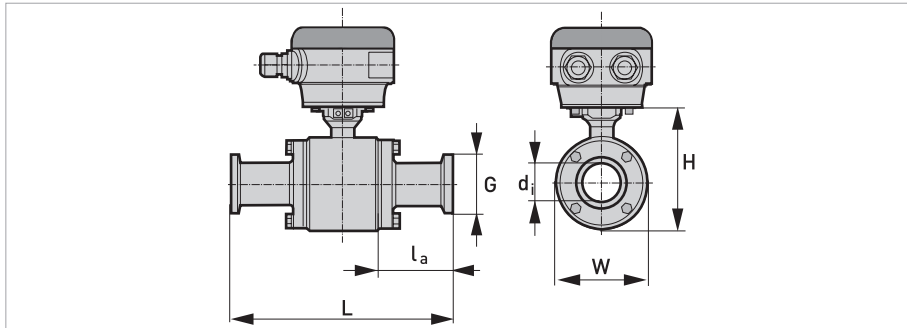

DN25...150 bolted adapter

Nominal size		Dimensions [mm]						Approx. weight
		Adapter			Flowmeter			
DN	PN	di	G	la	L	H	W	[kg]
25	40	26	Rd 52 x 1/6"	49.3	190	128	89	3.2
40	40	38	Rd 65 x 1/6"	91.3	280	153	114	5.5
50	25	50	Rd 78 x 1/6"	93.3	284	153	114	5.3
65	25	66	Rd 95 x 1/6"	77.8	292	180	141	10
80	25	81	Rd 110 x 1/4"	107.8	362	191	152	12.5
100	16	100	Rd 130 x 1/4"	109.3	380	242	203	21.8
125	10	On request						
150	10	On request						

DIN 11864-2A

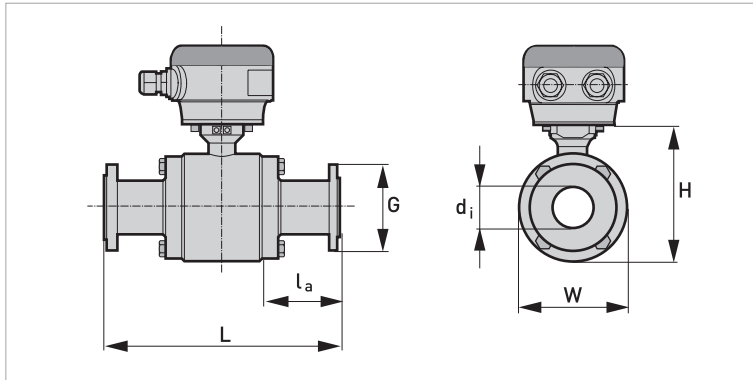

DN25...150 bolted adapter

Nominal size		Dimensions [mm]						Approx. weight [kg]
		Adapter			Flowmeter			
DN	PN	d _i	G	l _a	L	H	W	
25	40	26	70	45.8	183	128	89	4.4
40	25	38	82	83.3	264	153	114	7.5
50	25	50	94	83.3	264	153	114	9
65	25	66	113	63.8	264	180	141	14.5
80	25	81	133	122.8	392	191	152	18.6
100	16	100	159	115.3	392	242	203	28.2
125	10	125	183	121	429	259	219	35
150	10	150	213	127	450	294	254	52

DIN 32676

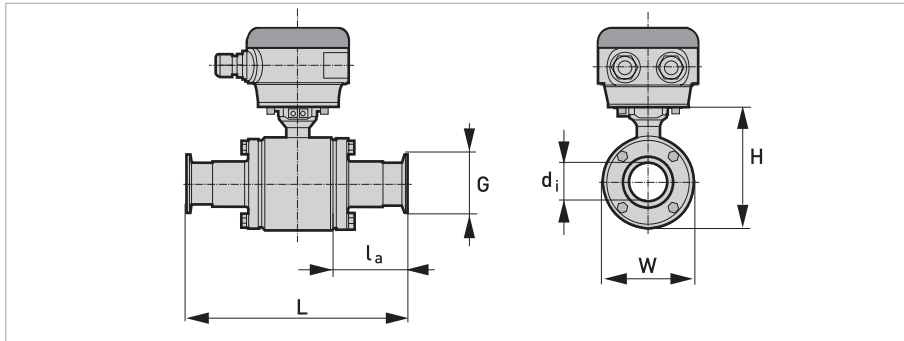

DN25...150 bolted adapter

Nominal size		Dimensions [mm]						Approx. weight
		Adapter			Flowmeter			
DN	PN	d_i	G	l_a	L	H	W	[kg]
25	16	26	50.5	41.8	175	128	89	3.2
40	16	38	50.5	80.8	259	153	114	5.5
50	16	50	64	80.8	259	153	114	5.3
65	16	66	91	67.8	272	180	141	10
80	16	81	106	92.8	332	191	152	12.5
100	16	100	119	85.3	332	242	203	21.8
125	16	125	155	90	366	259	219	30
150	16	150	213	127	450	294	254	45

ISO 2037

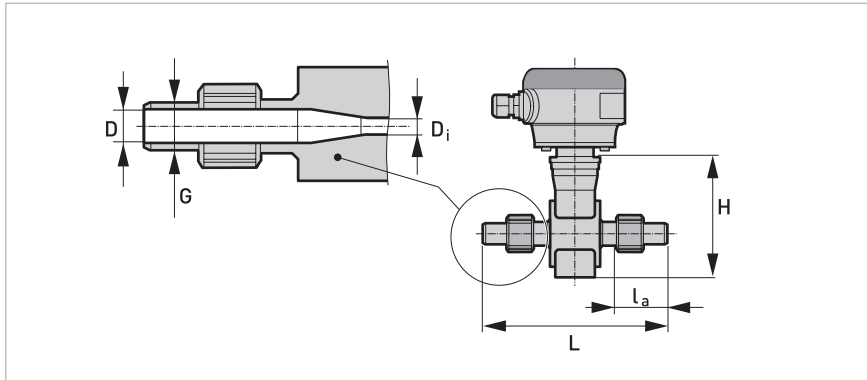

DN2.5...10 screwed adapter with DN10 process connections / DN17.2 screwed adapter

Nominal size		Dimensions [mm]						Approx. weights
		Adapter			Flowmeter			
DN	PN	d_i	G	l_a	L	H	W	[kg]
2.5...12	40	10	15	32	180	142	44	1.5
17.2	40	16	21	32	180	142	44	1.5

ISO 2037

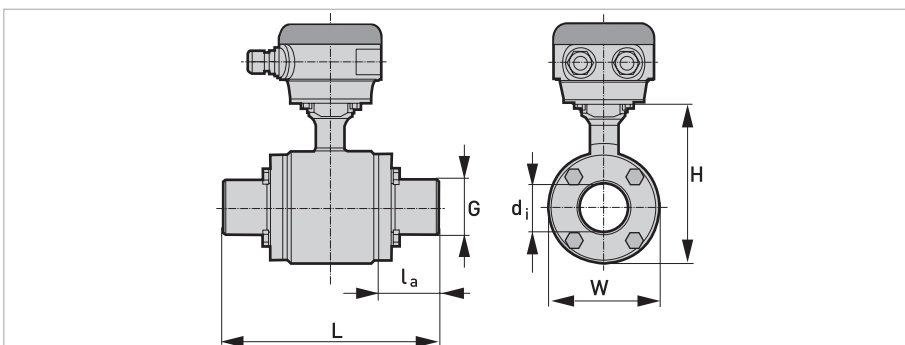

DN25...150 bolted adapter

Nominal size		Dimensions [mm]						Approx. weights
		Adapter			Flowmeter			
DN	PN	d _i	G	l _a	L	H	W	[kg]
25	40	22.6	31	20.6	132.6	128	89	3
38	40	38	43	61.3	220	153	114	5.3
51	25	49	55	61.3	220	153	114	5
63.5	25	60.3	71	41.8	220	180	141	9
76.1	25	72.9	86	66.8	280	191	152	10.8
101.6	16	97.6	105	59.3	280	242	203	18.4
114.3	10	110.3	130	66.3	319	258	219	29.5
139.7	10	135.7	156	64.3	325	293	254	44.3

ISO 2852

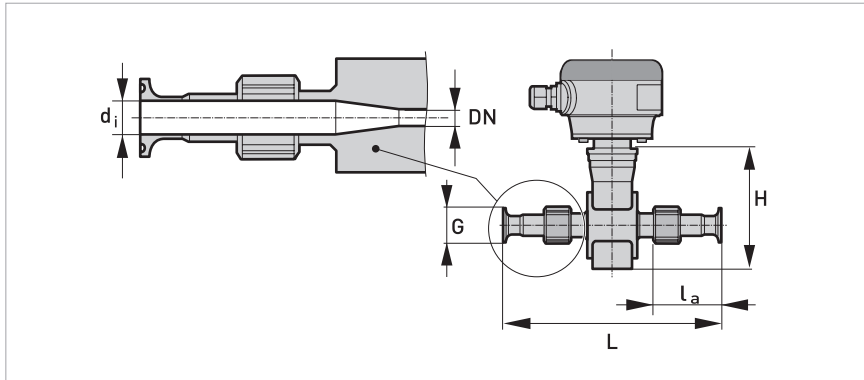

DN2.5...10 screwed adapter with DN10 process connections / DN17.2 screwed adapter

Nominal size			Dimensions [mm]						Approx. weight
			Adapter			Flowmeter			
DN	[Inch]	PN	d_i	G	l_a	L	H	W	[kg]
2.5...10	1/10"...3/8"	16	10	34	51.6	219	142	44	1.8
17.2	1/2"	16	16	34	51.6	219	142	44	1.8

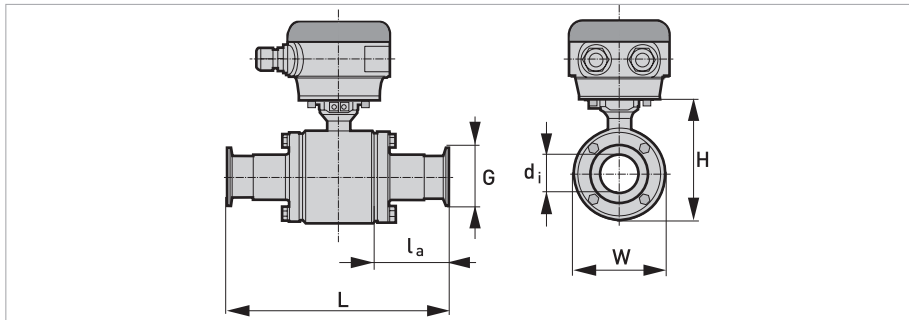

DN25...150 bolted adapter

Nominal size			Dimensions [mm]						Approx. weight [kg]
			Adapter			Flowmeter			
DN	[Inch]	PN	d_i	G	l_a	L	H	W	
25	1"	16	22.6	50.5	41.8	175	128	89	3.3
38	1.5"	16	35.6	50.5	87.8	273	153	114	5.4
50	2"	16	48.6	64	87.8	273	153	114	5.2
63.5	2.5"	10	60.3	77.5	68.3	273	180	141	9.5
76.1	3"	10	72.9	91	93.3	333	191	152	11.2
101.6	4"	8	97.6	119	85.8	333	242	203	19.1
114.3	5"	5	110.3	211	90	366	259	219	30
139.7	6"	5	135.7	246	90	376	294	254	45

Tri Clamp

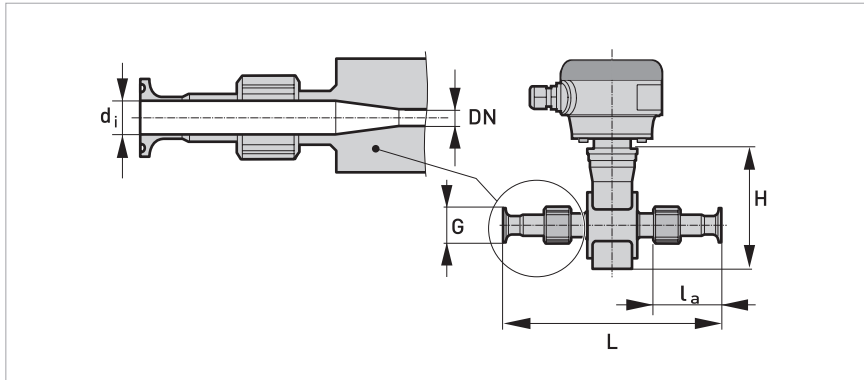

DN1/10...1/2" screwed adapter

Nominal size		Dimensions [inch]						Approx. weight
		Adapter			Flowmeter			
DN	PN	d_i	G	l_a	L	H	W	[kg]
1/10"...3/8"	20	0.37	0.98	1.97	8.5	5.59	1.73	1.5
1/2"	20	0.62	0.98	1.97	8.5	5.59	1.73	1.5

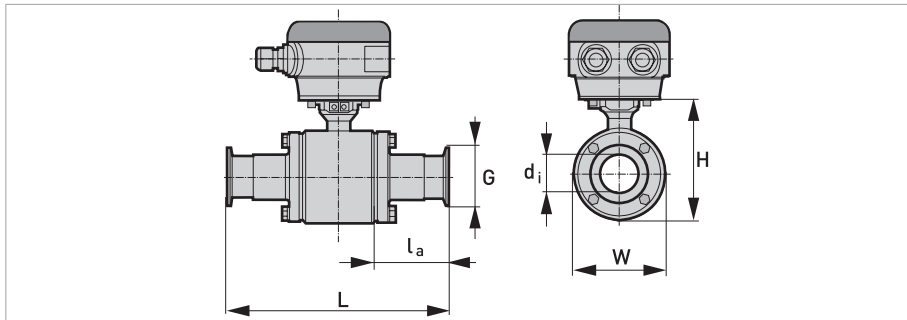

DN1...6" bolted adapter

Nominal size		Dimensions [inch]						Approx. weight
		Adapter			Flowmeter			
DN	PN	d_i	G	l_a	L	H	W	[kg]
1"	20	0.85	1.98	1.02	5.64	5.04	3.5	3.2
1½"	20	1.35	1.98	3.46	10.75	6.02	4.49	5.5
2"	20	1.85	2.52	3.46	10.75	6.02	4.49	5.3
2½"	20	2.35	3.05	2.69	10.75	7.09	5.55	10
3"	20	2.85	3.54	3.68	13.11	7.52	5.98	12.5
4"	12	3.83	4.68	3.38	13.11	9.53	7.99	21.8
5"	-	4.78	5.69	3.54	14.43	10.20	8.62	30
6"	-	5.78	6.57	3.62	14.80	11.57	10.00	45

SMS 1146 Adapter

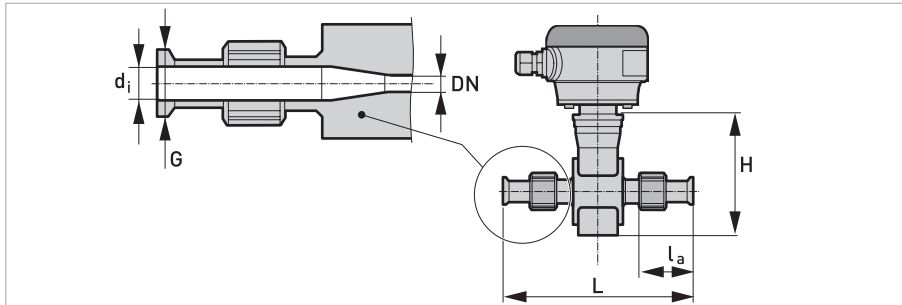

DN2.5...10 screwed adapter with DN10 process connections / DN15 screwed adapter

Nominal size		Dimensions [mm]						Approx. weight [kg]
		Adapter			Flowmeter			
DN	PN	d_i	G	l_a	L	H	W	
2.5	39	10	Rd 40-6	53	226	128	44	2
4	39	10	Rd 40-6	53	226	128	44	2
6	39	10	Rd 40-6	53	226	128	44	2
10	6	10	Rd 40-6	53	226	128	44	2
15	6	10	Rd 40-6	53	226	128	44	2

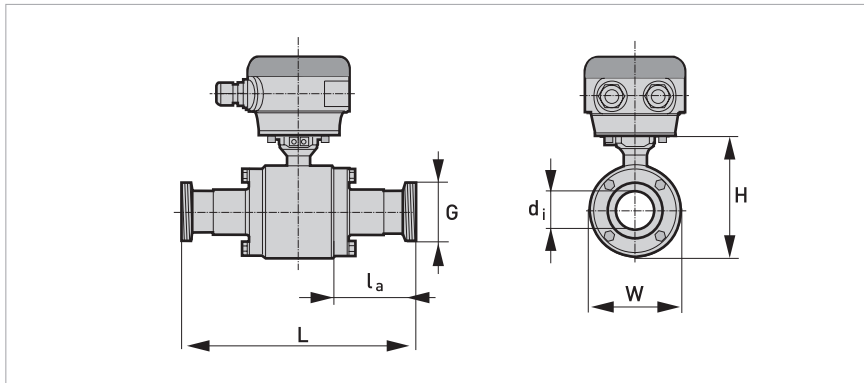

DN25...100 bolted adapter

Nominal size		Dimensions [mm]						Approx. weight
		Adapter			Flowmeter			
DN	PN	d _i	G	l _a	L	H	W	[kg]
25	6	22.6	Rd 40-6	28.1	147.6	128	89	3.2
38	6	35.5	Rd 60-6	54	262	153	114	5.7
51	6	48.6	Rd 70-6	84.3	266	153	114	5.4
63.5	6	60.3	Rd 85-6	69.8	276	180	141	9.9
76	6	72.9	Rd 98-6	99.8	346	191	152	12.1
100	6	97.6	Rd 132-6	44	336	242	203	21.9



KROHNE – Products, Solutions and Services

- Process instrumentation for flow, level, temperature, pressure measurement and process analytics
- Flow metering, monitoring, wireless and remote metering solutions
- Engineering, commissioning, calibration, maintenance and training services

Head Office KROHNE Messtechnik GmbH
Ludwig-Krohne-Str. 5
47058 Duisburg (Germany)
Tel.: +49 203 301 0
Fax: +49 203 301 10389
info@krohne.de

The current list of all KROHNE contacts and addresses can be found at:
www.krohne.com

KROHNE