



OPTIBAR PM 3050 Handbook

Compact pressure transmitter with metallic diaphragm

4...20 mA / HART®

ER.REV. 1.0._

All rights reserved. It is prohibited to reproduce this documentation, or any part thereof, without the prior written authorisation of KROHNE Messtechnik GmbH.

Subject to change without notice.

Copyright 2019 by
KROHNE Messtechnik GmbH - Ludwig-Krohne-Str. 5 - 47058 Duisburg (Germany)

1	Safety instructions	5
1.1	Software history	5
1.2	Intended use	6
1.3	Technical limits	7
1.4	Permissible products	7
1.5	Certification	7
1.6	Safety instructions from the manufacturer	8
1.6.1	Copyright and data protection	8
1.6.2	Disclaimer.....	8
1.6.3	Product liability and warranty	9
1.6.4	Information concerning the documentation.....	9
1.6.5	Warnings and symbols used.....	10
1.7	Safety instructions for the operator.....	10
2	Device description	11
2.1	Scope of delivery.....	11
2.2	Description of device	12
2.2.1	Device design	13
2.2.2	Process connection variants.....	14
2.3	Nameplates	15
3	Installation	16
3.1	General notes on installation	16
3.2	Storage	16
3.3	Transport	16
3.4	Installation specifications	16
3.5	Mounting	17
3.5.1	Sealing and screwing-in	17
3.5.2	Humidity	17
3.5.3	Pressure connection via impulse line	18
3.5.4	Opening the device, installing and dismantling the graphic display	18
3.6	Ventilating the pressure sensor.....	19
4	Electrical connections	20
4.1	Safety instructions.....	20
4.2	Notes for electrical cables	20
4.2.1	Requirements for signal cables provided by the customer	21
4.2.2	Laying electrical cables correctly.....	21
4.2.3	Connection to the power supply	22
4.2.4	Connection with M12 quick disconnect	22
4.3	Electrical connection	22
4.3.1	Cable preparation	22
4.3.2	Connection in the terminal compartment.....	23
4.4	Grounding the measuring device	23
4.5	Description of the current output.....	24

5 Operation	25
5.1 Start-up	25
5.2 Factory settings on delivery	25
5.3 General operation	26
5.4 Operation without display and adjustment module	26
5.4.1 Sensor mounting correction (offset)	26
5.4.2 Zero point and lower range limit (4 mA)	27
5.4.3 Span and upper range limit (20 mA)	27
5.4.4 Factory reset	28
5.5 Operation with display and adjustment module	28
5.5.1 Display and operating elements	28
5.5.2 Structure of the operating menu	30
5.5.3 Description of the function	31
6 Service	32
6.1 Replacing the pressure sensor, the electronics and the display	32
6.2 Spare parts availability	32
6.3 Availability of services	33
6.4 Repairs	33
6.5 Returning the device to the manufacturer	33
6.5.1 General information	33
6.5.2 Form (for copying) to accompany a returned device	34
6.6 Disposal	34
7 Technical data	35
7.1 Measuring principle	35
7.2 Technical data	37
7.3 Pressure ranges	42
7.4 Dimensions and weights	43
7.5 Dynamic output behaviour	60
8 Description of HART interface	61
8.1 General description	61
8.2 Software history	61
8.3 Connection variants	62
8.4 Inputs/outputs and HART [®] dynamic variables and device variables	62
8.5 HART [®] commands	63
9 Notes	65

1.1 Software history



INFORMATION!

In the table below, "x" is a placeholder for possible multi-digit alphanumeric combinations, depending on the available version.

Changes and effect on compatibility

1	Downwards compatible changes and fault repair with no effect on operation (e.g. spelling mistakes on display)	
2- _	Downwards compatible hardware and/or software change of interfaces:	
	H	HART®
	P	PROFIBUS
	F	Foundation Fieldbus
	M	Modbus
	X	all interfaces
3- _	Downwards compatible hardware and/or software change of inputs and outputs:	
	I	Current Output
	F, P	Frequency / pulse output
	S	Status Output
	C	Control input
	CI	Current input
	X	all inputs and outputs
4	Downwards compatible changes with new functions	
5	Incompatible changes, i.e. electronic equipment must be changed.	

Release date	SW version	HW version	Changes and compatibility	Documentation
2017-12-01	1.0.X_	1.0.X_	-	MA OPTIBAR PM 3050 R01
2019-01-11	1.01.X_	1.00.X_	1, 2-H, 3-I, 4	MA OPTIBAR PM 3050 R02

1.2 Intended use

**CAUTION!**

Responsibility for the use of the measuring devices with regard to suitability, intended use and corrosion resistance of the used materials against the measured fluid lies solely with the operator.

**INFORMATION!**

The manufacturer is not liable for any damage resulting from improper use or use for other than the intended purpose.

The pressure transmitter series **OPTIBAR** is designed and constructed to measure the absolute and gauge pressure of gases, vapours and liquids. The available measuring ranges and permitted maximum working pressures for each unit are indicated on the nameplate and described in the "Technical data" section. To observe the intended use, adhere to the following points:

- Observe the instructions in this document.
- Comply with the technical specifications (for details refer to *Technical limits* on page 7).
- Observe the permissible products (for details refer to *Permissible products* on page 7).
- Only qualified personnel may install and operate the device.
- Observe the generally accepted standards of good practice.

**CAUTION!**

- *Any modification to the device, including drilling, sawing, trimming, welding and soldering of parts, or partially painting over or coating, is prohibited.*
- *Neither is it permitted to use the device as a climbing aid e.g. for installation purposes, as a holder for cables, pipes or other loads.*
- *The mounting or installation of parts is only permitted as described in this document, or insofar as it has been authorised by the manufacturer or a certified service partner.*

**DANGER!**

For devices used in hazardous areas, additional safety notes apply; please refer to the Ex documentation.

1.3 Technical limits

The device was constructed solely for use within the technical limits indicated on the nameplate and in the technical data. Applications outside of these limits are not permitted and could lead to significant risk of accident. For this reason, observe the following limits:

- Do not exceed the maximum working pressure (MWP).
- Do not exceed the indicated permissible operating temperature range.
- The permissible ambient temperatures given may not be exceeded or undershot.
- Check the materials used for the wetted parts (e.g. gasket, process connection, separating diaphragm etc.) for suitability as regards process compatibility.

1.4 Permissible products

The device is designed to measure the pressure of vaporous, gaseous and liquid media. Device variants featuring recessed diaphragms are not suitable for the measurement of products containing solids or viscous and paste-like products. Prior to using any corrosive or abrasive products, the operator must check the resistance of all parts in contact with the product.

1.5 Certification

CE marking

The device fulfils the statutory requirements of the following EC directives:

- EMC Directive 2004/108/EC
- EMC specification acc. to EN 61326-1:2013

The manufacturer certifies successful testing of the product by applying the CE mark.

Pressure Equipment Directive PED

Devices with a permissible pressure $PS \leq 200$ bar (20 MPa) comply with 2014/68/EU Article 4 Section (3) and are not subject to a conformity assessment. These devices were designed and manufactured in accordance with sound engineering practice (SEP).

The CE marking on the device does not apply to the pressure equipment directive.



DANGER!

For devices used in hazardous areas, additional safety notes apply; please refer to the Ex documentation.

1.6 Safety instructions from the manufacturer

1.6.1 Copyright and data protection

The contents of this document have been created with great care. Nevertheless, we provide no guarantee that the contents are correct, complete or up-to-date.

The contents and works in this document are subject to copyright. Contributions from third parties are identified as such. Reproduction, processing, dissemination and any type of use beyond what is permitted under copyright requires written authorisation from the respective author and/or the manufacturer.

The manufacturer tries always to observe the copyrights of others, and to draw on works created in-house or works in the public domain.

The collection of personal data (such as names, street addresses or e-mail addresses) in the manufacturer's documents is always on a voluntary basis whenever possible. Whenever feasible, it is always possible to make use of the offerings and services without providing any personal data.

We draw your attention to the fact that data transmission over the Internet (e.g. when communicating by e-mail) may involve gaps in security. It is not possible to protect such data completely against access by third parties.

We hereby expressly prohibit the use of the contact data published as part of our duty to publish an imprint for the purpose of sending us any advertising or informational materials that we have not expressly requested.

1.6.2 Disclaimer

The manufacturer will not be liable for any damage of any kind by using its product, including, but not limited to direct, indirect or incidental and consequential damages.

This disclaimer does not apply in case the manufacturer has acted on purpose or with gross negligence. In the event any applicable law does not allow such limitations on implied warranties or the exclusion of limitation of certain damages, you may, if such law applies to you, not be subject to some or all of the above disclaimer, exclusions or limitations.

Any product purchased from the manufacturer is warranted in accordance with the relevant product documentation and our Terms and Conditions of Sale.

The manufacturer reserves the right to alter the content of its documents, including this disclaimer in any way, at any time, for any reason, without prior notification, and will not be liable in any way for possible consequences of such changes.

1.6.3 Product liability and warranty

The operator shall bear responsibility for the suitability of the device for the specific purpose. The manufacturer accepts no liability for the consequences of misuse by the operator. Improper installation or operation of the devices (systems) will cause the warranty to be void. The respective "Standard Terms and Conditions" which form the basis for the sales contract shall also apply.

1.6.4 Information concerning the documentation

To prevent any injury to the user or damage to the device it is essential that you read the information in this document and observe applicable national standards, safety requirements and accident prevention regulations.

If this document is not in your native language and if you have any problems understanding the text, we advise you to contact your local office for assistance. The manufacturer can not accept responsibility for any damage or injury caused by misunderstanding of the information in this document.

This document is provided to help you establish operating conditions, which will permit safe and efficient use of this device. Special considerations and precautions are also described in the document, which appear in the form of icons as shown below.

1.6.5 Warnings and symbols used

Safety warnings are indicated by the following symbols.



DANGER!

This warning refers to the immediate danger when working with electricity.



DANGER!

This warning refers to the immediate danger of burns caused by heat or hot surfaces.



DANGER!

This warning refers to the immediate danger when using this device in a hazardous atmosphere.



DANGER!

These warnings must be observed without fail. Even partial disregard of this warning can lead to serious health problems and even death. There is also the risk of seriously damaging the device or parts of the operator's plant.



WARNING!

Disregarding this safety warning, even if only in part, poses the risk of serious health problems. There is also the risk of damaging the device or parts of the operator's plant.



CAUTION!

Disregarding these instructions can result in damage to the device or to parts of the operator's plant.



INFORMATION!

These instructions contain important information for the handling of the device.



LEGAL NOTICE!

This note contains information on statutory directives and standards.



• **HANDLING**

This symbol designates all instructions for actions to be carried out by the operator in the specified sequence.

➔ **RESULT**

This symbol refers to all important consequences of the previous actions.

1.7 Safety instructions for the operator



WARNING!

*In general, devices from the manufacturer may only be installed, commissioned, operated and maintained by properly trained and authorized personnel.
This document is provided to help you establish operating conditions, which will permit safe and efficient use of this device.*

2.1 Scope of delivery

**INFORMATION!**

Inspect the packaging carefully for damages or signs of rough handling. Report damage to the carrier and to the local office of the manufacturer.

**INFORMATION!**

Do a check of the packing list to make sure that you have all the elements given in the order.

**INFORMATION!**

Look at the device nameplate to ensure that the device is delivered according to your order. Check for the correct supply voltage printed on the nameplate.

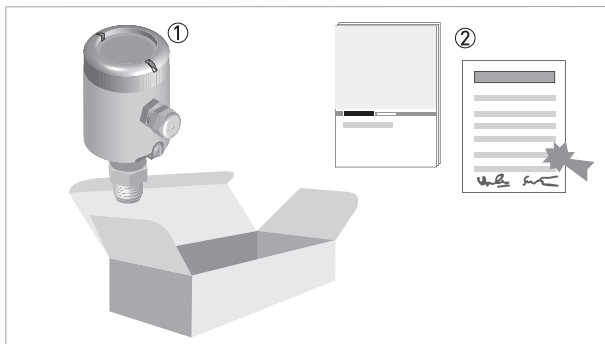

Figure 2-1: Scope of delivery

① Device in the version as ordered.

② Documentation (calibration protocol, factory and material certification (if ordered) and product documentation)

**INFORMATION!**

Assembly materials and tools are not part of the delivery. Use the assembly materials and tools in compliance with the applicable occupational health and safety directives.

2.2 Description of device

The pressure transmitter is designed solely for the direct measurement of process pressures and indirect hydrostatic level measurement. In addition to the main measuring parameters, it is also possible to measure the sensor temperature.

Use internal push buttons to set the device for the zero-point, span and sensor mounting correction. An optional display and adjustment module makes this and other settings possible using 4 push buttons in conjunction with a LCD display.

For all measuring ranges a piezoresistive measuring cell is used. The pressure is transmitted by way of a separating diaphragm and a liquid fill to a measuring element. The measuring element features resistors that change their resistance value based on the mechanical force, enabling the applied pressure to be inferred.

Communication takes place via an analogue 4...20 mA current signal in 2-wire technology with superimposed HART[®] signal.

The measuring device is supplied ready for operation. The factory settings for the process data correspond to the order specifications.

2.2.1 Device design

The following exploded drawing shows the general design.

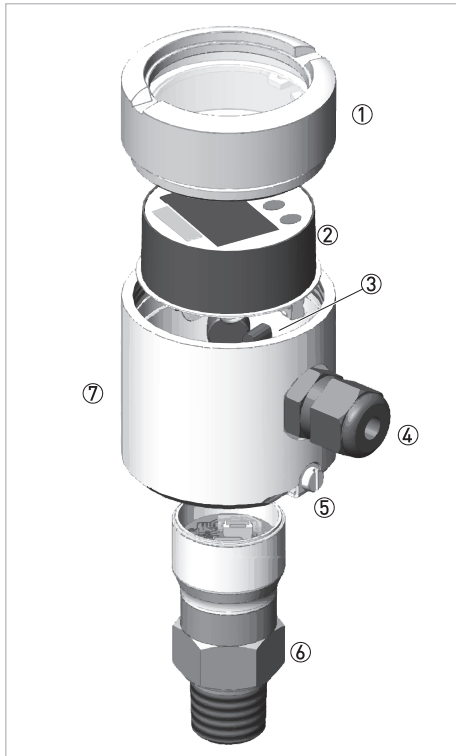

Figure 2-2: Device design

- ① Stainless steel lid
- ② Display unit (optional)
- ③ Converter module
- ④ Cable entry
- ⑤ Grounding screw
- ⑥ Process connection with built-in pressure cell
- ⑦ Stainless steel housing

The venting element is placed on the back side of the pressure transmitter.

2.2.2 Process connection variants

The following process connection variants are available:

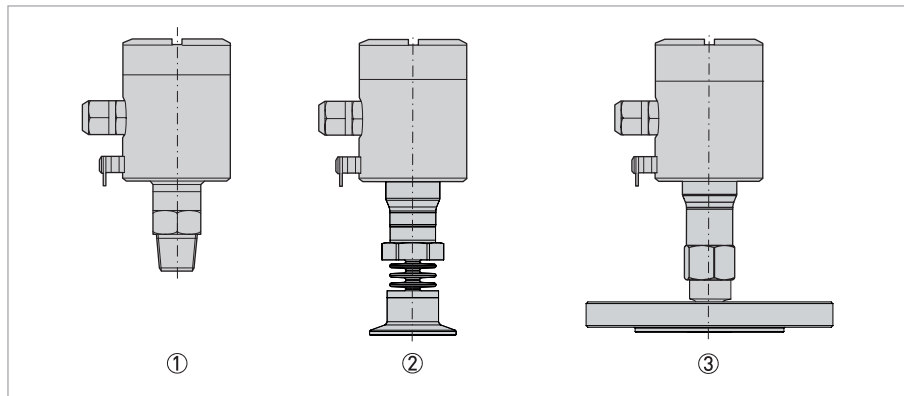

Figure 2-3: Process connection variants

- ① Threaded process connections
- ② Hygienic process connections
- ③ Diaphragm seal assembly OPTIBAR DSP series with flanged process connection

2.3 Nameplates



INFORMATION!

Look at the device nameplate to ensure that the device is delivered according to your order. Check for the correct supply voltage printed on the nameplate.

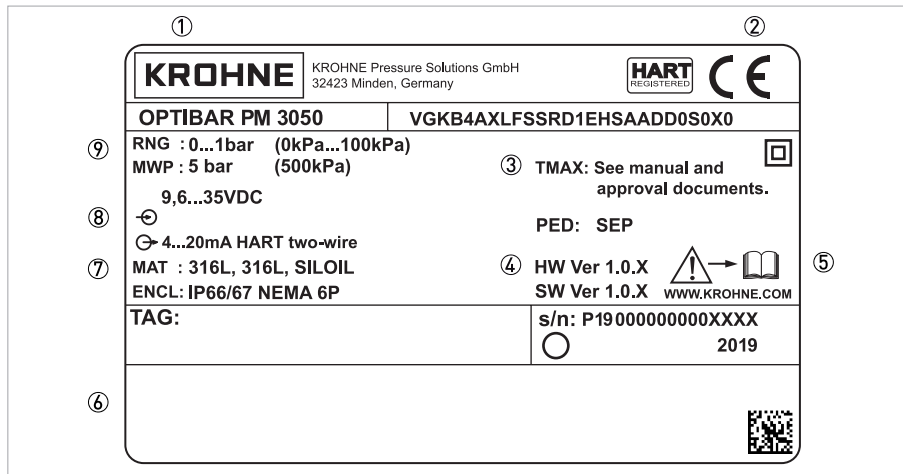

Figure 2-4: Example for a nameplate

- ① Manufacturer logo and address, Product name and type code
- ② CE marking and marking of notified body
- ③ Permissible temperature range
- ④ Hardware and Software version
- ⑤ Observe the installation and operating instructions
- ⑥ Approvals and approval guidelines
- ⑦ Ingress protection and material of wetted parts (Diaphragm, process connections, fill fluid)
- ⑧ Electronics power supply and signal output
- ⑨ Nominal range, permissible process pressure

3.1 General notes on installation

**INFORMATION!**

Inspect the packaging carefully for damages or signs of rough handling. Report damage to the carrier and to the local office of the manufacturer.

**INFORMATION!**

Do a check of the packing list to make sure that you have all the elements given in the order.

**INFORMATION!**

Look at the device nameplate to ensure that the device is delivered according to your order. Check for the correct supply voltage printed on the nameplate.

3.2 Storage

**INFORMATION!**

Observe the storage information found on the packaging. Labels on the original packaging must always remain legible and may not be damaged.

- Store the device in a dry, dust-free location.
- Avoid continuous direct sunlight.
- Store the device in the original packaging.
- Storage temperature: -40...+85°C / -40...+185°F

3.3 Transport

- Use original packaging for transport and ensure that the packaging does not get crushed or damaged by sharp objects or other boxes.
- Observe any transportation information found on the packaging.
- When transporting by ship, use seaworthy outer packing.

3.4 Installation specifications

**INFORMATION!**

Observe the relevant directives, ordinances, standards and accident prevention regulations (e.g. VDE/VDI 3512, DIN 19210, VBG, Elex V, etc.).

The accuracy of the measurement is only guaranteed if the transmitter and accompanying impulse line(s), if any, have been correctly installed. In addition, extreme ambient conditions including large fluctuations in temperature, vibrations and shocks should be kept as far away as possible from the measuring equipment.

3.5 Mounting

**WARNING!**

Do not screw in using the housing! Tightening this way can cause damage to the rotary mechanism on the housing.

For devices with threaded process connections, the hexagon should be tightened with a suitable wrench. For further information refer to *Dimensions and weights* on page 43.

**CAUTION!**

- *Prior to installing the transmitter, it is essential to verify whether the version of the device on hand completely fulfils the technical and safety requirements of the measuring point. This applies in particular to the measuring range, overpressure resistance, temperature, explosion protection and operating voltage.*
- *Check the materials used for the wetted parts (e.g. gasket, process connection, separating diaphragm etc.) for suitability as regards process compatibility.*
- *The device must not be heated by radiated heat (e.g. exposure to the sun) to an electronics housing surface temperature above the maximum permissible ambient temperature. If it is necessary to prevent damage from heat sources, a heat protection (e.g. sun shade) has to be installed.*

3.5.1 Sealing and screwing-in

Connecting G1/2" DIN EN 837-1:

A flat gasket in accordance with DIN EN 837-1 is required for sealing.

NPT thread connection:

Seal the thread with Teflon or other similar permissible, resistant sealing material.

Process connection for special connections:

Information regarding the installation of variants with special connections is available from the manufacturer on request.

3.5.2 Humidity

Use a suitable cable and tighten the cable gland in accordance with the recommended torque specifications. Protect the transmitter from penetrating moisture by dropping the cable down before the screw connection. Any liquids running along the cable will thus drip off before reaching the screw connection; refer to *Laying electrical cables correctly* on page 21. This is particularly important for unprotected installation outside or in rooms in which moisture is an issue (e.g. as a result of cleaning processes) or on cooled or heated containers.

3.5.3 Pressure connection via impulse line

Bear the following in mind when connecting the pressure connection via an impulse line:

- Select the shortest impulse line possible and lay without sharp bends.
- Avoid deposits and blockages in the impulse line. Accordingly, lay the impulse line so that such occurrences are impossible. Do not exceed a drop or rise of approx. 8% in the pipe.
- Ensure that the impulse line flows freely before the connection and rinse with compressed air or, even better, with the product itself.
- When measuring liquid, the impulse line must be completely purged of air.
- Run the impulse line so that trapped air (when measuring liquids) or condensate (when measuring gas) can flow back into the process line.
- Hot steam must not enter the process connection (the excess temperature will destroy the device). To avoid this situation, a suitable water trap (such as a U-tube filled with water prior to installation) can be installed upstream from the measuring device.
- Ensure that the connection is perfectly sealed!

3.5.4 Opening the device, installing and dismantling the graphic display



DANGER!

Check whether the ambient air around the signal converter is explosive. Opening the signal converter in an explosive atmosphere may result in ignition and explosion.



DANGER!

The product may cause the signal converter to become extremely hot. Possible risk of burning. For this reason, promptly shut off the process or isolate the signal converter sufficiently from the product prior to starting work and check that the converter has cooled down to room temperature.



DANGER!

For devices used in hazardous areas, additional safety notes apply; please refer to the Ex documentation.

Electrically, the graphic display is connected to the device using a plug connector on the connection board with the aid of a flying lead. The display is mechanically fixed by way of a spacer plugged into the connection board. For optimal readability, the display can be rotated on this bracket by 350°, adjusting to any of the pressure transmitter's possible installation positions.



Procedure

- Ensure that the signal converter has been de-energised!
- Remove the housing cover from the signal converter by hand.
If the housing cover is stuck and cannot be moved by hand, use a suitable square material to carefully remove it. Place this tool in the flaring located in the housing cover. Take care not to damage the optionally available window cover! Use a lever action to now carefully apply greater torque to loosen it. As soon as the housing cover opens, put the tool away and turn the cover by hand until it opens.
- Ensure that no moisture gets into the device while it is open (drops, spray, liquid mist, etc. ...).
- If there is a display, it can be removed by pulling it forward gently. Pay attention to the connecting cable between the device and the display. To completely remove the display, the connecting cable must be carefully pulled out of the connector on the board.
- ➡ The connection board is now available for further work.
- To install the display and close the housing, follow the steps in reverse order.
Note that the housing covers for devices with displays and devices without displays are different heights. Never attempt, even on a temporary basis, to install a housing cover for a blind device on a device with an installed display.



INFORMATION!

Each time a housing cover is opened, the thread should be cleaned and greased. Use only resin-free and acid-free grease.

Ensure that the housing gasket is properly fitted, clean and undamaged.

3.6 Ventilating the pressure sensor

In the case of gauge pressure transmitters, mechanical reasons make it necessary to charge the reference side of the pressure sensor with atmospheric pressure.

For the IP66/67 (NEMA 4X) and IP66/68 (NEMA 4X / 6P) versions, a vented cable fitted with a capillary tube must be used. In the process, ensure that the capillary tubes are vented in a dry room protected from moisture and that no dust or moisture can penetrate the capillary tube opening.

4.1 Safety instructions

**DANGER!**

All work on the electrical connections may only be carried out with the power disconnected.
Take note of the voltage data on the nameplate!

**DANGER!**

Observe the national regulations for electrical installations!

**DANGER!**

For devices used in hazardous areas, additional safety notes apply; please refer to the Ex documentation.

**WARNING!**

Observe without fail the local occupational health and safety regulations.
Any work done on the electrical components of the measuring device may only be carried out by properly trained specialists.

**INFORMATION!**

Look at the device nameplate to ensure that the device is delivered according to your order.
Check for the correct supply voltage printed on the nameplate.

4.2 Notes for electrical cables

**DANGER!**

The device must be grounded to a spot in accordance with regulations in order to protect personnel against electric shocks.

**DANGER!**

Cables may only be connected when the power is switched off! Since the transmitter has no switch-off elements, overcurrent protection devices, lightning protection and/or energy isolating devices need to be provided by the customer.

Metric thread M16 x 1.5 mm

The cable glands with metric threads are screwed in by the factory. They are sealed using plastic plugs to protect them during transport. Remove these plugs prior to establishing an electrical connection.

4.2.1 Requirements for signal cables provided by the customer



INFORMATION!

If the signal cable was not ordered, it is to be provided by the customer. The following requirements regarding the electrical values of the signal cable must be observed:

Specifications for standard signal cables

- 2 wire cable
- Casing colour: grey
- Colour of wires:
Pair 1: black / red; pair 2: green / white
- Test voltage: ≥ 500 VAC RMS (750 VDC)
- Temperature range: $-40\dots+105^{\circ}\text{C}$ / $-40\dots+221^{\circ}\text{F}$
- Capacity: ≤ 200 pF/m / 61 pF/ft
- Inductance: ≤ 0.7 $\mu\text{H}/\text{m}$ / 0.2 $\mu\text{H}/\text{ft}$

4.2.2 Laying electrical cables correctly

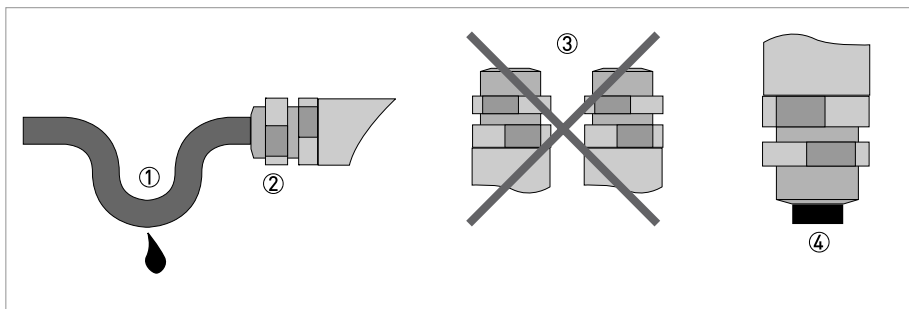

Figure 4-1: Protect housing from dust and water



- ① Lay the cable in a loop just before the housing.
- ② Tighten the screw connections of the cable entry.
- ③ Never mount the housing with the cable entries facing upwards.
- ④ Seal cable entries that are not needed with a plug.

4.2.3 Connection to the power supply

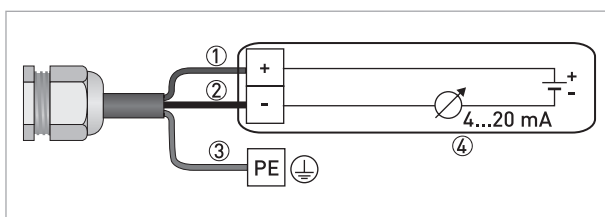

Figure 4-2: Connection to the feed unit

- ① Red
- ② Black
- ③ Green/yellow
- ④ Feed unit with load

4.2.4 Connection with M12 quick disconnect

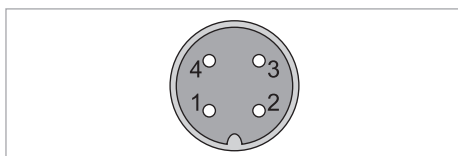

Figure 4-3: M12 quick disconnect plug

- ① Signal +
- ② Not connected
- ③ Signal -
- ④ Grounding

4.3 Electrical connection

The power supply and signal output are connected via screw terminals in the housing. The display and adjustment module is connected to the interface adapter via contact pins.

4.3.1 Cable preparation

The terminals in the terminal compartment are suitable for wire widths from 0.34...2.5 mm². You should remove the cable sheath 40...50 mm / 1.6...2" to ensure proper connection.

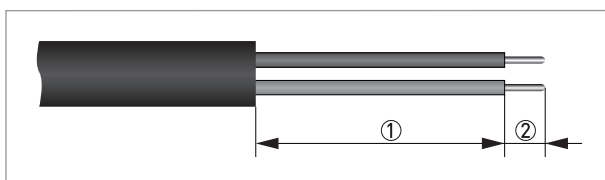

Figure 4-4: Stripping the cable

- ① 40...50 mm / 1.6...2"
- ② 5 mm / 0.2"

4.3.2 Connection in the terminal compartment

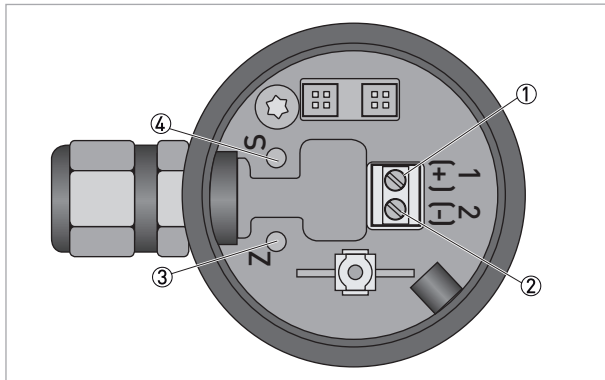

Figure 4-5: Connection in the terminal compartment

- ① (V_{in+}) signal terminals
- ② (V_{in-}) signal terminals
- ③ Push button Zero point (Zero)
- ④ Push button Span point (Span)

4.4 Grounding the measuring device



DANGER!

There should be no difference in potential between the pressure sensor and the housing or protective earth of the transmitter!

- The pressure sensor must be properly grounded.
- Do not use the grounding cable to connect any other electrical devices to ground at the same time.
- The pressure transmitter is connected to ground by means of a functional grounding conductor.
- In hazardous areas, grounding is used at the same time for equipotential bonding.

A ground terminal is provided on the outside of the housing to accommodate wire widths of up to 1.5 mm².

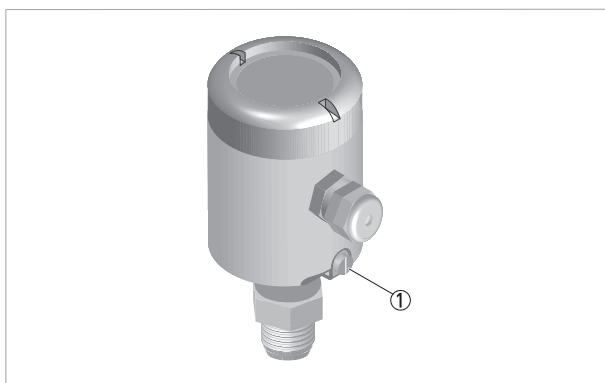

Figure 4-6: Position of the ground terminal on the housing

- ① Ground terminal

4.5 Description of the current output

The current output is a 2-wire 4...20 mA output.

Overload condition:

- Lower limit: 3.8 mA
- Upper limit: 20.5 mA

Alarm current:

- Low alarm current: < 3.6 mA
- High alarm current: > 21 mA

Default setting: Low alarm

The transmitter works with voltages of 12...45 VDC, no load.

$$R_{\text{Load}} [\text{K}\Omega] = (U_{\text{B}} [\text{V}] - 12 \text{ V}) / \text{alarm current max. [mA]}$$

where U_{B} = supply voltage and R_{Load} = max. load resistance (load)

5.1 Start-up

The pressure transmitter may only be started up after it has been completely installed and checked by appropriately qualified personnel. Switch on the operating voltage for start-up. Prior to applying the operating voltage, it is crucial to check the correctness of the process connection and the electrical connection and ensure that the impulse line has been completely filled with the process medium. Then proceed with start-up. If available, the shut-off fixtures are to be activated in the following sequence (all valves are closed in the base setting):



- Open extraction shut-off valve, if any.
- Open shut-off valve, if any.

For shut-down reverse the order.



INFORMATION!

Please note that the absolute pressure transmitters with measuring ranges ≤ 100 kPa abs (1 bara) were affected by the externally present atmospheric pressure during transport and storage.

5.2 Factory settings on delivery

The pressure transmitter factory settings can be based on a measuring span specified by the customer in the order. This and other information is located on the device nameplate. If the customer has not specified any settings, the device always leaves the factory with the following settings:

Device parameter	Factory pre-setting
Lower current value (0% URL)	4 mA
Upper current value (100% URL)	20 mA
Alarm Current	Low Alarm < 3.6 mA
Damping	2.0 seconds
HART® Short Tag	SENSOR
HART® Long Tag	Sensor
HART® Polling Address	0
Unit Pressure	mbar / bar
Unit Temperature	°C
Measuring Rate	20 ms
Main display value [*]	Pressure value in %
Sensor temperature [*]	Display in °C
Write protection [*]	No
Language [*]	English
Contrast [*]	50%
Bargraph indication [*]	Yes

Table 5-1: Overview factory settings

[*] only with an optional display and adjustment module

During a factory reset (which can be selected using the keyboard on the display), the pressure transmitter is automatically started with the above factory settings.

5.3 General operation

Both the configuration options and the procedure for adjusting the measuring device parameters are considerably different for the blind version compared to the version with the operating and adjustment module. With such a module, other setting and configuration options are available without requiring push buttons on the connection board. For this reason, the settings for each version are described separately below.

5.4 Operation without display and adjustment module

To configure the device without the display and adjustment module, the housing cover must be open, providing clear access to the push buttons on the connection board.

5.4.1 Sensor mounting correction (offset)

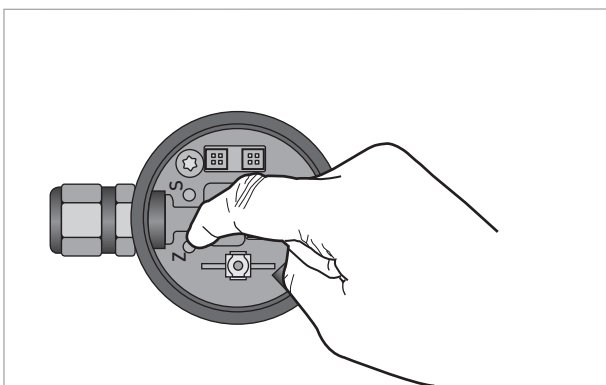

Figure 5-1: Sensor mounting correction

When delivered, the measuring device is set up for vertical installation (cover opens to the top). Zero point offsets (e.g. slightly slanted mounting position) may occur when installing the pressure transmitter and they must be eliminated. Hold the push button down for at least 10 seconds and release within 30 seconds.



INFORMATION!

Prior to starting with the correction, ensure that the pressure transmitter has already reached its operating temperature (approx. 5 minutes operating time, where the pressure transmitter has already reached the ambient temperature).

5.4.2 Zero point and lower range limit (4 mA)

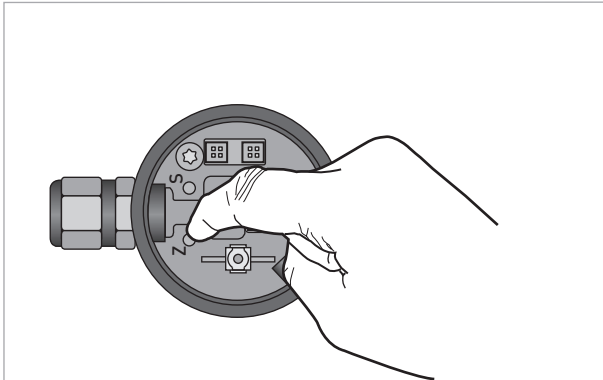

Figure 5-2: Zero point and lower range limit

The pressure must be stable with sufficient accuracy for the application. Hold the push button down for at least 1 second and release within 5 seconds. This way the lower range value is stored in a fail-safe memory.

5.4.3 Span and upper range limit (20 mA)

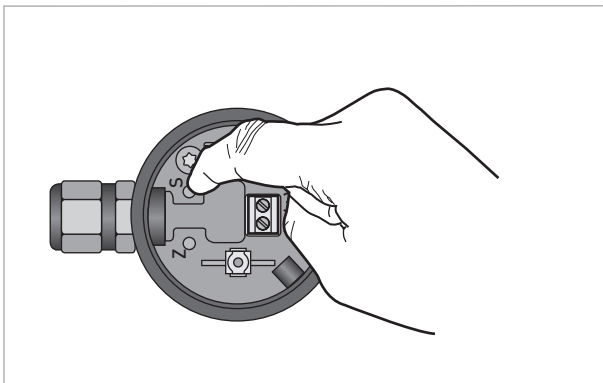

Figure 5-3: Span and upper range limit

The pressure must be stable with sufficient accuracy for the application. Hold the push button down for at least 1 second and release within 5 seconds. This way the upper range value is stored in a fail-safe memory.

5.4.4 Factory reset

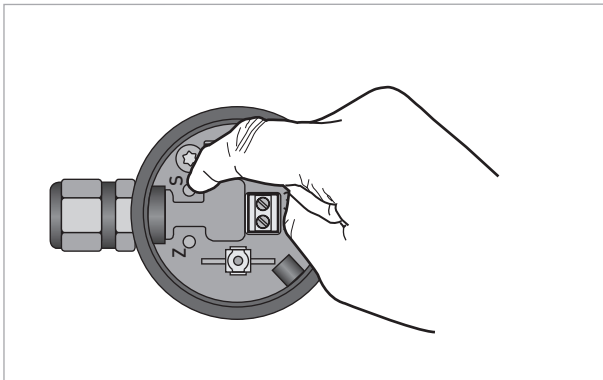

Figure 5-4: Factory reset

Hold the push button down for at least 10 seconds and release within 30 seconds. The pressure transmitter now resets itself and loads the factory settings (see details on page 25).



INFORMATION!

A Factory reset is possible despite write protection.

5.5 Operation with display and adjustment module

5.5.1 Display and operating elements

The following illustrations show examples of the display while in measuring mode, in the selection menu and when configuring measurement values.

Display during measuring mode

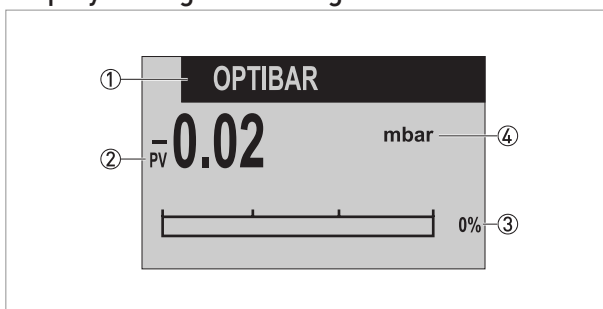

Figure 5-5: Example of display during normal measuring mode

- ① TAG ID
- ② Measured value
- ③ Bargraph indication in %
- ④ Unit of measured value

Display in selection menu

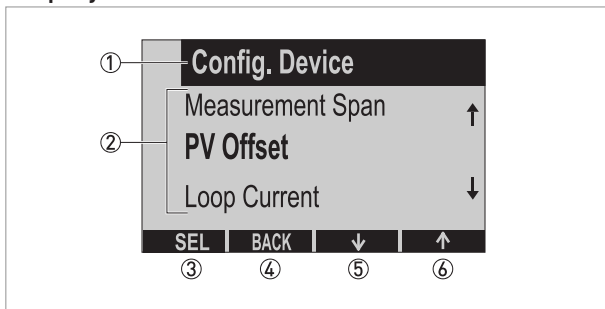

Figure 5-6: Example of display in the selection menu for device configuration

- ① Selected main menu
- ② List of possible submenus
- ③ Button for menu selection (SEL)
- ④ Button used to go back one level in the menu (BACK)
- ⑤ Button in the menu used to navigate down the list (↓)
- ⑥ Button in the menu used to navigate up the list (↑)

Display for configuration of settings

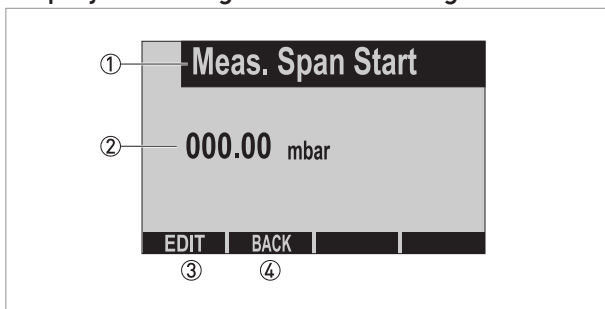

Figure 5-7: Example of display when editing the setting values

- ① Menu name of setting value
- ② Setting value to be edited and corresponding unit
- ③ Button to select editing mode (EDIT)
- ④ Button used to go back one level in the menu (BACK)

Navigation in the operating menu

	MENU		SEL		EDIT	
	→		→		→	
Normal operation		Config. menu		Editing menu		Edit
	←		←	↑↓	←	
	BACK		BACK	SAVE QUIT	BACK	

5.5.2 Structure of the operating menu

Measuring mode/menu	Function of the existing buttons
Display mode and normal mode	MENU: indicate menu
	BACK: back to indication
	• ↓: contrast darker
	• ↑: contrast lighter
Selection mode and configuration menu	SEL: select menus
	BACK: one level back
	↓: navigate down the list
	↑: navigate up the list
Editing menu	Edit numerical value:
	SEL: select digit position
	BACK: store
	↓: reduce value or browse character map
	↑: increase value or browse character map
	Confirm set numerical value:
	EDIT: back to editing mode
	BACK: one level back
	QUIT: reset to original value
	SAVE: save new value
	Selection from list or confirm action:
	SAVE: save selection
	BACK: one level back
	↓: navigate down the list
	↑: navigate up the list

Table 5-2: Overview structure of the operating menu

5.5.3 Description of the function

Main Menu	Submenu	description	
Configuration	Sensor mounting correction	Automatically or manually corrects sensor mounting.	
	Units	Selection of units for the pressure and temperature values.	
	Damping		PV damping constant for the analogue current output and HART®.
			0 seconds: no damping
			0.5 seconds: digital value filter with PT1 element 1.0 seconds and more: only PT1 element
	Adjustment	Automatically or manually adjusts the zero point and measuring span	
	Alarm Current	Selection of the alarm current.	
	Output direction	Selection of the current output characteristic.	
	Output Range	Selection of the current output limits.	
	Service	Service menu for qualified users.	
	HART®	Polling address and preamble bytes	
	Tag Name	Specifies the name of the device (maximum 16 characters).	
	Write Protection	Switches write protection for the transmitter on or off. A factory reset is possible via the push button despite write protection. Default PIN: 3050.	
Factory reset	Resets all settings to those configured at the factory.		
Display	Value on display	Selection of the measured value on display.	
	Unit Pressure	Selection of the units for the pressure and temperature values on the display.	
	Bargraph	Activates or deactivates the bar graph in the start view. The bar graph indicates the output in percent (0...100%) of the measuring span.	
	Contrast	Setting option to increase or decrease the display contrast (between 30...100%).	
	Language	Selection of display language. The softkeys remain hereby excluded.	
Diagnosis ①	Measured values	Display of respective current output values.	
	Peak value	Peak values for the pressure, sensor and electronic temperature measured values.	
	simulation	Simulation of the output values for pressure, sensor and electronic temperature. The simulation ends automatically after 60 min.	
	System time	Display on the hour counter.	
	Devices info	Information about the device, serial number etc.	

Table 5-3: Description of the function

① Also available when write protection is enabled.

6.1 Replacing the pressure sensor, the electronics and the display



DANGER!

All work on the electrical connections may only be carried out with the power disconnected. Take note of the voltage data on the nameplate!



DANGER!

Check whether the ambient air around the pressure transmitter is explosive. Opening the device in an explosive atmosphere may result in ignition and explosion.



DANGER!

The product may cause the pressure transmitter to become extremely hot. Possible risk of burning. For this reason, promptly shut off the process or isolate the pressure transmitter sufficiently from the product prior to starting work and check that it has cooled down to room temperature.



WARNING!

Observe without fail the local occupational health and safety regulations. Any work done on the electrical components of the measuring device may only be carried out by properly trained specialists.

Pressure sensor and electronics

When used as intended in normal operation, the pressure transmitter is completely maintenance-free. For this type of device, the manufacturer makes no provision for repairs, replacement of electronics or measuring element for the user. To ensure safe operation, the entire device must be replaced in the event of damage to or failure of the pressure sensor or the electronics. The replaced device may not be repaired for reasons of safety. Please clearly mark the device as defective and dispose of it properly.



CAUTION!

Adhere to national disposal regulations. Proper disposal avoids negative consequences for people and the environment and allows valuable raw materials to be recycled.

Display

A faulty display cannot be repaired but can only be replaced by a new display module. In this case, however, the cause of the damage or failure of the graphic display must be identified. If the failure can be traced back to the overheating or overloading of the device, the entire device must be clearly marked as defective, replaced and disposed of properly. Repairs are not permitted.



INFORMATION!

For more detailed information please contact your local representative.

6.2 Spare parts availability

The manufacturer adheres to the basic principle that functionally adequate spare parts for each device or each important accessory part will be kept available for a period of 3 years after delivery of the last production run for the device.

This regulation only applies to spare parts which are subject to wear and tear under normal operating conditions.

6.3 Availability of services

The manufacturer offers a range of services to support the customer after expiration of the warranty. These include repair, maintenance, technical support and training.

**INFORMATION!**

For more precise information, please contact your local sales office.

6.4 Repairs

Repairs must be carried out exclusively by the manufacturer or the manufacturer authorised specialist companies.

6.5 Returning the device to the manufacturer

6.5.1 General information

This device has been carefully manufactured and tested. If installed and operated in accordance with these operating instructions, it will rarely present any problems.

**WARNING!**

Should you nevertheless need to return a device for inspection or repair, please pay strict attention to the following points:

- *Due to statutory regulations on environmental protection and safeguarding the health and safety of the personnel, the manufacturer may only handle, test and repair returned devices that have been in contact with products without risk to personnel and environment.*
- *This means that the manufacturer can only service this device if it is accompanied by the following certificate (see next section) confirming that the device is safe to handle.*

**WARNING!**

If the device has been operated with toxic, caustic, radioactive, flammable or water-endangering products, you are kindly requested:

- *to check and ensure, if necessary by rinsing or neutralising, that all cavities are free from such dangerous substances,*
- *to enclose a certificate with the device confirming that it is safe to handle and stating the product used.*

6.5.2 Form (for copying) to accompany a returned device



CAUTION!

To avoid any risk for our service personnel, this form has to be accessible from outside of the packaging with the returned device.

Company:		Address:	
Department:		Name:	
Tel. no.:		Fax no. and/or Email address:	
Manufacturer's order no. or serial no.:			
The device has been operated with the following medium:			
This medium is:	<input type="checkbox"/>	radioactive	
	<input type="checkbox"/>	water-hazardous	
	<input type="checkbox"/>	toxic	
	<input type="checkbox"/>	caustic	
	<input type="checkbox"/>	flammable	
	<input type="checkbox"/>	We checked that all cavities in the device are free from such substances.	
<input type="checkbox"/>	We have flushed out and neutralized all cavities in the device.		
We hereby confirm that there is no risk to persons or the environment through any residual media contained in the device when it is returned.			
Date:		Signature:	
Stamp:			

6.6 Disposal



LEGAL NOTICE!

Disposal must be carried out in accordance with legislation applicable in your country.

Separate collection of WEEE (Waste Electrical and Electronic Equipment) in the European Union:



According to the directive 2012/19/EU, the monitoring and control instruments marked with the WEEE symbol and reaching their end-of-life **must not be disposed of with other waste**.

The user must dispose of the WEEE to a designated collection point for the recycling of WEEE or send them back to our local organisation or authorised representative.

7.1 Measuring principle

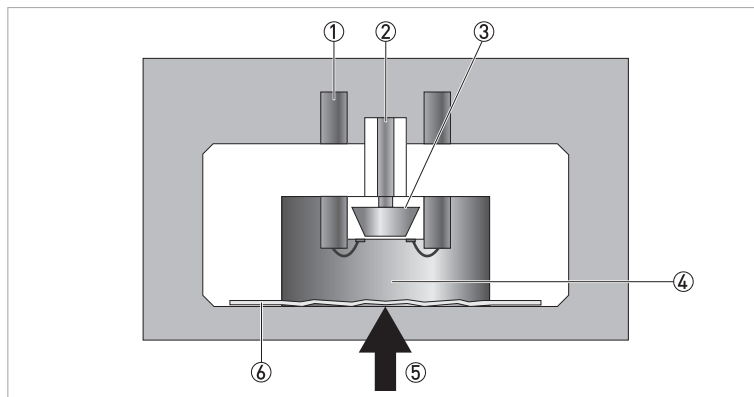

Figure 7-1: Piezoresistive measuring principle for pressure measurement

- ① Signal cables of measuring bridge
- ② Ventilation (only with gauge pressure transmitters)
- ③ Sensor with piezoresistive elements
- ④ Fill fluid
- ⑤ Process pressure "P"
- ⑥ Metallic diaphragm

The process pressure is transmitted from the metallic diaphragm ⑥ via the fill fluid behind it ④ directly to the measuring cell. The embedded piezoresistive measuring elements on the sensor with piezoresistive elements ③ experience a corresponding strain which is then converted via a Wheatstone Bridge circuit to a voltage proportional to the applied process pressure.

Absolute pressure, gauge pressure and vacuum can be measured using this measuring principle.

Available measurement configurations

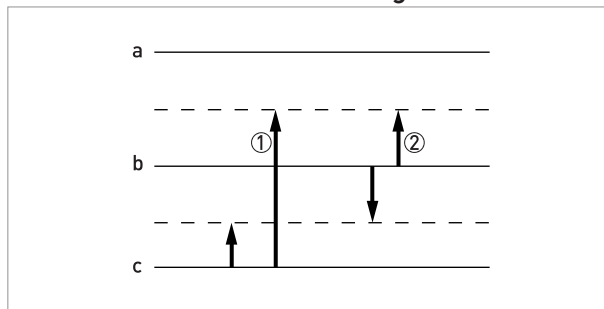

Figure 7-2: Available measurement configurations

a: P_e = Effective pressure [2 bar]

b: P_{amb} = Ambient pressure [1.013 bar]

c: P_0 = Vacuum [0 bar]

① Absolute pressure [1.513 bara]

② Gauge pressure [0.5 barg]

Absolute pressure

During the production process, the sensor is evacuated on the negative side of the measuring cell and then sealed and referenced against a vacuum.

The pressure transmitter now measures the absolute pressure ① compared to a "zero" pressure in an empty space (vacuum).

Gauge pressure

The back of the sensor is open to the atmosphere via air ventilation. The device is thus automatically referenced to the continuously changing ambient air pressure, indicating the gauge pressure ② in the process compared to the respective atmospheric pressure.

7.2 Technical data



INFORMATION!

- The following data is provided for general applications. If you require data that is more relevant to your specific application, please contact us or your local sales office.
- Additional information (certificates, special tools, software,...) and complete product documentation can be downloaded free of charge from the website (Downloadcenter).

Measuring system

Measuring principle	Metallic diaphragm with piezoresistive measuring cell
Application range	Measurement of absolute and gauge pressure of gases, vapours and liquids.
Measuring range	Relative pressure: (-100) 0...+100 mbar up to (-1) 0...+100 bar / (-1,5) 0...+1.5 psi up to (-15) 0...+1500 psi Absolute pressure: 0...400 mbar up to 0...40 bar / 0...6 psi up to 0...580 psi
Display and user interface	
Display on signal converter	<ul style="list-style-type: none"> • Dot-matrix display 32 x 20 mm / 1.26 x 0.79" • Display infinitely rotatable by 350° • Ambient temperatures below -20°C / -4°F may affect the readability of the display
Display function	<ul style="list-style-type: none"> • Display of measured value or derived measured value such as filling height • Warning and diagnostic information • All parameters are accessible via the operating menu
Operating and display languages	German, English, Spanish and French
Operating	Local operation via 4 softkeys on the display and adjustment module
Remote control	<ul style="list-style-type: none"> • PACTware™ via GenericHART® • HART® Handheld Communicator from Emerson Process

Measuring accuracy

Reference conditions acc. to DIN 61298-1	<ul style="list-style-type: none"> • Ambient temperature (constant): +15...+25°C / +59...+77°F • Relative humidity (constant): 45...75% • Ambient pressure (constant): 860...1060 mbar / 12.5...15.4 psi • Measuring accuracy according to IEC 61298-2 (terminal based) • Curve characteristic: linear • Vertical mounting position, measuring diaphragm pointing down • Effect of mounting position < 0.2 mbar/20 Pa (0.003 psig) • Deviation at current output due to strong, high-frequency electromagnetic fields within the scope of EN 61326 		
Reference accuracy acc. to DIN EN 60770	Includes the non-linearity, hysteresis and repeatability under reference conditions. Applies to the digital interfaces as well as for the analogue 4...20 mA current output. [% of the calibrated span]		
	Accuracy class	0.10%	0.20%
	TD of 1:1 to 5:1	< ± 0.1%	< ± 0.2%
	TD > 5:1	< ± 0.025% + 0.015% x TD	< ± 0.05% + 0.03% x TD

Effect of ambient or medium temperature	Temperature effect on zero and span in relation to the set measuring span. Applies to the digital interface HART® as well as for the analogue 4...20 mA current output. [% of the calibrated span]		
	Threaded process connections with recessed diaphragm		
	In combination with OPTIBAR DS diaphragm seals, additional effects have to be considered		
	Measuring range	-10...+60°C / +14...+140°F	-40...+85°C / -40...+185°F
	400 mbar / 6 psi	< ± 0.12% + 0.12% x TD	< ± 0.15% + 0.15% x TD
	1 bar / 15 psi		
	4 bar / 60 psi		
	10 bar / 150 psi		
	40 bar / 600 psi		
	100 bar / 1500 psi		
	Threaded process connections with front flush diaphragm		
	Measuring range	-10...+60°C / +14...+140°F	-40...+85°C / -40...+185°F
	400 mbar / 6 psi	G1": < ± 0.12% + 0.12% x TD	G1": < ± 0.15% + 0.15% x TD
	1 bar / 15 psi	G1": < ± 0.12% + 0.12% x TD G1/2": < ± 0.12% + 0.2% x TD	G1": < ± 0.15% + 0.15% x TD G1/2": < ± 0.15% + 0.3% x TD
	4 bar / 60 psi	< ± 0.12% + 0.12% x TD	< ± 0.15% + 0.15% x TD
	10 bar / 150 psi		
	40 bar / 600 psi		
	Hygienic and front flush process connections 1", DN25		
	Measuring range	-10...+60°C / +14...+140°F	-40...+85°C / -40...+185°F
	400 mbar / 6 psi	< ± 0.12% + 0.6% x TD	< ± 0.15% + 0.8 x TD
1 bar / 15 psi			
4 bar / 60 psi	< ± 0.12% + 0.3% x TD	< ± 0.15% + 0.4 x TD	
10 bar / 150 psi			
40 bar / 600 psi			
Hygienic and front flush process connections			
Measuring range	-10...+60°C / +14...+140°F	-40...+85°C / -40...+185°F	
400 mbar / 6 psi	< ± 0.12% + 0.4% x TD	< ± 0.15% + 0.5 x TD	
1 bar / 15 psi			
4 bar / 60 psi	< ± 0.12% + 0.2% x TD	< ± 0.15% + 0.25 x TD	
10 bar / 150 psi			
40 bar / 600 psi			
Effect of mounting position	A position-dependent zero offset can be corrected. Factory calibration with process diaphragm pointing downwards.		
	≤0.1 mbar per 10° inclination		
Long-term stability acc. to DIN 16086 and IEC 60770-1	Applies to the digital interface HART® as well as for the analogue 4...20 mA current output. [% of URL]		
	<± 0.1% x TD within 1 year		
Ambient temperature effect on analogue current output	<± 0.1% of URL, within -40...+85°C / -40...+212°F		

Total performance	The total performance includes the non-linearity, hysteresis and repeatability with the effects of ambient and process temperature on zero and span. This statement shows an excerpt of all possible combinations for the temperature range of -40...+85°C (-40...+185°F), a turn-down of 1:1 and the accuracy class of 0.1% with 4...20 mA HART output. [% of calibrated span]		
	Measuring range	Threaded recessed process connections	Hygienic and front-flush process connection
	400 mbar / 6 psi	<± 0.32	<± 0.66
	1 bar / 15 psi	<± 0.32	<± 0.41
	4 bar / 60 psi	<± 0.32	<± 0.41
	10 bar / 150 psi	<± 0.32	<± 0.41
40 bar / 600 psi	<± 0.32	<± 0.41	

Operating conditions

Version	Ambient temp.	Process temp.	Storage and transport temperature
Standard (without cooling fins)	-40...+85°C / -40...+185°F	-40...+105°C / -40...+221°F	-40...+85°C / -40...+185°F
Front-flush with cooling fins		-40...+150°C / -40...+302°F	
With OPTIBAR DS diaphragm seals	-70...+400°C / -94...+752°F		

Further operating conditions

Protection category according to IEC 529 / EN 60529	Single chamber Housing, IP66 / IP67, NEMA 6P (depends on electrical connection)
Vibration	
Reference conditions	Stainless steel, single chamber housing, process connection thread G1/2" EN 837-1
Vibration resistance acc. to EN 60068-2-6	4 g at 5...200 Hz
Shock resistant according to EN 60068-2-27	100 g, 6 ms (mechanical shock)

Materials

Wetted parts	
Process connection	316L / 1.4404
Diaphragm	316L / 1.4435
Fill fluid	Recessed process connection: Silicone oil Front-flush process connection: Synthetic oil FDA compliant
Gasket for process connection (included)	DU - Thread G1/2 EN837-1: NBR fiber-glass bonded (C-4400)

Non-wetted parts	
Housing	316L / 1.4404
Lid sealing ring	EPDM
Housing lid	316L / 1.4404
Sight glass	Makrolon
Grounding screw	316L / 1.4404
Cable gland	Plastic (polyamide) black; nickel-plated brass; 316 / 1.4305

Process connection

Type	<ul style="list-style-type: none"> • Threaded connections • EN Flanges DN 25 - 100 • ANSI Flanges 1"...3" • Prepared for Diaphragm Seal (only process connection DL - Thread ANSI 1/2"NPT-F) • Front-flush hygienic connections
Tightening torques	
Maximum tightening torques for the process connection	
Thread G1/2 EN837-1 (male)	30 Nm / 22 ft lb

Electrical connection

Mechanical			
Cable gland	Type	Ingress Protection	Cable diameter
	A - M16 x 1.5 plastic	IP66/67 NEMA 4X	4.5...10 mm / 0.18...0.39"
	E - M16 x 1.5 nickel plated brass	IP66/67 NEMA 4X	4.5...10 mm / 0.18...0.39"
	X - M16 x 1.5 316L	IP66/68 NEMA 4X / 6P	4...11 mm / 0.16...0.43"
	C - M12 4-pin quick disconnect	IP66/67 NEMA 4X	n/a
Wire cross-section	Solid wire with cords: 0.34 mm...2.5 mm ² / AWG 22...14		
	Cord with wire end sleeve: 0.34 mm...1.5 mm ² / AWG 22...16		
Electrical			
Operating voltage	Non-Ex device: 12...45 VDC		
Reverse polarity protection	Integrated		
Permissible residual ripple	for U_n 12 VDC ($12 < U_B < 14$ VDC) $\leq 0.7 V_{eff}$ (16...400 Hz)		
Load	$R_{L, max} = (U_B - 12) / 22$ mA		
Potential connection in device	Electronics: not electrically isolated		
	Ground terminal: galvanically connected with process connection		
Over voltage category	III		
Protection class	II		

Inputs / outputs

Output signal	
Output signal	4...20 mA / HART® version 7.5 3.8...20.5 mA (factory setting acc. to NAMUR recommendation)
Signal resolution	0.3 µA
Error signal of current output (adjustable)	High alarm ≥ 21 mA Low Alarm ≤ 3.6 mA
Max. output current	24 mA
Boot-up current	≤ 5 mA for 15 ms after switching on, then ≤ 3.6 mA
Damping	0.0 seconds: no damping
	0.5 seconds: with digital filter + PT1 element
	from 1.0 second: 63% of the input measurement from 1...30 seconds can be set in 1 second increments.
Boot-up time first measurement value	3.5 seconds

Approvals and certificates

CE	The device complies with the legal requirements of the EU directive. The manufacturer confirms compliance with these regulations by affixing the CE marking.
Electromagnetic compatibility (EMC)	EMC conformity for EN 61326-1:2013 and EN 61326-2-3:2013
NAMUR	NE 21 - Electromagnetic compatibility of equipment NE 43 - Signal level for the failure information of digital transmitters NE 53 - Compatibility of field devices and display/adjustment components NE 107 - Self-monitoring and diagnosis of field devices
Classification according to Pressure Equipment Directive (PED 2004/108/EC)	For gases of fluid group 1 and liquids of fluid group 1, the requirements are fulfilled according to article 4, paragraph 3 (sound engineering practice).
RoHS	The device complies with the Directive 2011/65/EU of the European Parliament and of the Council on the restriction of the use of certain hazardous substances in electrical and electronic equipment
Suitable for hygienic applications	This device was developed for hygienic applications. Especially marked aseptic process connections wetted materials comply with all requirements of the FDA, 3-A Sanitary Standard No. 74-xx and EHEDG. A special marking 3-A and/or EHEDG on the device will confirm this. Further requirements and also restrictions are described in the supplementary instructions.
AD2000	The pressure retaining material 316L (1.4404/1.4435) complies with the AD2000 W2 and W10 guidelines.
Manufacturer Declarations	Depending on the specific configuration of the device, the following documents are available if ordered: FDA conformity, Regulation (EC) 2023/2006 (GMP), Regulation (EC) 1935/2005 (Food contact materials), TSE-free (Transmissible Spongiform Encephalopathies) - free of animal content

7.3 Pressure ranges

Adjustment

Adjustment range of the zero / span adjustment in relation to the nominal range

- Zero (-10...+95%)
- Span (5...+120%)
- Difference between zero and span: max. 120% of the nominal range

Recommended maximum Turn Down (TD): 10:1 (limited to 20:1)

Nominal ranges and overload capacity in bar/kPa

This information is provided as an overview and refers to the measuring cell. Limitations due to the material and design of the process connection as well as the type of pressure selected are possible. The information given on the nameplate applies.

Gauge pressure

Nominal range	Max. working pressure (MWP)	Minimum pressure resistance ①
0...+0.1 bar / 0...+10 kPa	+2.5 bar / +250 kPa	-0.8 bar / -80 kPa
0...+0.4 bar / 0...+40 kPa	+4 bar / +400 kPa	-0.8 bar / -80 kPa
0...+1 bar / 0...+100 kPa	+5 bar / +500 kPa	-1 bar / -100 kPa
0...+4 bar / 0...+400 kPa	+20 bar / +2000 kPa	-1 bar / -100 kPa
0...+10 bar / 0...+1000 kPa	+40 bar / +4000 kPa	-1 bar / -100 kPa
0...+40 bar / 0...+4000 kPa	+100 bar / +10 MPa	-1 bar / -100 kPa
0...+100 bar / 0...+10000 kPa	+300 bar / +30 MPa	-1 bar / -100 kPa
-0.4...+0.4 bar / -40...+40 kPa	+4 bar / +400 kPa	-0.8 bar / -80 kPa
-1...0 bar / -100...0 kPa	+5 bar / +500 kPa	-1 bar / -100 kPa
-1...+1 bar / -100...+100 kPa	+5 bar / +500 kPa	-1 bar / -100 kPa
-1...+4 bar / -100...+400 kPa	+20 bar / +2000 kPa	-1 bar / -100 kPa
-1...+10 bar / -100...+1000 kPa	+40 bar / +4000 kPa	-1 bar / -100 kPa
-1...+40 bar / -100...+4000 kPa	+100 bar / +10 MPa	-1 bar / -100 kPa

Table 7-1: Overview gauge pressure

Absolute pressure

Nominal range	Max. working pressure (MWP)	Minimum pressure resistance ①
0...0.4 bar / 0...+40 kPa	+4 bar / +400 kPa	-1 bar / -100 kPa
0...+1 bar / 0...+100 kPa	+5 bar / +500 kPa	-1 bar / -100 kPa
0...+4 bar / 0...+400 kPa	+20 bar / +2000 kPa	-1 bar / -100 kPa
0...+10 bar / 0...+1000 kPa	+40 bar / +4000 kPa	-1 bar / -100 kPa
0...+40 bar / 0...+4000 kPa	+100 bar / +10 MPa	-1 bar / -100 kPa

Table 7-2: Overview absolute pressure

① The minimum pressure resistance of the measuring cell is applicable under reference conditions only.

7.4 Dimensions and weights

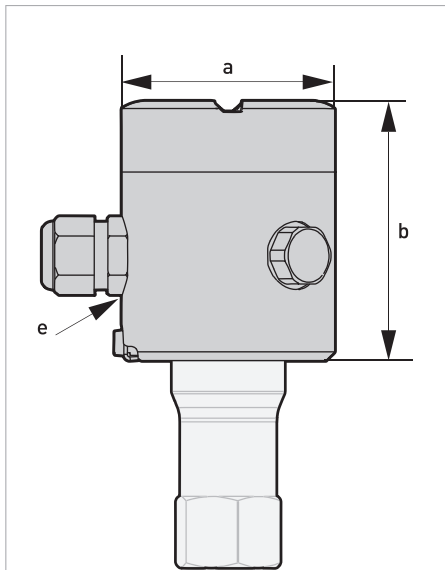

Figure 7-3: Dimension of the enclosure

Dimension	Blind Version		Version with display	
	mm	inch	mm	inch
a	64	2.52	64	2.52
b	65	2.8	73	3.1
e	M16 x 1.5			

Table 7-3: Dimension in mm / inch

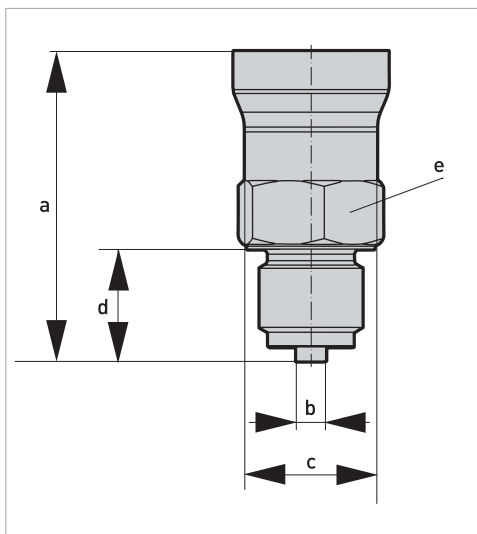

Figure 7-4: Thread ISO 228 G1/2 EN837-1

Dimension	mm	inch
a	56	2.56
b	Ø 6	Ø 0.24
c	Ø 26	Ø 1.02
d	23	0.91
e	SW 27	

Table 7-4: Dimension in mm / inch

Code	Designation	Material	Approvals
DU	Thread ISO228 G1/2"; EN837-1	316L	-

Table 7-5: Order information

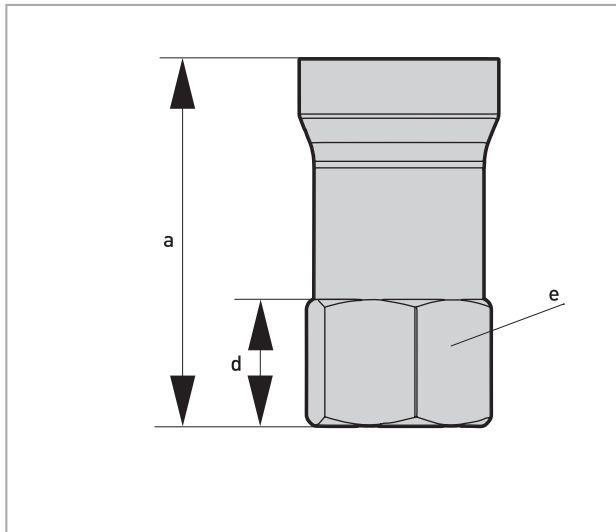

Figure 7-5: Thread ANSI 1/2" NPT female

Dimension	mm	inch
a	59	2.332
d	19	0.75
e	SW 27	

Table 7-6: Dimension in mm / inch

Code	Designation	Material	Approvals
DL	Thread ISO228 1/2" NPT-F	316L	-

Table 7-7: Order information

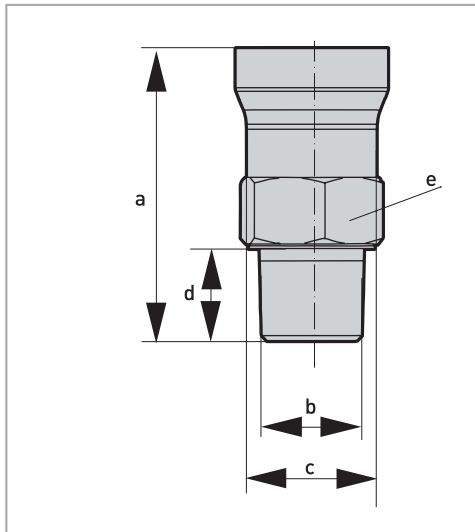

Figure 7-6: Thread ANSI 1/2" NPT male

Dimension	mm	inch
a	62	2.44
c	Ø 26	Ø 1.02
d	19	0.75
e	SW 27	

Table 7-8: Dimension in mm / inch

Code	Designation	Material	Approvals
LY	Thread ISO228 1/2" NPT-M	316L	-

Table 7-9: Order information

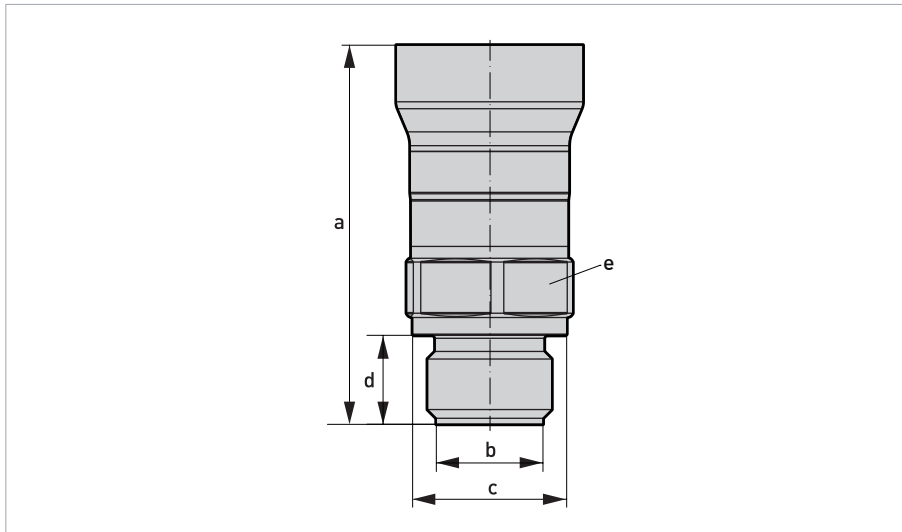

Figure 7-7: Thread ISO 228 / DIN 3852 front flush

Dimension	G1/2"		G1"	
	mm	inch	mm	inch
a	64	2.52	68	2.67
b	Ø 18	Ø 0.71	Ø 28	Ø 1.1
c	Ø 26	Ø 1.02	Ø 26	Ø 1.02
d	15	0.59	19	0.75
e	SW 27		SW 44	

Table 7-10: Dimension in mm / inch

Code	Designation	Material	Approvals
C3	Thread ISO228 G1/2" front-flush DIN3852	316L	-
C5	Thread ISO228 G1" front-flush DIN3852	316L	-

Table 7-11: Order information

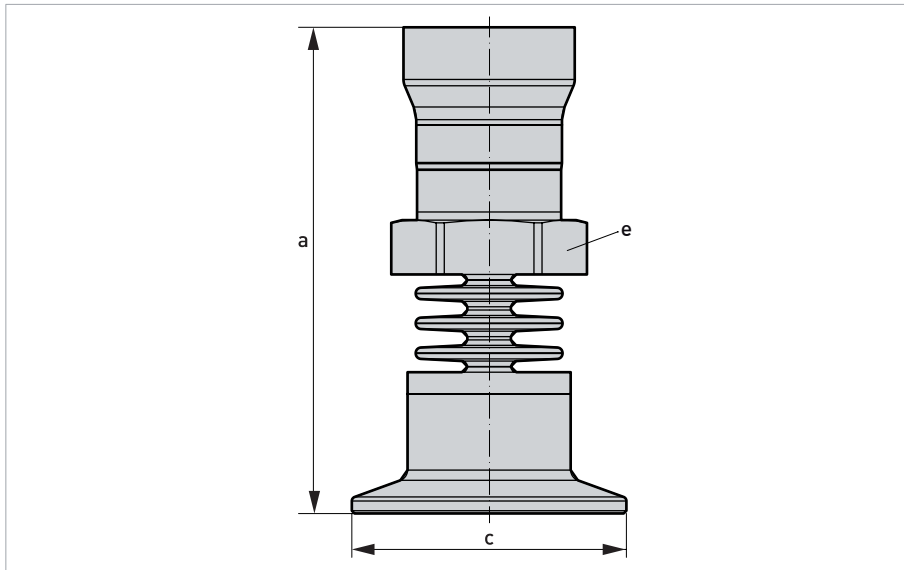

Figure 7-8: Clamp DIN 32676 / ISO 2852

Dimensions	DN25		DN40		DN50	
	mm	inch	mm	inch	mm	inch
a	89.5	3.52	89.5	3.52	89.5	3.52
c	Ø 50.5	Ø 1.99	Ø 50.5	Ø 1.99	Ø 64	Ø 2.52
e	SW 32		SW 32		SW 32	

Table 7-12: Dimension in mm / inch

Code	Designation	Pressure rating	Material	Approvals
AV	Clamp DN25 (1") ISO2852 / DIN32676	PN40	316L	3A, EHEDG
AT	Clamp DN38 (1 1/2") ISO2852 / DN40 DIN32676	PN40	316L	3A, EHEDG
AR	Clamp DN40-51 (2") ISO2852 / DN50 DIN32676	PN40	316L	3A, EHEDG

Table 7-13: Order information

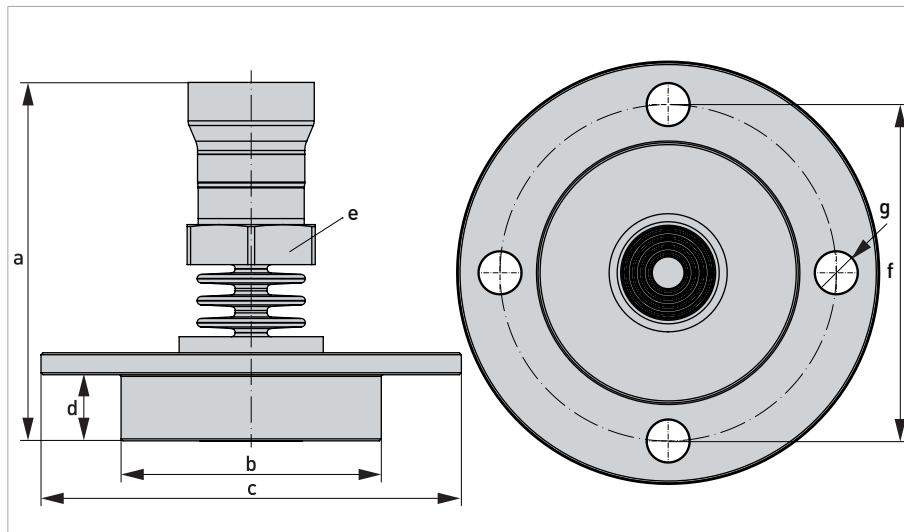

Figure 7-9: DRD flange

Dimension	DN65	
	mm	inch
a	89.5	3.52
b	Ø 65	Ø 2.56
c	Ø 105	Ø 4.13
d	16.5	0.65
e	SW 32	
f	Ø 84	Ø 3.31
g	4x Ø 10.5	Ø 0.41

Table 7-14: Dimension in mm / inch

Code	Designation	Pressure rating	Material	Approvals
AA	DRD DN50	PN40	316L	-

Table 7-15: Order information

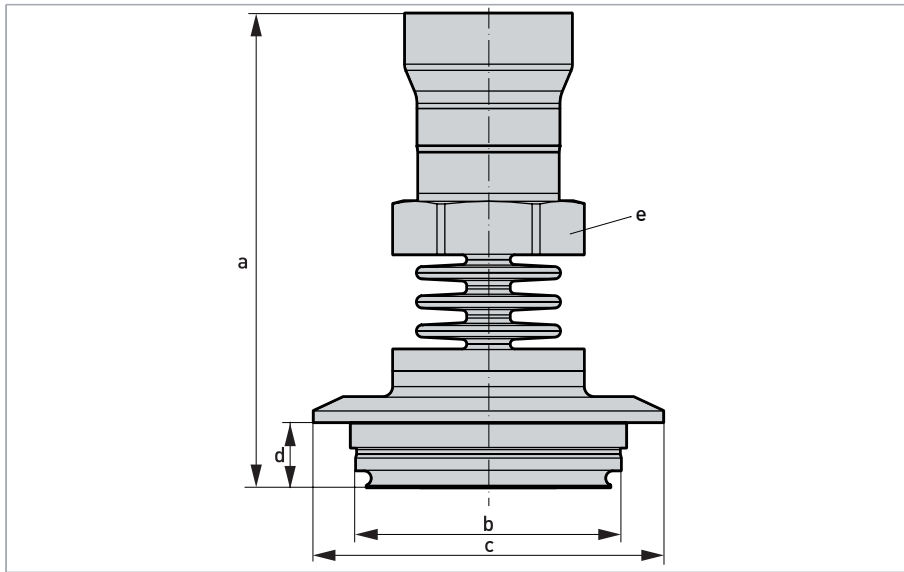

Figure 7-10: Varivent

Dimension	Varivent F		Varivent N	
	mm	inch	mm	inch
a	89.5	3.52	89.5	3.52
b	Ø 50	Ø 1.97	Ø 68	Ø 2.68
c	Ø 66	Ø 2.6	Ø 84	Ø 3.31
d	12.3	0.48	12.3	0.48
e	SW 32		SW 32	

Table 7-16: Dimension in mm / inch

Code	Designation	Pressure rating	Material	Approvals
FS	Varivent F DN25-32	PN40	316L	3A, EHEDG
FR	Varivent N DN40-162	PN40	316L	3A, EHEDG

Table 7-17: Order information

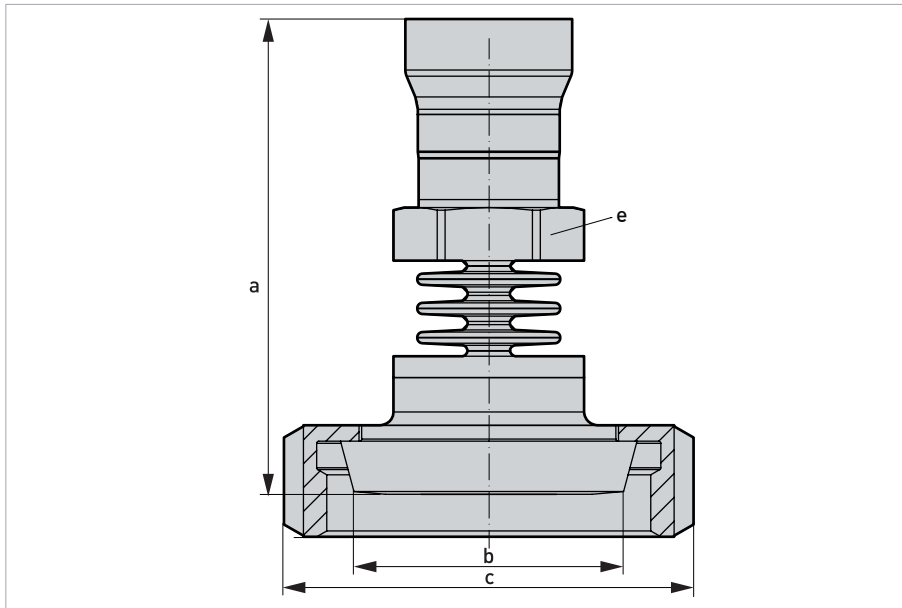

Figure 7-11: Collar connection DIN 11851

Dimension	DN25		DN40		DN50	
	mm	inch	mm	inch	mm	inch
a	89.5	3.52	89.5	3.52	89.5	3.52
b	Ø 38.9	Ø 1.53	Ø 50.9	Ø 2	Ø 62.9	Ø 2.48
c	Ø 63	Ø 2.48	Ø 78	Ø 3.07	Ø 92	Ø 3.62
e	SW 32		SW 32		SW 32	

Table 7-18: Dimension in mm / inch

Code	Designation	Pressure rating	Material	Approvals
E5	DIN11851 DN25	PN40	316L	3A, EHEDG
EZ	DIN11851 DN40	PN40	316L	3A, EHEDG
NB	DIN11851 DN50	PN25	316L	3A, EHEDG

Table 7-19: Order information

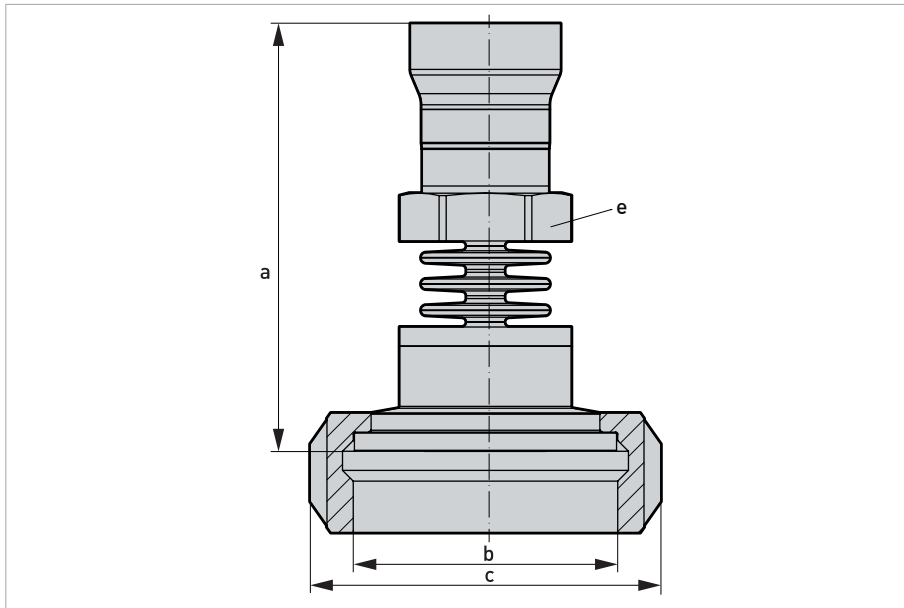

Figure 7-12: SMS SS1145

Dimension	1"		1 1/2"		2"	
	mm	inch	mm	inch	mm	inch
a	89.5	3.52	89.5	3.52	89.5	3.52
b	Ø 35.5	Ø 1.4	Ø 55	Ø 2.17	Ø 65	Ø 2.56
c	Ø 51	Ø 2.01	Ø 74	Ø 2.91	Ø 84	Ø 3.31
e	SW 32		SW 32		SW 32	

Table 7-20: Dimension in mm / inch

Code	Designation	Pressure rating	Material	Approvals
FC	SMS 1"	PN25	316L	-
FA	SMS 1 1/2"	PN25	316L	-
FB	SMS 2"	PN25	316L	-

Table 7-21: Order information

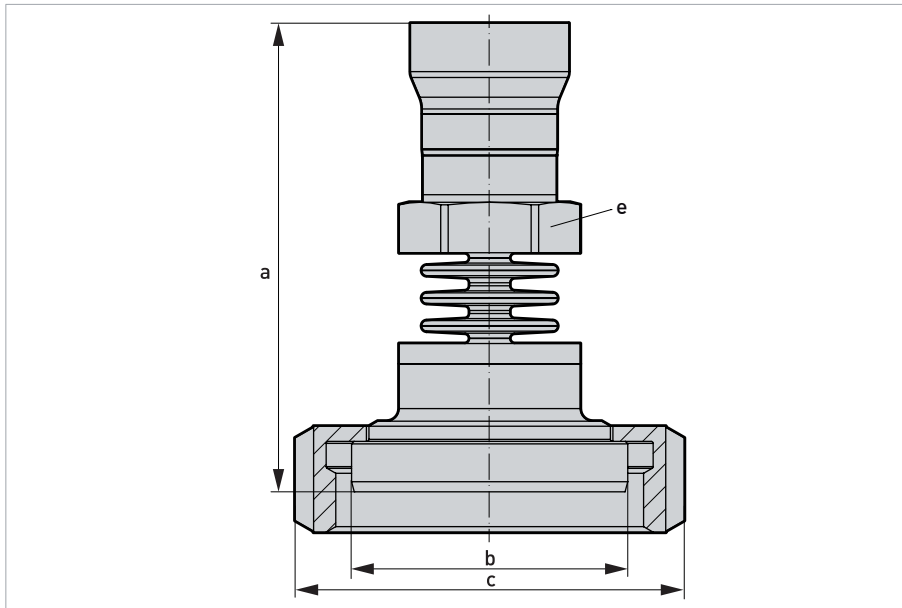

Figure 7-13: Collar connection DIN 11864-1 Form A

Dimension	DN25		DN40		DN50	
	mm	inch	mm	inch	mm	inch
a	93	3.66	93	3.66	93	3.66
b	Ø 42.9	Ø 1.69	Ø 54.9	Ø 2.16	Ø 66.9	Ø 2.63
c	Ø 63	Ø 2.48	Ø 78	Ø 3.07	Ø 92	Ø 3.62
e	SW 32		SW 32		SW 32	

Table 7-22: Dimension in mm / inch

Code	Designation	Pressure rating	Material	Approvals
V1	Collar Connection DIN11864-1 Form A	PN40	316L	3A, EHEDG
E2	Collar Connection DIN11864-1 Form A	PN40	316L	3A, EHEDG
E3	Collar Connection DIN11864-1 Form A	PN40	316L	3A, EHEDG

Table 7-23: Order information

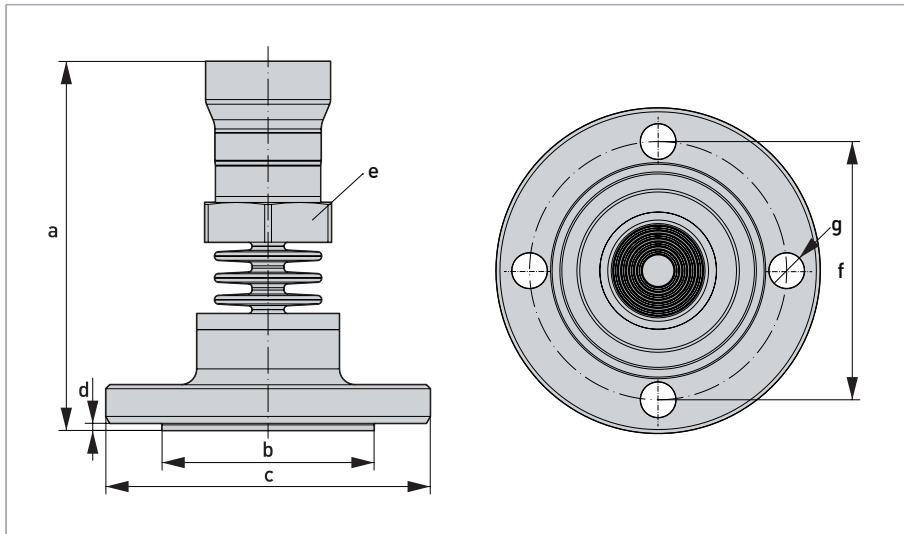

Figure 7-14: Collar flange DIN 11864-2 Form A

Dimension	DN40		DN50	
	mm	inch	mm	inch
a	93	3.66	93	3.66
b	Ø 53.6	Ø 2.11	Ø 65.6	Ø 2.58
c	Ø 82	Ø 3.23	Ø 94	Ø 3.7
d	1.8	0.07	1.8	0.07
e	SW 32		SW 32	
f	Ø 65	Ø 2.56	Ø 77	Ø 3.03
g	4x Ø 9	4x Ø 0.35	4x Ø 9	4x Ø 0.35

Table 7-24: Dimension in mm / inch

Code	Designation	Pressure rating	Material	Approvals
AC	Collar Flange DN40 DIN11864-2 Form A	PN25	316L	3A, EHEDG
AD	Collar Flange DN50 DIN11864-2 Form A	PN16	316L	3A, EHEDG

Table 7-25: Order information

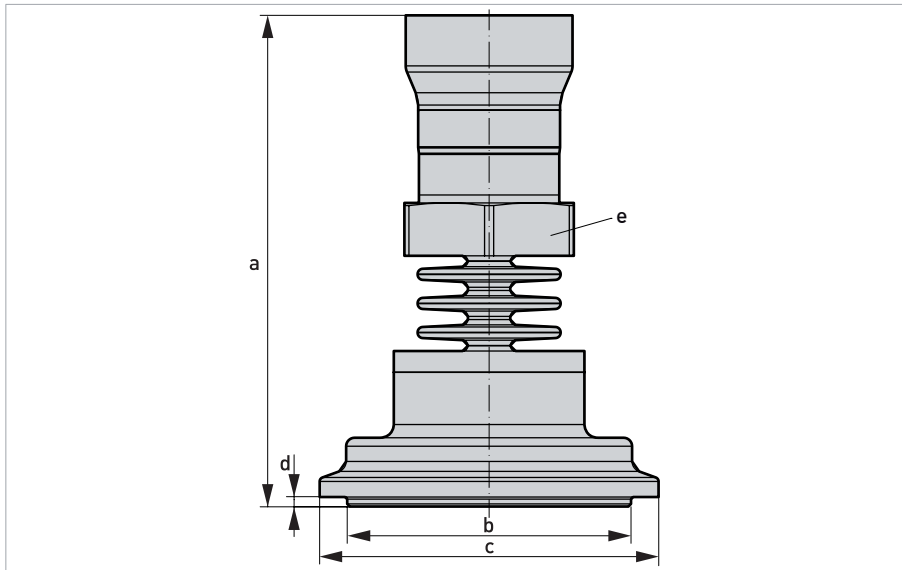

Figure 7-15: Collar clamp DIN 11864-3 Form A

Dimension	DN40		DN50	
	mm	inch	mm	inch
a	93	3.66	93	3.66
b	Ø 53.6	Ø 2.11	Ø 65.6	Ø 2.58
c	Ø 64	Ø 2.52	Ø 77.5	Ø 3.05
d	1.8	0.07	1.8	0.07
e	SW 32		SW 32	

Table 7-26: Dimension in mm / inch

Code	Designation	Pressure rating	Material	Approvals
TW	Collar clamp DN40 11864-3 Form A	PN25	316L	3A, EHEDG
T1	Collar clamp DN40 11864-3 Form A	PN25	316L	3A, EHEDG

Table 7-27: Order information

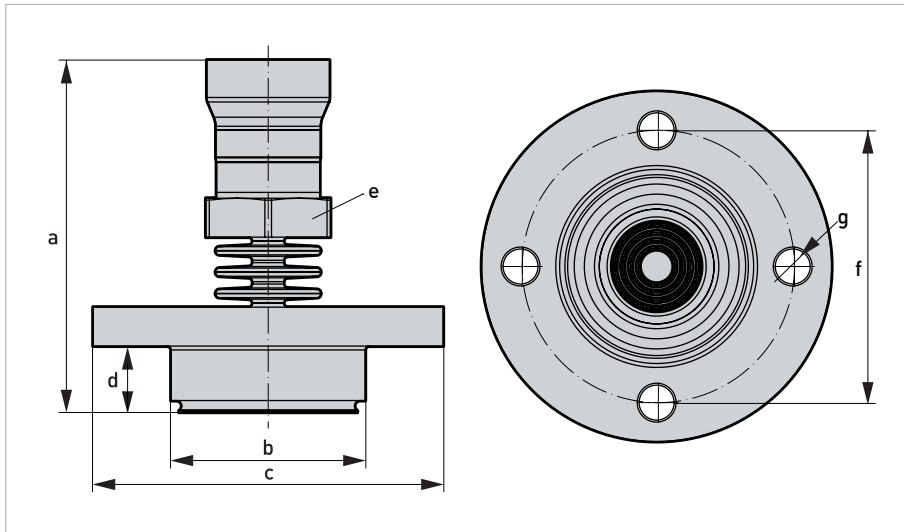

Figure 7-16: Neumo Biocontrol

Dimension	DN25		DN50		DN65	
	mm	inch	mm	inch	mm	inch
a	89.5	3.52	90.5	3.56	90.5	3.56
b	∅ 30.4	∅ 1.2	∅ 49.9	∅ 1.96	∅ 68	∅ 2.68
c	∅ 64	∅ 2.52	∅ 90	3.54	∅ 120	4.72
d	11	0.43	17	0.67	17	0.67
e	SW 32		SW 32		SW 32	
f	∅ 50	∅ 1.97	∅ 70	∅ 2.76	∅ 95	3.74
g	4x ∅ 7	4x ∅ 0.28	4x ∅ 9	4x ∅ 0.35	4x ∅ 11	4x ∅ 0.43

Table 7-28: Dimension in mm / inch

Code	Designation	Pressure rating	Material	Approvals
FG	NEUMO Biocontrol DN25	PN16	316L	3A, EHEDG
FD	NEUMO Biocontrol DN50	PN16	316L	3A, EHEDG
FE	NEUMO Biocontrol DN65	PN16	316L	3A, EHEDG

Table 7-29: Order information

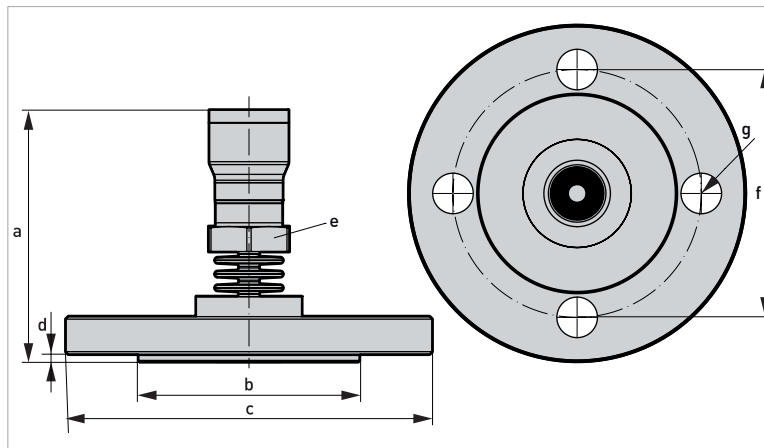

Figure 7-17: Flange EN1092-1 / DIN 2501

Dimension	DN25		DN40	
	mm	inch	mm	inch
a	100.5	3.96	100.5	3.96
b	Ø 68	Ø 2.68	Ø 80	Ø 3.15
c	Ø 115	Ø 4.53	Ø 150	Ø 5.91
d	2	0.08	3	0.12
e	SW 32		SW 32	
f	Ø 95	Ø 3.74	Ø 110	Ø 4.33
g	4x Ø 14	4x Ø 0.55	4x Ø 18	4x Ø 0.71

Table 7-30: Dimension in mm / inch

Dimension	DN50		DN80	
	mm	inch	mm	inch
a	100.5	3.96	100.5	3.96
b	Ø 102	Ø 4.02	Ø 138	Ø 5.43
c	Ø 165	Ø 6.5	Ø 200	Ø 7.87
d	3	0.12	3	0.12
e	SW 32		SW 32	
f	Ø 125	Ø 4.92	Ø 160	Ø 6.3
g	4x Ø 18	4x Ø 0.71	8x Ø 18	8x Ø 0.71

Table 7-31: Dimension in mm / inch

Code	Size	Nominal pressure	Form	Material	Approvals
N8	DN25	PN10-40	B1 (D)	316L	-
CR	DN40	PN10-40	B1 (D)	316L	-
CV	DN50	PN10-40	B1 (D)	316L	-
CH	DN80	PN10-40	B1 (D)	316L	-

Table 7-32: Order information

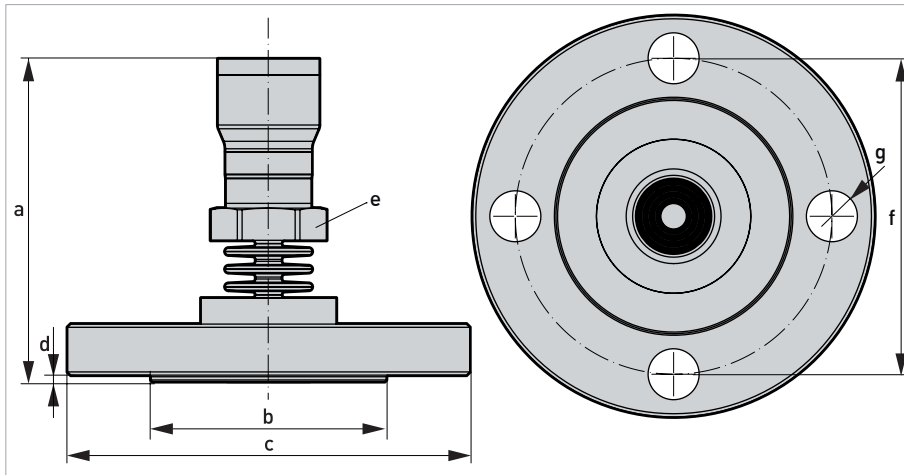

Figure 7-18: Flange ASME 16.5 (150 lbs)

Dimension	1"		1 1/2"	
	mm	inch	mm	inch
a	100.5	3.96	100.5	3.96
b	∅ 50.8	∅ 2	∅ 73.15	∅ 2.88
c	∅ 107.95	∅ 4.25	∅ 127	∅ 5
d	2	0.08	2	0.08
e	SW 32		SW 32	
f	∅ 79.25	∅ 3.12	∅ 98.55	∅ 3.88
g	4x ∅ 15.875	4x ∅ 0.625	4x ∅ 15.875	4x ∅ 0.625

Table 7-33: Dimension in mm / inch

Dimension	2"		3"	
	mm	inch	mm	inch
a	100.5	3.96	100.5	3.96
b	∅ 91.95	∅ 3.62	∅ 127	∅ 5
c	∅ 152.4	∅ 6	∅ 190.5	∅ 7.5
d	2	0.08	2	0.08
e	SW 32		SW 32	
f	∅ 120.65	∅ 4.75	∅ 152.4	∅ 6
g	4x ∅ 19.05	4x ∅ 0.75	4x ∅ 19.05	4x ∅ 0.75

Table 7-34: Dimension in mm / inch

Code	Size	Class	Form	Material	Approvals
BW	1"	150 lb	RF	316L	-
C1	1 1/2"	150 lb	RF	316L	-
CA	2"	150 lb	RF	316L	-
CB	3"	150 lb	RF	316L	-

Table 7-35: Order information

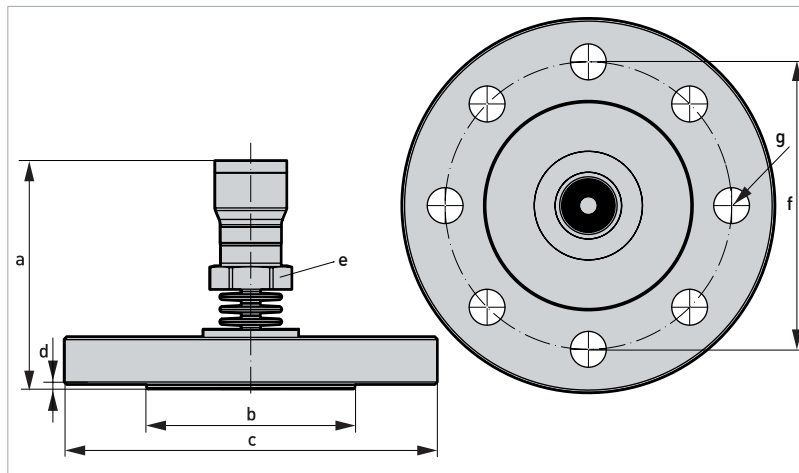

Figure 7-19: Flange ASME 16.5 (300 lbs)

Dimension	1"		2"	
	mm	inch	mm	inch
a	100.5	3.96	100.5	3.96
b	Ø 50.8	Ø 2	Ø 91.95	Ø 3.62
c	Ø 123.95	Ø 4.88	Ø 165.1	Ø 6.5
d	2	0.08	2	0.08
e	SW 32		SW 32	
f	Ø 88.9	Ø 3.5	Ø 127	Ø 5
g	4x Ø 19.05	4x Ø 0.75	8x Ø 19.05	8x Ø 0.75

Table 7-36: Dimension in mm / inch

Code	Size	Class	Form	Material	Approvals
Z3	1"	300 lb	RF	316L	-
BG	2"	300 lb	RF	316L	-

Table 7-37: Order information

7.5 Dynamic output behaviour

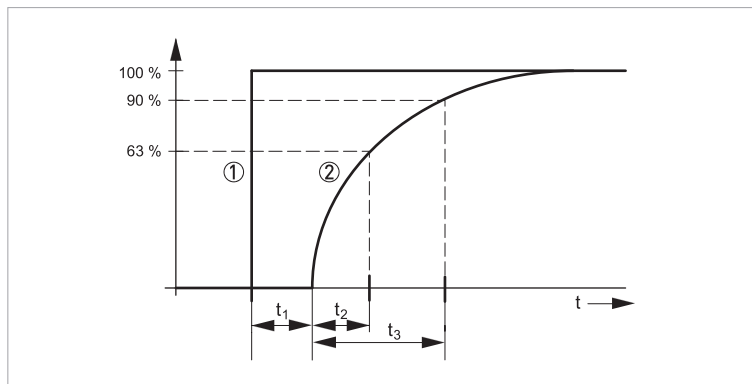

Figure 7-20: Behaviour at an abrupt change in the process variable.
 t_1 - dead time; t_2 - rise time t_{63} ; t_3 - rise time t_{90}

- ① Process variable
- ② Output signal

Analog Output with HART®

Dead time (t_1)	< 110 ms
Rise time T63 (t_2)	< 35 ms
Rise time T90 (t_3)	< 45 ms
Damping (63% of input variable)	1...30 seconds, adjustable

Analog Output with activated fast-mode

Dead time (t_1)	< 50 ms
Rise time T63 (t_2)	< 35 ms
Rise time T90 (t_3)	< 45 ms
Damping (63% of input variable)	0.1 seconds fixed value

These parameters depend on the fill fluid, temperature and, if applicable, the diaphragm seal.

8.1 General description

The open HART[®] protocol which can be used for free, is integrated into the signal converter for communication.

Devices which support the HART[®] protocol are classified as either operating devices or field devices. When it comes to operating devices (Master), both manual control units (Secondary Master) and PC-supported workstations (Primary Master) are used in, for example, a control centre.

HART[®] field devices include measuring sensors, signal converters and actuators. The field devices range from 2-wire to intrinsically safe versions for use in hazardous areas.

The HART[®] data are superimposed over the analogue 4...20 mA signal via FSK modem. This way, all of the connected devices can communicate digitally with one another via the HART[®] protocol while simultaneously transmitting the analogue signals.

When it comes to the field devices and secondary masters, the FSK or HART[®] modem is integrated. If a PC is used, an external modem must be connected to the serial interface (USB interface). There are, however, other connection variants which can be seen in the following connection figures.

8.2 Software history



INFORMATION!

In the table below, "x" is a placeholder for possible multi-digit alphanumeric combinations, depending on the available version.

Release date	SW version	HW version	HART [®]
			Device Revision
2018-01-01	1.0.x	1.0.x	1

Table 8-1: Overview software history

HART[®] identification codes and revision numbers

Manufacturer ID:	69 (0x45)
Device:	209 (0xD1)
Device Revision:	1
HART [®] Universal Revision:	7

Table 8-2: Overview identification codes and revision numbers

8.3 Connection variants

The signal converter is a 2-wire device with a passive 4...20 mA current output and a HART[®] interface.

- **Point-to-Point is supported**
In conventional point-to-point operation, the signal converter communicates as a slave with the master.
- **Multidrop mode is supported**
In a multidrop communication system, more than 2 devices are connected to a common transmission cable.
- **Burst Mode is not supported**
In the burst operation a slave device transfers cyclic pre-defined response telegrams, to get a higher rate of data transfer.

There are two ways of using the HART[®] communication:

- as Point-to-Point connection and
- as multidrop connection, with 2-wire connection.

8.4 Inputs/outputs and HART[®] dynamic variables and device variables

PV = Primary Variable; SV = Secondary Variable; TV = Tertiary Variable

HART [®] dynamic variable		
PV	SV	TV
Process pressure	Meas. cell temp.	Electronic temperature

Table 8-3: HART[®] output values acc. to HART[®] 7 (factory setting)

8.5 HART[®] commands

HART[®] universal commands

0	Read Unique Identifier
1	Read Primary Variable
2	Read Loop Current And Percent Of Range
3	Read Dynamic Variables And Loop Current
6	Write Polling Address
7	Read Loop Configuration
8	Read Dynamic Variable Classification
9	Read Device Variables With Status
11	Read Unique Identifier Associated With Tag
12	Read Message
13	Read Tag, Descriptor, Date
14	Read Primary Variable Transducer Information
15	Read Device Information
16	Read Final Assembly Number
17	Write Message
18	Write Tag, Descriptor, Date
19	Write Final Assembly Number
20	Read Long Tag
21	Read Unique Identifier Associated With Long Tag
22	Write Long Tag
38	Reset Configuration Changed Flag
48	Read Additional Device Status

Table 8-4: Overview universal commands

Common practice commands

33	Read Device Variable
34	Write Primary Variable Damping Value
35	Write Primary Variable Range Values
36	Set Primary Variable Upper Range Value
37	Set Primary Variable Lower Range Value
40	Enter/Exit Fixed Current Mode
42	Perform Device Reset
43	Set Primary Variable Zero
44	Write Primary Variable Units
45	Trim Loop Current Zero
46	Trim Loop Current Gain
50	Read Dynamic Variable Assignments
52	Set Device Variable Zero
53	Write Device Variable Units
59	Write Number Of Response Preambles
63	Read Analog Channel Information
79	Write Device Variable
80	Read Device Variable Trim Points
81	Read Device Variable Trim Guidelines
82	Write Device Variable Trim Point
83	Reset Device Variable Trim

Table 8-5: Overview common practice commands









KROHNE – Process instrumentation and measurement solutions

- Flow
- Level
- Temperature
- Pressure
- Process Analysis
- Services

Head Office KROHNE Messtechnik GmbH
Ludwig-Krohne-Str. 5
47058 Duisburg (Germany)
Tel.: +49 203 301 0
Fax: +49 203 301 10389
info@krohne.com

The current list of all KROHNE contacts and addresses can be found at:
www.krohne.com

KROHNE