



## MFC 400 Technical Datasheet

### Signal converter for mass flowmeters

- High performance signal converter for all applications, developed according to IEC 61508, SIL 2/3
- Stable in multi-phase applications due to Entrained Gas Management (EGM™)
- Smart diagnostics according to NAMUR NE 107



The documentation is only complete when used in combination with the relevant documentation for the flow sensor.

<b>1</b>	<b>Product features</b>	<b>3</b>
<hr/>		
1.1	The high performance signal converter for all applications .....	3
1.2	Options and variants .....	5
1.3	Signal converter / flow sensor combination possibilities.....	8
1.4	Measuring principle.....	8
<b>2</b>	<b>Technical data</b>	<b>9</b>
<hr/>		
2.1	Technical data.....	9
2.2	Dimensions and weight .....	21
2.2.1	Housing .....	21
2.2.2	Mounting plate of field housing .....	22
<b>3</b>	<b>Installation</b>	<b>23</b>
<hr/>		
3.1	Intended use .....	23
3.2	Installation specifications .....	23
3.3	Mounting of the compact version.....	23
3.4	Mounting the field housing, remote version .....	24
3.4.1	Pipe mounting .....	24
3.4.2	Wall mounting .....	25
<b>4</b>	<b>Electrical connections</b>	<b>26</b>
<hr/>		
4.1	Safety instructions.....	26
4.2	Connection diagram .....	26
4.3	Grounding the flow sensor .....	27
4.4	Connecting power - all housing variants .....	28
4.5	Inputs and outputs, overview .....	29
4.5.1	Combinations of the inputs/outputs (I/Os) .....	29
4.5.2	Description of the CG number .....	30
4.5.3	Fixed, non-alterable input/output versions.....	31
4.5.4	Alterable input/output versions.....	32
<b>5</b>	<b>Notes</b>	<b>33</b>
<hr/>		

## 1.1 The high performance signal converter for all applications

The **MFC 400** Coriolis mass flow signal converter will provide the highest performance possible across a wide range of applications. For the measurement of liquids or gases, cryogenic to high temperature fluids, single or multi-phase fluids and advanced digital signal processing techniques is used to give stable and accurate measurements of mass flow, density and temperature.

It is developed according to IEC 61508 and depending on the I/O and flow sensor variant suited for use in safety applications SIL 2/3.

Conforming to the NAMUR standard NE 107 for status and error handling, the MFC 400 features enhanced meter diagnostics. This provides extensive self-checking of internal circuits and information regarding the health of the flow sensor, but just as importantly, vital information about the process and process conditions.

Measuring values and diagnostic information can be transmitted via field bus interfaces including HART®, RS485 Modbus, FOUNDATION™ Fieldbus, PROFIBUS®, PROFINET IO and EtherNet/IP®.

Device commissioning, verification, diagnostics and monitoring can be transmitted via secure wireless Bluetooth® connection (<20 m / 65.6 ft) using the free download OPTICHECK Flow Mobile app for Google Android™ and Apple® iOS smartphone and tablet.



[signal converter in field housing]

- ① Supply voltage: 100...230 VAC (standard) and 24 VDC
- ② Communication with any third party system possible via HART®, Modbus, FOUNDATION™ Fieldbus, PROFIBUS®, PROFINET IO and EtherNet/IP®
- ③ Optional Bluetooth® connection (<20 m / 65.6 ft) possible
- ④ Intuitive navigation and a wide variety of languages integrated as standard for ease of operation



### EGM™ Entrained Gas Management

EGM™ was developed for the OPTIMASS Coriolis mass flowmeters to overcome problems caused by air or gas entrainments in a liquid. Powerful control algorithms maintain measurement, even during a complete transition from a pure liquid phase to a gas phase and back. Mass flow and density measurements remain stable and continuous, which has been demonstrated in batch / loading / empty-full-empty applications.

### Highlights

- High performance signal converter with multiple output options
- Developed according to IEC 61508
- Safe configuration via local display or HART®
- Partial proof test capable
- Smart diagnostics, covering entire devices in less than a minute
- NE 107 status indicated by display background light
- Entrained Gas Management (EGM™): meter maintains operation over a wide range of gas fractions and complex flow conditions
- Excellent long-term stability
- Optical and mechanical keys for ease of use
- Redundant data storage in signal converter housing
- Real time clock for logging events
- Overall, flexible lock concept
- HART® 7
- Communication interfaces for integration into third party systems via HART® (as standard), Modbus, FOUNDATION™ Fieldbus, PROFIBUS®, PROFINET IO and EtherNet/IP®
- Device commissioning, verification, diagnostics and monitoring can be transmitted via secure wireless Bluetooth® connection (<20 m / 65.6 ft)

### Industries

- Water & Wastewater
- Chemicals
- Food & Beverage
- Oil & Gas
- Petrochemical
- Pulp & Paper
- Pharmaceutical
- Marine

### Applications

- Liquids and gases
- Liquids with gas entrainment
- Slurries and viscous products
- Concentration measurement for quality control
- Measurement of volume flow
- Measurement of density and reference density
- Custody transfer loading/unloading
- Custody transfer measurements

## 1.2 Options and variants

### Compact design for standard applications



(Example: OPTIMASS 6400 – compact)



(Example: OPTIMASS 2400 – compact)

The MFC 400 mass flow signal converter is available in different variants and offers superior performance in any conceivable application. From process control in chemistry, to density and concentration measurements in the food and beverage industry, to custody transfer filling and transport measurements for oil and gas right down to conveyor systems in the pulp and paper industry.

Coriolis mass flow measuring systems measure the mass and volume flow, the density and the temperature of liquids and gases. In addition, the concentration in mixtures and slurries can also be determined.

Thanks to Entrained Gas Management (EGM™) the MFC 400 system maintains operation even with entrained gas of up to 100%.

For standard applications the compact housing is mounted directly on the flow sensor. In the unlikely event of a failure, the electronics can be easily exchanged and reconfigured using a backup data set that is stored in the housing.

### Remote field housing version



(signal converter in field housing)

The signal converter in the robust field housing is generally used when it is difficult to access the measuring point or when ambient conditions do not allow the use of the compact version.

Communication options

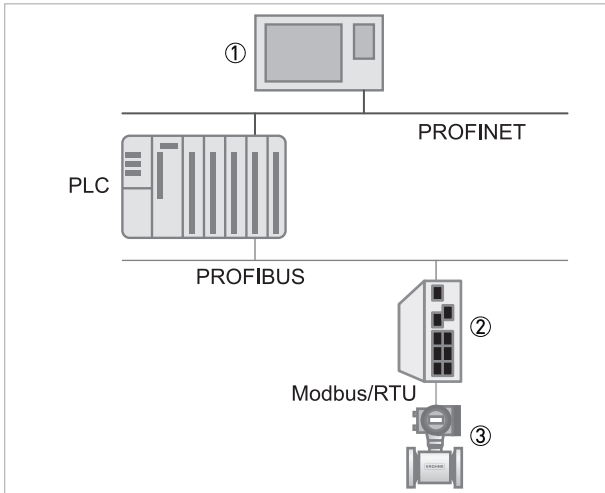

- ① Monitoring system
- ② Gateway
- ③ Flowmeter

The basic signal converter variant covers a current output including HART®, pulse/ frequency output, status output, control input and a current input.

The modular input/output variant allows for any combination of up to four inputs and outputs. All inputs and outputs are galvanically isolated from each other and from the rest of the electronic equipment. Inputs and outputs can be passive or active.

In addition, the electronics can be equipped with fieldbus functionality including Foundation Fieldbus, Profibus PA/DP, Modbus, PROFINET IO or EtherNet/IP® to enable communication to any third party system.

PROFINET IO or EtherNet/IP® option

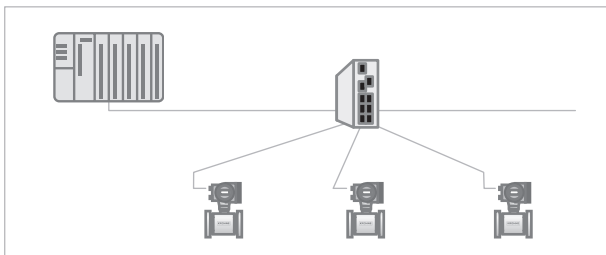

(1. point-to-point or star communication)

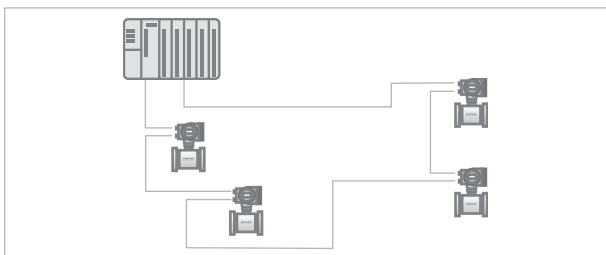

(2. ring or line communication)

With PROFINET IO or EtherNet/IP®, real time Ethernet can be connected to IoT scenarios.

The use of existing, legacy, industry-grade devices (e.g. PROFINET or EtherNet/IP® flow sensors, actuators and Programmable Logic Controllers (PLC's)) enables a new architecture to be used across the Internet.

An unique network topology:

1. Working with point-to-point or star communication using a single Ethernet port and an external switch.
2. Using ring or line communication there are two Ethernet ports available controlled by an internal switch.

## Bluetooth® option

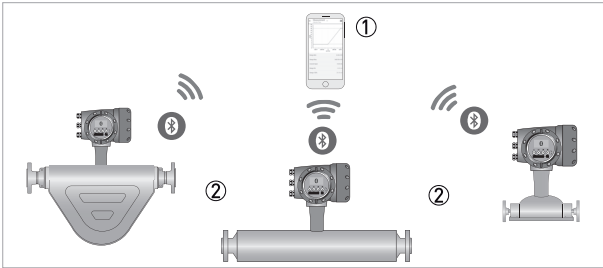

- ① Smartphone / tablet with OPTICHECK Flow Mobile app  
② Bluetooth® enabled flowmeter

With Bluetooth®, secure wireless communication (<20 m / 65.6 ft) with the device is possible using the free download OPTICHECK Flow Mobile app for Google Android™ and Apple® iOS smartphone and tablet.

Use in Ex zone 1 is possible with suitable devices.

Device commissioning, verification, diagnostics and monitoring are available without the need to remove the device from the line or interrupt the process.

Bluetooth® communication is available as an option at the time of ordering or as an add-on feature following delivery (option activated by password).

## Extensive diagnostics of the device and application

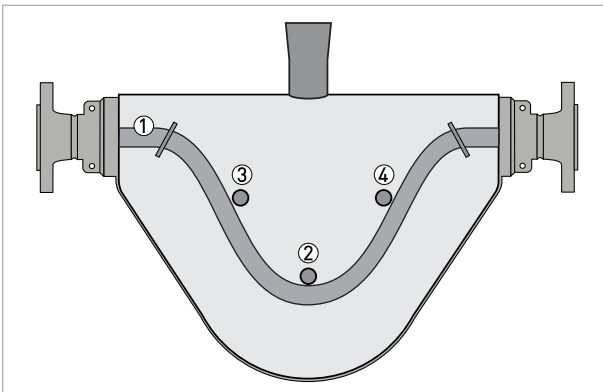

(Measuring principle (Twin tube))

- ① Measuring tubes  
② Drive coil  
③ Sensor 1  
④ Sensor 2

The primary focus of a user for a flowmeter is that it delivers reliable and robust measurements.

To achieve this all Coriolis mass flowmeters are calibrated before leaving the factory.

In addition, KROHNE was one of the first to introduce extensive diagnostic features.

The MFC 400 provides a wide range of diagnostic functions on the flow sensor, signal converter and process integrated in the signal converter.

Potential problems that may occur in the process including gas bubbles, solids, corrosion, deposits, empty pipe and partial filling of the flow sensor.

Diagnostic information available via local display, status outputs, fieldbuses, PACTware, xFC toolbox or the OPTICHECK.

## OPTICHECK Flow Mobile for on-site verification



OPTICHECK Flow Mobile provides internal verification using device diagnostics over secure wireless Bluetooth® communication.

The device snapshot function creates a file of measured values, diagnostics, device configuration and the event log to be emailed to the manufacturer specialists for analysis.

### OPTICHECK tool for on-site verification



(Suitcase with OPTICHECK and all cables and accessories)

The OPTICHECK provides an inline health check of the device under test by an external tool.

A hard copy of the verification report can be printed for every flowmeter. The verification data are digitally stored.

Contact us for more information or for an on-site service visit.

## 1.3 Signal converter / flow sensor combination possibilities

Flow sensor	Flow sensor + signal converter MFC 400	
	Compact version	Remote field housing version
OPTIMASS 1000	OPTIMASS 1400 C	OPTIMASS 1400 F
OPTIMASS 2000	OPTIMASS 2400 C	OPTIMASS 2400 F
OPTIMASS 3000	OPTIMASS 3400 C	OPTIMASS 3400 F
OPTIMASS 6000	OPTIMASS 6400 C	OPTIMASS 6400 F
OPTIMASS 7000	OPTIMASS 7400 C	OPTIMASS 7400 F

Table 1-1: Signal converter / flow sensor combination possibilities

## 1.4 Measuring principle

The signal converter has been designed to work with all the measuring tube designs used in the mass flowmeters. For information regarding the measuring principle for a specific measuring tube design, please refer to the technical documentation of the relevant flow sensor.



## 2.1 Technical data

- *The following data is provided for general applications. If you require data that is more relevant to your specific application, please contact us or your local sales office.*
- *Additional information (certificates, special tools, software,...) and complete product documentation can be downloaded free of charge from the website (Downloadcenter).*

### Measuring system

Measuring principle	Coriolis principle
Application range	Measurement of mass flow, density, temperature, volume flow, flow velocity, concentration

### Design

Modular construction	The measuring system consists of a flow sensor and a signal converter.
<b>Flow sensor</b>	
OPTIMASS 1000	DN15...50 / 1/2...2"
OPTIMASS 2000	DN100...400 / 4...16"
OPTIMASS 3000	DN01...04 / 1/25...4/25"
OPTIMASS 6000	DN08...250 / 3/8...10"
OPTIMASS 7000	DN06...80 / 1/4...3"
	All flow sensors are also available as Ex versions.
<b>Signal converter</b>	
Compact version (C)	OPTIMASS x400 C (x = 1, 2, 3, 6 or 7)
Field housing (F) - remote version	MFC 400 F
	Compact and field housing versions are also available in an Ex version.
<b>Options</b>	
Outputs / inputs	Current output (including HART®), pulse output, frequency output, and/or status output, limit switch and/or control input (depending on the I/O version)
Totaliser	2 (optional 3) internal totalisers with a max. of 8 counter places (e.g. for counting volume and/or mass units)
Verification	Integrated verification, diagnostic functions: measuring device, process, measured value, stabilisation
Concentration measurement	Universal concentration measurement, °Brix, °Baume, °Plato, alcohol concentration, NaOH and API density
Communication interfaces	HART®, Foundation Fieldbus, Profibus PA and DP, PROFINET IO, Modbus, Bluetooth® or EtherNet/IP®

<b>Display and user interface</b>	
Graphic display	LC display, backlit white.
	Size: 256 x 128 pixels, corresponds to 59 x 31 mm = 2.32" x 1.22"
	Display turnable in 90° steps.
	Ambient temperatures below -25°C / -13°F may affect the readability of the display.
Operating elements	4 push buttons/optical keys for operator control of the signal converter without opening the housing.
	Infrared interface for reading and writing all parameters with IR interface (option) without opening the housing.
Remote operation	PACTware™ (including Device Type Manager (DTM))
	HART® Handheld Communicator from Emerson Process
	AMS® from Emerson Process
	PDM® from Siemens
	All DTMs and drivers are available free of charge from the manufacturer's website.
	OPTICHECK Flow Mobile app via wireless Bluetooth® interface
<b>Display functions</b>	
Operating menu	Setting the parameters using 2 measuring pages, 1 status page, 1 graphic page (measured values and graphics are freely adjustable)
Language display texts	Available languages: English, German, French, Danish, Spanish, Italian, Dutch, Polish, Portuguese, Swedish, Turkish, Norwegian, Russian, Chinese
Measurement functions	<b>Units:</b> Metric, British and US units selectable as desired from lists for volume/mass flow and counting, velocity, temperature, pressure
	<b>Measured values:</b> Mass flow, total mass, temperature, density, volume flow, total volume, velocity, flow direction (not displayed unit – but available via outputs), Brix, Baume, NaOH, Plato, API, mass concentration, volume concentration
Diagnostic functions	<b>Standards:</b> VDI / NAMUR / WIB 2650 and NE 107
	<b>Status messages:</b> Output of status messages optional via display, current and/or status output, HART® or bus interface
	<b>Sensor and sensor electronics diagnosis:</b> Sensor signal integrity, sensor and drive coils diagnostics, measurement channels check, comparison of internal signals with references, drive circuit integrity, process temperature, CPU diagnostics, process temperature circuit monitoring, internal data integrity check, redundant calibration
	<b>Signal converter and inputs/outputs:</b> Data bus monitoring, current output connections, current readback with redundant calibration, factory calibration integrity, electronics temperature, CPU diagnostics, voltage monitoring

**Measuring accuracy**

Reference conditions	Medium: water
	Temperature: +20°C / +68°F
	Pressure: 1 bar / 14.5 psi
Maximum measuring error	Refer to the technical data of the flow sensor.

**Operating conditions**

<b>Temperature</b>	
Process temperature	Refer to the technical data of the flow sensor.
Ambient temperature	Depending on the version and combination of outputs.
	It is advised to protect the signal converter from external heat sources such as direct sunlight as higher temperatures reduce the life cycle of electronic components.
	<b>Die-cast aluminum housing:</b> SIL device: -40...+55°C / -40...+131°F Non-SIL device: -40...+65°C / -40...+149°F
	<b>Stainless steel housing:</b> SIL device: -40...+55°C / -40...+131°F Non-SIL device: -40...+60°C / -40...+140°F
	Ambient temperatures below -25°C / -13°F may affect the readability of the display.
Storage temperature	-40...+70°C / -40...+158°F
<b>Pressure</b>	
Medium	Refer to the technical data of the flow sensor.
Ambient pressure	Atmosphere: altitude up to 2000 m / 6561.7 ft above sea level
<b>Chemical properties</b>	
State of aggregation	Liquids, gases and slurries
Flow rate	Refer to the technical data of the flow sensor.
<b>Other conditions</b>	
Ingress protection according to IEC 60529	IP66/67 (according to NEMA 4/4X)

**Installation conditions**

Installation	For detailed information, refer to chapter "Installation".
Dimensions and weight	For detailed information refer to chapter "Dimensions and weight".

**Materials**

Signal converter housing	Standard: die-cast aluminum (polyurethane coated)
	Option: stainless steel 316 / 1.4408
Flow sensor	For housing material, process connections, measuring tubes, accessories and gaskets, refer to the technical data of the flow sensor.

**Electrical connection**

General	Electrical connection is carried out in conformity with the VDE 0100 directive "Regulations for electrical power installations with line voltages up to 1000 V" or equivalent national specifications.
Power supply	Standard: 100...230 VAC (-15% / +10%), 50/60 Hz
	Option: 24 VDC (-55% / +30%)
Power consumption	AC: 22 VA
	DC: 12 W
Signal cable	Only for remote versions.
	10 core shielded cable. Detailed specifications are available on request.
	Length: max. 20 m / 65.6 ft
Cable entries	Standard: M20 x 1.5 (8...12 mm)
	Option: 1/2 NPT, PF 1/2

## Inputs and outputs

General	All outputs are electrically isolated from each other and from all other circuits. All operating data and output values can be adjusted.	
Description of abbreviations	$V_{\text{ext}}$ = external voltage; $R_L$ = load + resistance; $V_0$ = terminal voltage; $I_{\text{nom}}$ = nominal current  Safety limit values [Ex i]: $V_i$ = max. input voltage; $I_i$ = max. input current; $P_i$ = max. input power rating; $C_i$ = max. input capacity; $L_i$ = max. input inductivity	
<b>Current output</b>		
Output data	Volume flow, mass flow, temperature, density, flow velocity, 2-phase signal, diagnostic values Concentration and concentration flow are also possible with available concentration measurement (optional).	
Resolution	<1 $\mu\text{A}$	
Uncertainty	$\pm 5 \mu\text{A}$	
Temperature coefficient	Typically $\pm 30 \text{ ppm/K}$	
Settings	<b>Without HART®</b> $Q = 0\%: 0 \dots 20 \text{ mA}; Q = 100\%: 10 \dots 20 \text{ mA}$ Alarm signal: selectable $0 \dots 22 \text{ mA}$  <b>With HART®</b> $Q = 0\%: 4 \dots 20 \text{ mA}; Q = 100\%: 10 \dots 20 \text{ mA}$ Alarm signal: selectable $3 \dots 22 \text{ mA}$	
Operating data	<b>Modular I/Os</b>	<b>Ex i</b>
Active	$V_{\text{int, nom}} = 24 \text{ VDC}$ $I \leq 22 \text{ mA}$ $R_L \leq 1 \text{ k}\Omega$	$V_{\text{int, nom}} = 21 \text{ VDC}$ $I \leq 22 \text{ mA}$ $R_L \leq 400 \Omega$  $I_0 = 90 \text{ mA}$ $P_0 = 0.5 \text{ W}$ $C_0 = 90 \text{ nF} / L_0 = 2 \text{ mH}$ $C_0 = 110 \text{ nF} / L_0 = 0.5 \text{ mH}$
Passive	$V_{\text{ext}} \leq 30 \text{ VDC}$ $I \leq 22 \text{ mA}$ $V_0 \geq 1.8 \text{ V}$ $R_L \leq (V_{\text{ext}} - V_0) / I_{\text{max}}$	$V_{\text{ext}} \leq 30 \text{ VDC}$ $I \leq 22 \text{ mA}$ $V_0 \geq 4 \text{ V}$ $R_L \leq (V_{\text{ext}} - V_0) / I_{\text{max}}$  $V_i = 30 \text{ V}$ $I_i = 130 \text{ mA}$ $P_i = 1 \text{ W}$ $C_i = 10 \text{ nF}$ $L_i \sim 0 \text{ mH}$

<b>HART®</b>		
Description	HART® protocol via active and passive current output	
	HART® version: V7	
	Universal HART® parameter: completely integrated	
Load	≥ 230 Ω at HART® test point; Note maximum load for current output!	
Multi-Drop operation	Disabled loop current mode, output current = 0%, e.g. 4 mA	
	Multi-Drop address adjustable in operation menu 0...63	
Device drivers	Available for FC 375/475, AMS, PDM, FDT/DTM	
Registration (HART Communication Foundation)	Yes	
<b>Pulse output or frequency output</b>		
Output data	Pulse output: volume flow, mass flow, mass or volume of dissolved substance during activated concentration measurement	
	Frequency output: flow velocity, mass flow, temperature, density, diagnostic value Optional: concentration, flow of the dissolved substance	
Function	Can be set as a pulse output or frequency output	
Pulse rate/frequency	0.01...10000 pulses/s or Hz (5000 Hz for phase-shifted or NAMUR outputs)	
Settings	Mass or volume per pulse or max. frequency for 100% flow	
	Pulse width: adjustable as automatic, symmetric or fixed (0.05...2000 ms)	
Operating data	<b>Modular I/Os</b>	<b>Fixed I/Os</b>
Active	$V_{nom} = 24 \text{ VDC}$	-
	$f_{max}$ in operating menu set to $f_{max} \leq 100 \text{ Hz}$ : $I \leq 20 \text{ mA}$	
	open: $I \leq 0.05 \text{ mA}$	
	closed: $V_{0, nom} = 24 \text{ V}$ at $I = 20 \text{ mA}$	
Active	$f_{max}$ in operating menu set to $100 \text{ Hz} <$ $f_{max} \leq 10 \text{ kHz}$ : $I \leq 20 \text{ mA}$	-
	open: $I \leq 0.05 \text{ mA}$	
	closed: $V_{0, nom} = 22.5 \text{ V}$ at $I = 1 \text{ mA}$ $V_{0, nom} = 21.5 \text{ V}$ at $I = 10 \text{ mA}$ $V_{0, nom} = 19 \text{ V}$ at $I = 20 \text{ mA}$	

Passive	$U_{\text{ext}} \leq 32 \text{ VDC}$	-
	$f_{\text{max}}$ in operating menu set to $f_{\text{max}} \leq 100 \text{ Hz}$ : $I \leq 100 \text{ mA}$  open: $I \leq 0.05 \text{ mA}$ at $V_{\text{ext}} = 32 \text{ VDC}$  closed: $V_{0, \text{max}} = 0.2 \text{ V}$ at $I \leq 10 \text{ mA}$ $V_{0, \text{max}} = 2 \text{ V}$ at $I \leq 100 \text{ mA}$	
	$f_{\text{max}}$ in operating menu set to $100 \text{ Hz} <$ $f_{\text{max}} \leq 10 \text{ kHz}$ : $I \leq 20 \text{ mA}$  open: $I \leq 0.05 \text{ mA}$ at $V_{\text{ext}} = 32 \text{ VDC}$  closed: $V_{0, \text{max}} = 1.5 \text{ V}$ at $I \leq 1 \text{ mA}$ $V_{0, \text{max}} = 2.5 \text{ V}$ at $I \leq 10 \text{ mA}$ $V_{0, \text{max}} = 5.0 \text{ V}$ at $I \leq 20 \text{ mA}$	
NAMUR	Passive to IEC 60947-5-6  $V_{\text{ext}} = 8.2 \text{ V} \pm 0.1 \text{ VDC}$ $R = 1 \text{ k}\Omega \pm 10 \Omega$  open: $I_{\text{nom}} = 0.6 \text{ mA}$  closed: $I_{\text{nom}} = 3.8 \text{ mA}$	Passive to IEC 60947-5-6  open: $I_{\text{nom}} = 0.43 \text{ mA}$  closed: $I_{\text{nom}} = 4.5 \text{ mA}$
		$V_i = 30 \text{ V}$ $I_i = 100 \text{ mA}$ $P_i = 1 \text{ W}$ $C_i = 10 \text{ nF}$ $L_i \sim 0 \text{ mH}$
<b>Low flow cut off</b>		
Function	Switching point and hysteresis separately adjustable for each output, counter and the display	
Switching point	Set in increments of 0.1%.	
	0...20% (current output, frequency output)	
Hysteresis	Set in increments of 0.1%.	
	0...20% (current output, frequency output)	
<b>Damping</b>		
Function	The time constant corresponds to the elapsed time until 63% of the end value has been reached according to a step function.	
Settings	Set in increments of 0.1 seconds.	
	0...100 seconds	

Status output / limit switch		
Function and settings	Adjustable as automatic measuring range conversion, display of flow direction, overflow, error or switching point.	
	Valve control with activated dosing function	
	Status and/or control: ON or OFF	
Operating data	Modular I/Os	Fixed I/Os
Active	$V_{\text{int}} = 24 \text{ VDC}$ $I \leq 20 \text{ mA}$  open: $I \leq 0.05 \text{ mA}$  closed: $V_{0, \text{nom}} = 24 \text{ V at } I = 20 \text{ mA}$	-
Passive	$V_{\text{ext}} \leq 32 \text{ VDC}$  $I \leq 100 \text{ mA}$  $R_{L, \text{max}} = 47 \text{ k}\Omega$ $R_{L, \text{min}} = (V_{\text{ext}} - V_0) / I_{\text{max}}$  open: $I \leq 0.05 \text{ mA at } V_{\text{ext}} = 32 \text{ VDC}$  closed: $V_{0, \text{max}} = 0.2 \text{ V at } I \leq 10 \text{ mA}$ $V_{0, \text{max}} = 2 \text{ V at } I \leq 100 \text{ mA}$	-
NAMUR	Passive to IEC 60947-5-6  $U_{\text{ext}} = 8.2 \text{ V} \pm 0.1 \text{ VDC}$ $R = 1 \text{ k}\Omega \pm 10 \Omega$  open: $I_{\text{nom}} = 0.6 \text{ mA}$ closed:  $I_{\text{nom}} = 3.8 \text{ mA}$	Passive to IEC 60947-5-6  open: $I_{\text{nom}} = 0.43 \text{ mA}$  closed: $I_{\text{nom}} = 4.5 \text{ mA}$  $V_i = 30 \text{ V}$ $I_i = 100 \text{ mA}$ $P_i = 1 \text{ W}$ $C_i = 10 \text{ nF}$ $L_i = 0 \text{ mH}$



Control input		
Function	Hold value of the outputs (e.g. for cleaning work), set value of the outputs to "zero", counter and error reset, stop counter, range conversion, zero calibration	
	Start of dosing when dosing function is activated.	
Operating data	<b>Modular I/Os</b>	<b>Fixed I/Os</b>
Active	$V_{int} = 24 \text{ VDC}$ External contact open: $V_{0, nom} = 22 \text{ V}$ External contact closed: $I_{nom} = 4 \text{ mA}$ Contact open (off): $V_0 \geq 12 \text{ V}$ with $I_{nom} = 1.9 \text{ mA}$ Contact closed (on): $V_0 \leq 10 \text{ V}$ with $I_{nom} = 1.9 \text{ mA}$	-
Passive	$3 \text{ V} \leq V_{ext} \leq 32 \text{ VDC}$ $I_{max} = 9.5 \text{ mA}$ at $V_{ext} \leq 24 \text{ V}$ $I_{max} = 9.5 \text{ mA}$ at $V_{ext} \leq 32 \text{ V}$ Contact closed (on): $V_0 \geq 3 \text{ V}$ with $I_{nom} = 1.9 \text{ mA}$ Contact open (off): $V_0 \leq 2.5 \text{ V}$ with $I_{nom} = 1.9 \text{ mA}$	$V_{ext} \leq 32 \text{ VDC}$ $I \leq 6 \text{ mA}$ at $V_{ext} = 24 \text{ V}$ $I \leq 6.5 \text{ mA}$ at $V_{ext} = 32 \text{ V}$ On: $V_0 \geq 5.5 \text{ V}$ with $I \geq 4 \text{ mA}$ Off: $V_0 \leq 3.5 \text{ V}$ with $I \leq 0.5 \text{ mA}$ $V_i = 30 \text{ V}$ $I_i = 100 \text{ mA}$ $P_i = 1 \text{ W}$ $C_i = 10 \text{ nF}$ $L_i = 0 \text{ mH}$
NAMUR	Active to IEC 60947-5-6 Terminals open: $V_{0, nom} = 8.7 \text{ V}$ Contact closed (on): $V_{0, nom} = 6.3 \text{ V}$ with $I_{nom} > 1.9 \text{ mA}$ Contact open (off): $V_{0, nom} = 6.3 \text{ V}$ with $I_{nom} < 1.9 \text{ mA}$ Detection of cable break: $V_0 \geq 8.1 \text{ V}$ with $I \leq 0.1 \text{ mA}$ Detection of cable short circuit: $V_0 \leq 1.2 \text{ V}$ with $I \geq 6.7 \text{ mA}$	-

<b>Profibus DP</b>	
Description	Galvanically isolated according to IEC 61158, test voltage 500 VAC RMS
	Profile version: 3.02
	Automatic data transmission rate recognition (max. 12 MBaud)
	Bus address adjustable via local display at the measuring device
Function blocks	8 x analogue input (AI), 3 x totaliser
Output data	Mass flow, volume flow, mass counter 1 + 2, volume counter, product temperature, several concentration measurements and diagnostic data
<b>Profibus PA</b>	
Description	Galvanically isolated according to IEC 61158, test voltage 600 VAC RMS for Ex i I/O, 500 VAC RMS for other I/O
	Profile version: 3.02
	Current consumption: 10.5 mA
	Permissible bus voltage: 9...32 V; in Ex application: 9...24 V
	Bus interface with integrated reverse polarity protection
	Typical error current FDE (Fault Disconnection Electronic): 4.3 mA
	Bus address adjustable via local display at the measuring device
Function blocks	8 x analogue input (AI), 3 x totaliser
Output data	Mass flow, volume flow, mass counter 1 + 2, volume counter, product temperature, several concentration measurements and diagnostic data
<b>Foundation Fieldbus</b>	
Description	Galvanically isolated according to IEC 61158, test voltage 600 VAC RMS for Ex i I/O, 500 VAC RMS for other I/O
	Current consumption: 10.5 mA
	Permissible bus voltage: 9...32 V; in Ex application: 9...24 V
	Bus interface with integrated reverse polarity protection
	Link Master function (LM) supported
	Tested with Interoperable Test Kit (ITK) version 6.01
Function blocks	6 x analogue input (AI), 2 x integrator, 1 x PID
Output data	Mass flow, volume flow, density, temperature of tube, several concentration measurements and diagnostic data
<b>Modbus</b>	
Description	Galvanically isolated, test voltage 500 VAC RMS
	Modbus RTU over RS-485
	Receiver input tolerance (baud rate deviation): 3%
	RS-485 receiver input resistance: 96 k $\Omega$ = 1/8 unit load
	RS-485 driver short-circuit output current: 200 mA
	Optionally switchable bus termination: 136 $\Omega$ , 0.5 W
	Optionally switchable bus polarisation: 2 x 562 $\Omega$ , 0.2 W
	Modbus device DTM is available which allows easy and comfortable communication with the signal converter.
Address range	1...255
Supported function codes	01, 02, 03, 04, 05, 06, 08, 15, 16, 23, 43
Baud rates	1200...115200

<b>PROFINET IO</b>	
Description	PROFINET IO is an Ethernet based communications protocol.
	The device features two Ethernet ports with an integrated industrial Ethernet switch.
	The Ethernet standard 100BASE-TX is supported.
	Additionally, the PHYs support the following features: - Auto negotiation - Auto crossover - Auto polarity
Output data	Mass flow, volume flow, flow speed, density, mass or volume counter 1 + 2, product temperature, several concentration measurements and diagnostic data
<b>EtherNet/IP®</b>	
Description	EtherNet/IP® is an Ethernet based communications protocol and part of the CIP (Common Industrial Protocol) network family standardised by ODVA..
	The device features two Ethernet ports with an integrated industrial Ethernet switch and supports beacon-based DLR as ring node.
	Integrated webserver allows remote configuration and monitoring of device status through standard browser software.
	Refer to the supplementary manual for a list of supported protocols and features.
Assembly data	Mass flow, volume flow, flow speed, density, mass or volume counter 1 + 2, product temperature, several concentration measurements and diagnostic data (depending on selected input assembly).
	Totaliser and zero calibration control in output assembly.
	Device parametrisation via configuration assembly.
<b>Bluetooth® interface</b>	
Description	The interface offers wireless connectivity to the device via Bluetooth® Low Energy 5.0.
	The used frequency range of Bluetooth® Low Energy is 2400...2480 MHz. The maximum output power of the device is 30 mW.
	OPTICHECK Flow Mobile app is available for Google Android™ and Apple® iOS mobile devices.
	Supported mobile devices must have at least the following features: - Bluetooth® Low Energy 4.0 interface or higher  For the minimal supported versions of Google Android™ or Apple® iOS refer to the latest version of the OPTICHECK Flow Mobile app available in "Google Play™ store" or "Apple App Store".
Functionality	Display status, measurement & diagnostic data
	Device parametrization and guided configuration wizards
	Advanced diagnostic methods
	Full device backup and restore

## Approvals and certificates

Declaration of conformity	This device fulfils the statutory requirements of the relevant directives. The manufacturer certifies successful testing of the product by applying the conformity mark.
	For full information of the directives and standards and the approved certifications, please refer to the declaration of conformity which is supplied with the device or download it from the website of the manufacturer.
Standard version	Non-Ex
Functional safety according to EN 61508	Depends on I/O variant and flow sensor. For detailed information refer to the "Safety manual".
<b>Hazardous areas</b>	
<b>Option (C version only)</b>	
ATEX	II 1/2 (1) G - Ex d ia [ia Ga] IIC T6 Ga/Gb
	II 1/2 (1) G - Ex de ia [ia Ga] IIC T6...T1 Ga/Gb
	II 2 (1) G - Ex d ia [ia Ga] IIC T6...T1 Gb
	II 2 (1) G - Ex de ia [ia Ga] IIC T6...T1 Gb
	II 2 (1) D - Ex t [ia Da] IIIC Txxx Db
	II 1/2 G - Ex d ia IIC T6...T1 Ga/Gb; II 1/2 G - Ex de ia IIC T6...T1 Ga/Gb
	II 2 G - Ex d ia IIC T6...T1 Gb; II 2 G - Ex de ia IIC T6...T1 Gb
	II 2 D - Ex t IIIC Txxx°C Db
<b>Option (F version only)</b>	
ATEX	II 2 (1) G - Ex db [ia Ga] IIC T6 Gb
	II 2 (1) G - Ex db eb [ia Ga] IIC T6 Gb
	II 2 (1) D - Ex tb [ia Da] IIIC T75°C Db
	II 2 G - Ex db eb [ia] IIC T6 Gb
	II 2 D - Ex tb IIIC T75°C Db
NEPSI	Ex d ia [ia Ga] IIC T6...T1 Ga/Gb; Ex de ia [ia Ga] IIC T6...T1 Ga/Gb
<b>Option</b>	
FM / CSA	FM: Class I, Div 1 groups A, B, C, D CSA: Class I, Div 1 groups C, D
	Class II, Div 1 groups E, F, G
	Class III, Div 1 hazardous areas
	FM: Class I, Div 2 groups A, B, C, D CSA: Class I, Div 2 groups C, D
	Class II, Div 2 groups E, F, G
	Class III, Div 2 hazardous areas
IECEx	Ex zone 1 + 2
<b>Custody transfer</b>	
Standard	Without
Option (in preparation)	Liquids other than water MID MI005 / OIML R117
	Gases MID MI002 / OIML R137
	Compliance with API and AGA
<b>Other standards and approvals</b>	
Vibration resistance	IEC 60068-2-6 10 cycles 10-150-10 Hz with: 0.15 mm for 10-60 Hz and 20 m/s <sup>2</sup> for 60-150 Hz
NAMUR	NE 21, NE 43, NE 53, NE 107

## 2.2 Dimensions and weight

### 2.2.1 Housing

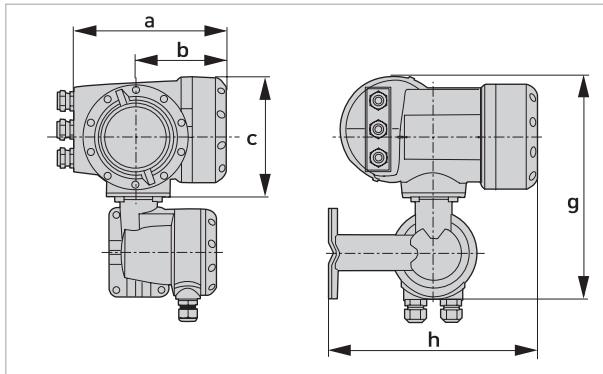

Figure 2-1: Dimensions for field housing (F) - remote version

Dimensions [mm / inch]					Weight [kg / lb]	
a	b	c	g	h	Aluminum housing	Stainless steel housing
202 / 7.95	120 / 4.72	155 / 6.10	296 / 11.65	277 / 10.90	6 / 13.2	13 / 28.7

Table 2-1: Dimensions and weight of field housing

*The total dimensions and weight of the compact device are depending on the nominal diameter and the material of the flow sensor.*

*For detailed information please refer to the relevant flow sensor documentation.*

### 2.2.2 Mounting plate of field housing

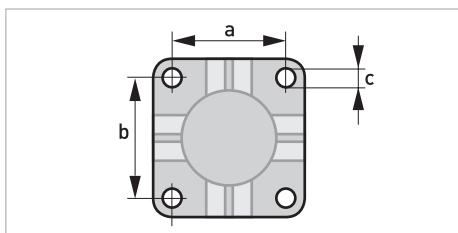

Figure 2-2: Dimensions for mounting plate of field housing

	[mm]	[inch]
a	72	2.8
b	72	2.8
c	Ø9	Ø0.4

Table 2-2: Dimensions in mm and inch

### 3.1 Intended use

The mass flowmeters are designed exclusively to directly measure mass flow rates, product density and temperature as well to indirectly measure parameters such as the total volume and concentration of dissolved substances as well as the volume flow rate.

*For devices used in hazardous areas, additional safety notes apply; please refer to the Ex documentation.*

*For devices used in SIL applications, additional safety notes apply. For detailed information refer to the "Safety manual".*

*If the device is not used according to the operating conditions (refer to chapter "Technical data"), the intended protection could be affected.*

*This equipment generates and radiates radio-frequency energy. In order to comply with ICNIRP radio-frequency radiation exposure limits for general public, this equipment has to be installed and operated while maintaining a minimum body to antenna distance of 0.2 m / 0.66 ft.*

*This device is a Group 1, Class A device as specified within CISPR11. It is intended for use in industrial environment. There may be potential difficulties in ensuring electromagnetic compatibility in other environments, due to conducted as well as radiated disturbances.*

### 3.2 Installation specifications

*The following precautions must be taken to ensure reliable installation.*

- *Make sure that there is adequate space to the sides.*
- *The device must not be heated by radiated heat (e.g. exposure to the sun) to an electronics housing surface temperature above the maximum permissible ambient temperature. If it is necessary to prevent damage from heat sources, a heat protection (e.g. sunshade) has to be installed.*
- *Signal converters installed in control cabinets require adequate cooling, e.g. by fan or heat exchanger.*
- *Do not expose the signal converter to intense vibrations. The measuring devices are tested for a vibration level as described in the chapter "Technical data".*

### 3.3 Mounting of the compact version

*Turning the housing of the compact version is not permitted.*

*The signal converter is mounted directly on the flow sensor. For installation of the flowmeter, please observe the instructions in the supplied product documentation for the flow sensor.*

### 3.4 Mounting the field housing, remote version

#### *Remarks for sanitary applications*

- *To prevent contamination and dirt deposits behind the mounting plate, a cover plug must be installed between the wall and the mounting plate.*
- *Pipe mounting is not suitable for sanitary applications!*

*Assembly materials and tools are not part of the delivery. Use the assembly materials and tools in compliance with the applicable occupational health and safety directives.*

#### 3.4.1 Pipe mounting

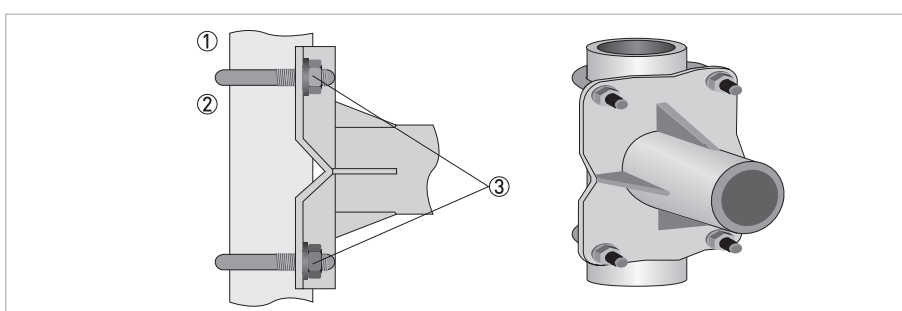

Figure 3-1: Pipe mounting of the field housing

- ① Fix the mounting bracket of the signal converter to the pipe.
- ② Fasten the mounting bracket of the signal converter using standard U-bolts and washers.
- ③ Tighten the nuts.



### 3.4.2 Wall mounting

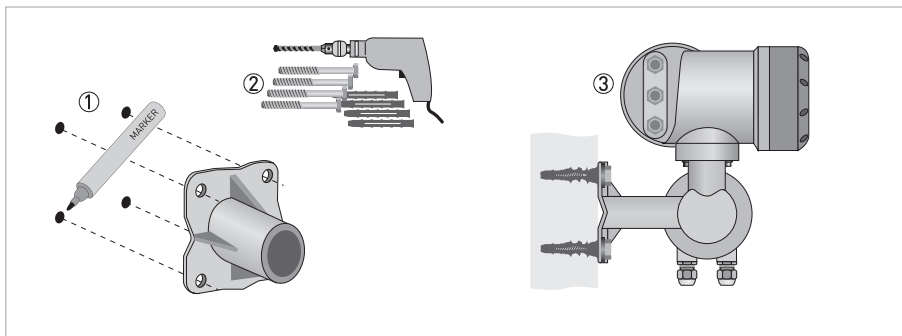

Figure 3-2: Wall mounting of the field housing

- ① Prepare the holes with the aid of the mounting plate. For further information refer to *Mounting plate of field housing* on page 22.
- ② Fasten the mounting plate securely to the wall.
- ③ Screw the mounting bracket of the signal converter to the mounting plate with the nuts and washers.

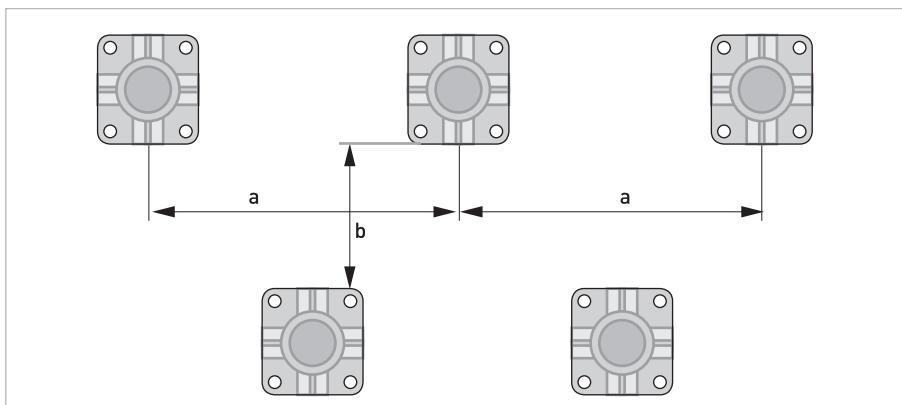

Figure 3-3: Mounting multiple devices next to each other

$a \geq 600 \text{ mm} / 23.6''$

$b \geq 250 \text{ mm} / 9.8''$

## 4.1 Safety instructions

*All work on the electrical connections may only be carried out with the power disconnected. Take note of the voltage data on the nameplate!*

*Observe the national regulations for electrical installations!*

*For devices used in hazardous areas, additional safety notes apply; please refer to the Ex documentation.*

*Observe without fail the local occupational health and safety regulations. Any work done on the electrical components of the measuring device may only be carried out by properly trained specialists.*

*Look at the device nameplate to ensure that the device is delivered according to your order. Check for the correct supply voltage printed on the nameplate.*

## 4.2 Connection diagram

*The device must be grounded in accordance with regulations in order to protect personnel against electric shocks.*

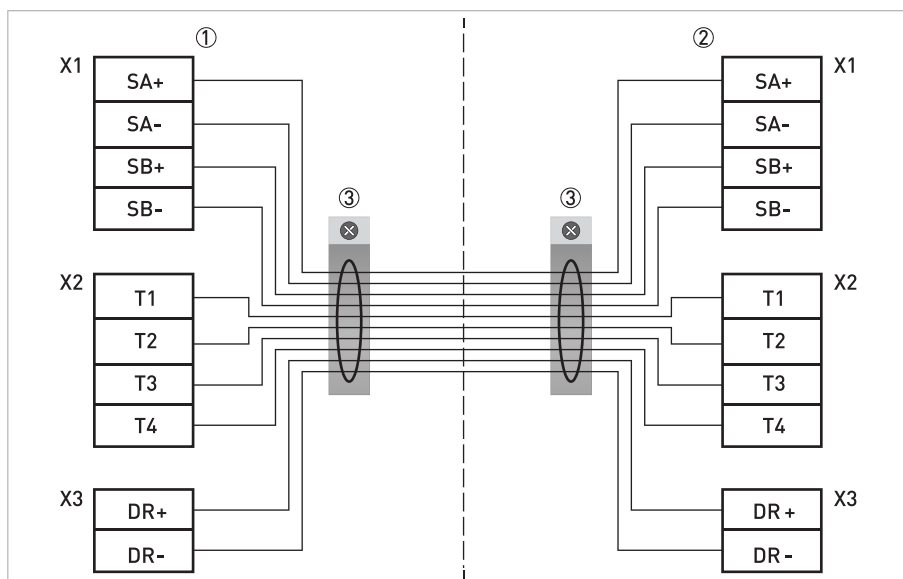

Figure 4-1: Connection diagram

- ① Terminal compartment for signal converter
- ② Terminal compartment for flow sensor
- ③ Connect shielding to spring terminal (drain wire and overall shield)

Cable		Connection terminal
Cable pair	Colour	
1	yellow	X1 SA+
1	black	X1 SA-
2	green	X1 SB+
2	black	X1 SB-
3	blue	X2 T1
3	black	X2 T2
4	red	X2 T3
4	black	X2 T4
5	white	X3 DR+
5	black	X3 DR-

Table 4-1: Colour coding of cables

### 4.3 Grounding the flow sensor

*There should be no difference in potential between the flow sensor and the housing or protective earth of the signal converter!*

- The flow sensor must be properly grounded.
- The grounding cable should not transmit any interference voltages.
- Do not use the grounding cable to connect more than one device to ground.
- The flow sensors are connected to ground by means of a functional grounding conductor FE.
- In hazardous areas, grounding is used at the same time for equipotential bonding. Additional grounding instructions are provided in the supplementary "Ex documentation", which are only supplied together with hazardous area equipment.

## 4.4 Connecting power - all housing variants

*The device must be grounded in accordance with regulations in order to protect personnel against electric shocks.*

*For devices used in hazardous areas, additional safety notes apply; please refer to the Ex documentation.*

- The protection category depends on the housing versions (IP66/67 or NEMA4/4X).
- The housings of the devices, which are designed to protect the electronic equipment from dust and moisture, should be kept well closed at all times. Creepage distances and clearances are dimensioned to VDE 0110 and IEC 60664 for pollution severity 2. Supply circuits are designed for overvoltage category III and the output circuits for overvoltage category II.
- Fuse protection ( $I_N \leq 16 \text{ A}$ ) for the infeed power circuit, as well as a separator (switch, circuit breaker) to isolate the signal converter must be provided close to the device. The separator must be marked as the separator for this device.

### 100...230 VAC (tolerance range: -15% / +10%)

- Note the power supply voltage and frequency (50...60 Hz) on the nameplate.
- The protective ground terminal **PE** of the power supply must be connected to the separate U-clamp terminal in the terminal compartment of the signal converter.

*240 VAC + 5% is included in the tolerance range.*

### 24 VDC (tolerance range: -55% / +30%)

- Note the data on the nameplate!
- For measurement process reasons, a functional ground **FE** must be connected to the separate U-clamp terminal in the terminal compartment of the signal converter.

*For 24 VDC, 12 VDC - 10% is included in the tolerance range.*

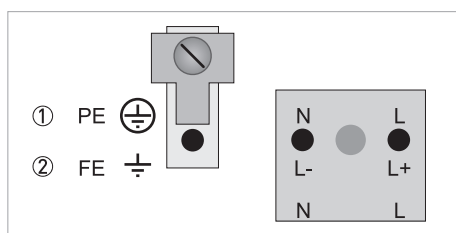

Figure 4-2: Power supply connection

- ① 100...230 VAC (-15% / +10%), 22 VA
- ② 24 VDC (-55% / +30%), 12 W

## 4.5 Inputs and outputs, overview

### 4.5.1 Combinations of the inputs/outputs (I/Os)

This signal converter is available with various input/output combinations.

#### Modular version

- Depending on the task, the device can be configured with various output modules.

#### Ex i version

- Depending on the task, the device can be configured with various output modules.
- Current outputs can be active or passive.
- Optionally available also with Foundation Fieldbus and Profibus PA.

#### Bus systems

- The device allows intrinsically safe and non-intrinsically safe bus interfaces in combination with additional modules.
- For connection and operation of bus systems, note the supplementary instructions.

#### Ex option

- For hazardous areas, all of the input/output variants for the housing designs C and F can be delivered with terminal compartment in Ex d (pressure-resistant casing) or Ex e (increased safety).
- For connection and operation of Ex devices, note the supplementary instructions.

## 4.5.2 Description of the CG number



Figure 4-3: Marking (CG number) of the electronics module and input/output variants

- ① ID number: 3
- ② ID number: 0 = standard
- ③ Power supply option
- ④ Display
- ⑤ Input/output version (I/O)
- ⑥ 1st optional module for connection terminal A
- ⑦ 2nd optional module for connection terminal B

The last 3 digits of the CG number (⑤, ⑥ and ⑦) indicate the assignment of the terminal connections.

Please refer to the following examples.

CG430114AC	100...230 VAC & standard display; modular I/O: $I_a$ & $P_N/S_N$ and optional module $I_a/S_N$ & $P_a/S_a$
CG43081200	24 VDC & standard display; Ex i I/O: $I_a$ & $P_a/S_a$ and optional module $I_a$ & $P_N/S_N/C_N$

Table 4-2: Examples for CG number

Abbreviation	Identifier for CG number	Description
$I_a$	A	Active current output
$I_p$	B	Passive current output
$P_a / S_a$	C	Active pulse output, frequency output, status output or limit switch (changeable)
$P_p / S_p$	E	Passive pulse output, frequency output, status output or limit switch (changeable)
$P_N / S_N$	F	Passive pulse output, frequency output, status output or limit switch according to NAMUR (changeable)
$C_a$	G	Active control input
$C_p$	K	Passive control input
$C_N$	H	Active control input according to NAMUR Signal converter monitors cable breaks and short circuits according to IEC 60947-5-6.
-	8	No additional module installed
-	0	No further module possible

Table 4-3: Description of abbreviations and CG identifier for possible optional modules on terminals A and B

### 4.5.3 Fixed, non-alterable input/output versions

This signal converter is available with various input/output combinations.

- The grey boxes in the tables denote unassigned or unused connection terminals.
- In the table, only the final digits of the CG no. are depicted.

CG no.	Connection terminals								
	A+	A	A-	B	B-	C	C-	D	D-

#### Ex i I/Os (option)

2 0 0						$I_a + \text{HART}^{\text{®}}$ active		$P_N / S_N$ NAMUR ①
3 0 0						$I_p + \text{HART}^{\text{®}}$ passive		$P_N / S_N$ NAMUR ①
2 1 0		$I_a$ active		$P_N / S_N$ NAMUR $C_p$ passive ①		$I_a + \text{HART}^{\text{®}}$ active		$P_N / S_N$ NAMUR ①
3 1 0		$I_a$ active		$P_N / S_N$ NAMUR $C_p$ passive ①		$I_p + \text{HART}^{\text{®}}$ passive		$P_N / S_N$ NAMUR ①
2 2 0		$I_p$ passive		$P_N / S_N$ NAMUR $C_p$ passive ①		$I_a + \text{HART}^{\text{®}}$ active		$P_N / S_N$ NAMUR ①
3 2 0		$I_p$ passive		$P_N / S_N$ NAMUR $C_p$ passive ①		$I_p + \text{HART}^{\text{®}}$ passive		$P_N / S_N$ NAMUR ①

#### PROFIBUS PA (Ex i) (option)

D 0 0						PA+	PA-	PA+	PA-
						FISCO Device		FISCO Device	
D 1 0		$I_a$ active		$P_N / S_N$ NAMUR $C_p$ passive ①		PA+	PA-	PA+	PA-
						FISCO Device		FISCO Device	
D 2 0		$I_p$ passive		$P_N / S_N$ NAMUR $C_p$ passive ①		PA+	PA-	PA+	PA-
						FISCO Device		FISCO Device	

#### FOUNDATION Fieldbus (Ex i) (option)

E 0 0						V/D+	V/D-	V/D+	V/D-
						FISCO Device		FISCO Device	
E 1 0		$I_a$ active		$P_N / S_N$ NAMUR $C_p$ passive ①		V/D+	V/D-	V/D+	V/D-
						FISCO Device		FISCO Device	
E 2 0		$I_p$ passive		$P_N / S_N$ NAMUR $C_p$ passive ①		V/D+	V/D-	V/D+	V/D-
						FISCO Device		FISCO Device	

#### PROFINET IO (option)

N 0 0		RX+	RX-	TX+	TX-	TX+	TX-	RX+	RX-
		Port 2				Port 1			

Table 4-4: Electrical connection of fixed, non-alterable input/output versions

① Changeable

#### 4.5.4 Alterable input/output versions

This signal converter is available with various input/output combinations.

- The grey boxes in the tables denote unassigned or unused connection terminals.
- In the table, only the final digits of the CG no. are depicted.
- Term. = (connection) terminal

CG no.	Connection terminals								
	A+	A	A-	B	B-	C	C-	D	D-

##### Modular I/Os (option)

4 __		max. 2 optional modules for term. A + B		I + HART® active/passive ①		P/S active/passive/ NAMUR ①
------	--	---	--	-------------------------------	--	--------------------------------

##### PROFIBUS PA (option)

D __		max. 2 optional modules for term. A + B		PA+ (2)	PA- (2)	PA+ (1)	PA- (1)
------	--	---	--	---------	---------	---------	---------

##### FOUNDATION Fieldbus (option)

E __		max. 2 optional modules for term. A + B		V/D+ (2)	V/D- (2)	V/D+ (1)	V/D- (1)
------	--	---	--	----------	----------	----------	----------

##### PROFIBUS DP (option)

F _ 0		1 optional module for term. A	Termina- tion P	RxD/TxD- P(2)	RxD/TxD- N(2)	Termina- tion N	RxD/TxD- P(1)	RxD/TxD- N(1)
-------	--	----------------------------------	--------------------	------------------	------------------	--------------------	------------------	------------------

##### Modbus (option)

G __ ②		max. 2 optional modules for term. A + B		Common		Sign. B (D1)	Sign. A (D0)
--------	--	---	--	--------	--	-----------------	-----------------

##### EtherNet/IP® (option)

M __	M12-connector; for pinning refer to EtherNet/IP® supplementary instructions						
------	---	--	--	--	--	--	--

Table 4-5: Electrical connection of alterable input/output versions

① Software configurable

② Bus termination and bus polarisation can be enabled/disabled by DIP switches









## KROHNE – Products, Solutions and Services

- Process instrumentation for flow, level, temperature, pressure measurement and process analytics
- Flow metering, monitoring, wireless and remote metering solutions
- Engineering, commissioning, calibration, maintenance and training services

Head Office KROHNE Messtechnik GmbH  
Ludwig-Krohne-Str. 5  
47058 Duisburg (Germany)  
Tel.: +49 203 301 0  
Fax: +49 203 301 10389  
info@krohne.de

The current list of all KROHNE contacts and addresses can be found at:  
[www.krohne.com](http://www.krohne.com)

