

OPTIMASS 7400 Technical Datasheet

Sensor for mass flow

- The optimum meter for demanding applications
- A single straight measuring tube
- Choice of 4 tube materials



The documentation is only complete when used in combination with the relevant documentation for the signal converter.

1	Product features	3
<hr/>		
1.1	Overview.....	3
1.2	Features and options.....	5
1.3	Meter / converter combinations.....	5
1.4	Measuring principle (single tube)	6
2	Technical data	8
<hr/>		
2.1	Technical data.....	8
2.1.1	ATEX (acc. 94/9/EC).....	12
2.1.2	ATEX (acc. 94/9/EC) temperature limits.....	12
2.2	Maximum end loadings	13
2.3	Measuring accuracy	14
2.4	Guidelines for maximum operating pressure.....	15
2.5	Dimensions and weights	20
2.5.1	Flanged versions.....	20
2.5.2	Hygienic versions	23
2.5.3	Heating jacket version	29
2.5.4	Purge port option	30
3	Installation	31
<hr/>		
3.1	Intended use	31
3.2	Mounting restrictions	31
3.2.1	General installation principles	31
3.2.2	Sunshades.....	33
4	Notes	34
<hr/>		

1.1 Overview

The OPTIMASS 7400 is the only sensor for mass flow with a single straight measuring tube that is available in Titanium, Stainless Steel, Hastelloy® or Tantalum.

Compact version

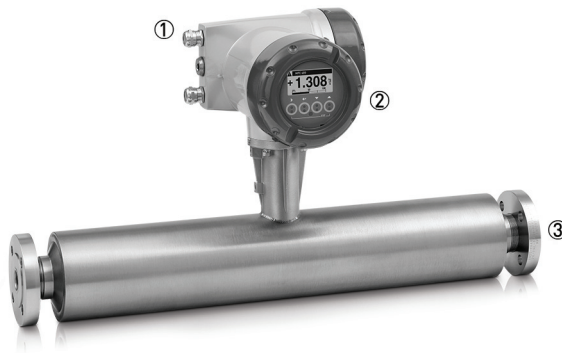

- ① Modular electronics with a range of output options (see separate documentation for details).
- ② The power of the MFC 400 gives comprehensive diagnostics together with Entrained Gas Management (EGM).
- ③ Available with a range of flange and hygienic connections.

Remote version



- ① Remote terminal box.

Highlights

- Outer cylinder typical burst pressure greater than 100 barg / 1450 psig, with optional PED approved secondary pressure containment available
- Easily drained and easy to clean
- Resistant to installation and process effects
- Excellent zero stability
- Low energy consumption, means lower operating costs
- Rapid signal processing, even with product / temperature changes
- Modular electronics with data redundancy - "plug & play" replacement of electronics

Industries

- Water & wastewater
- Mining & building materials
- Iron, steel and metal processing
- Food & beverage
- Oil, gas and alternative fuels
- Paper & pulp
- Petrochemical industry
- Pharmaceutical industry
- Chemical industry

Applications

- Viscous or shear-sensitive products
- Products requiring low flow velocities
- Non-homogeneous mixtures
- Products with entrained solids or gas
- Custody transfer
- Loading and product transfer measurement
- Slurries
- Highly corrosive fluids

1.2 Features and options

Features

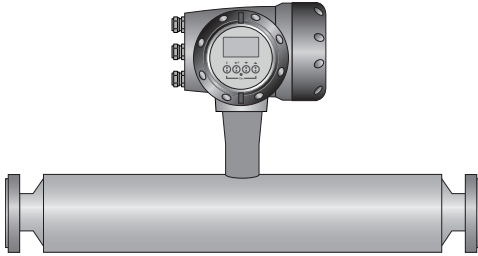

- Available as compact or remote.
- Low pressure loss - single straight tube design guarantees a low pressure drop across the meter.
- Self Draining.
- Easy to clean.
- With advanced Entrained Gas Management (EGM™) the meter maintains operation over a wide range of gas fractions and complex flow conditions.

Connection options

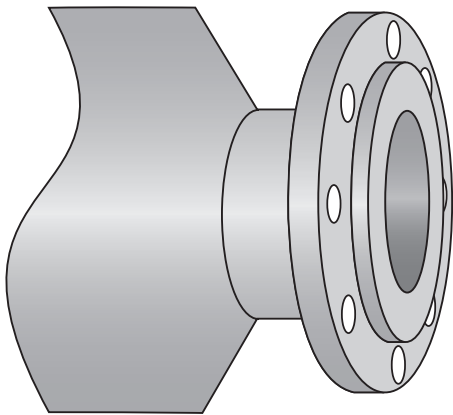

- A range of flanges up to ASME 600 / PN100.
- Supports a wide range of industry standard hygienic connections.
- Adaptable to suit customer's hygienic connections.

Heating jacket and purge port

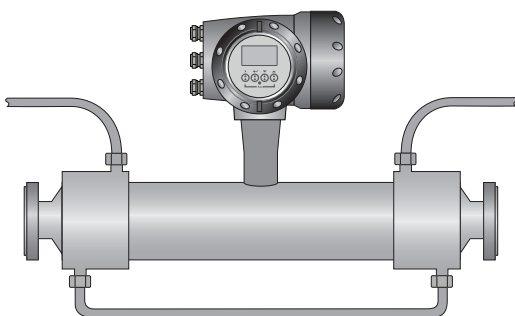

- Heating jacket option for use with temperature dependant products.
- Prevents solidification of process product.
- Purge port option for protection in the event of measuring tube failure.
- Allows hazardous chemicals to be drained away safely.
- Can also be used for the early detection of measuring tube failure where highly toxic chemicals are being measured.

1.3 Meter / converter combinations

Converter	MFC 400	
Configuration	Compact	Remote field
OPTIMASS 7400	7400C	7400F

1.4 Measuring principle (single tube)

Static meter not energised and with no flow

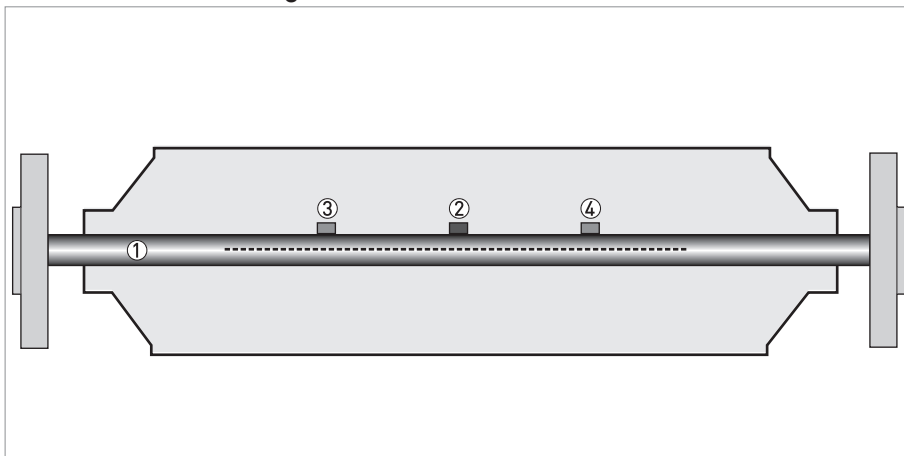

- ① Measuring tube
- ② Drive coil
- ③ Sensor 1
- ④ Sensor 2

A Coriolis single tube mass flowmeter consists of a single measuring tube ① a drive coil ② and two sensors (③ and ④) that are positioned either side of the drive coil.

Energised meter

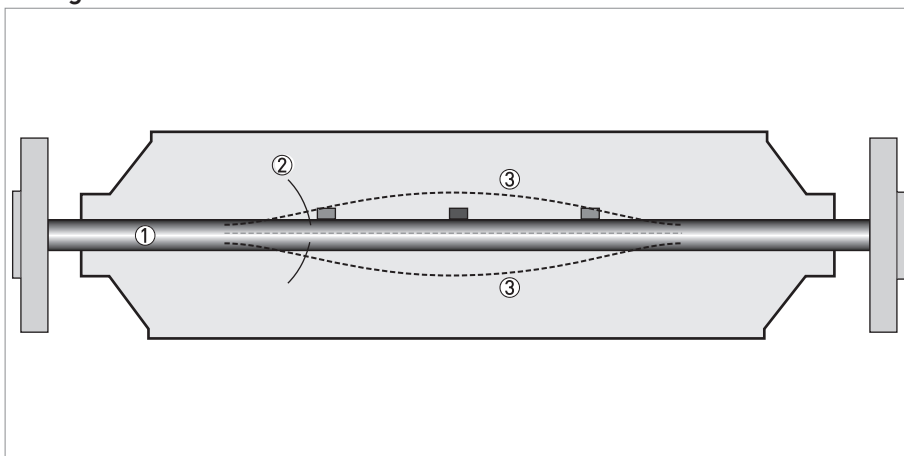

- ① Measuring tubes
- ② Direction of oscillation
- ③ Sine wave

When the meter is energised, the drive coil vibrates the measuring tube causing it to oscillate and produce a sine wave ③. The sine wave is monitored by the two sensors.

Energised meter with process flow

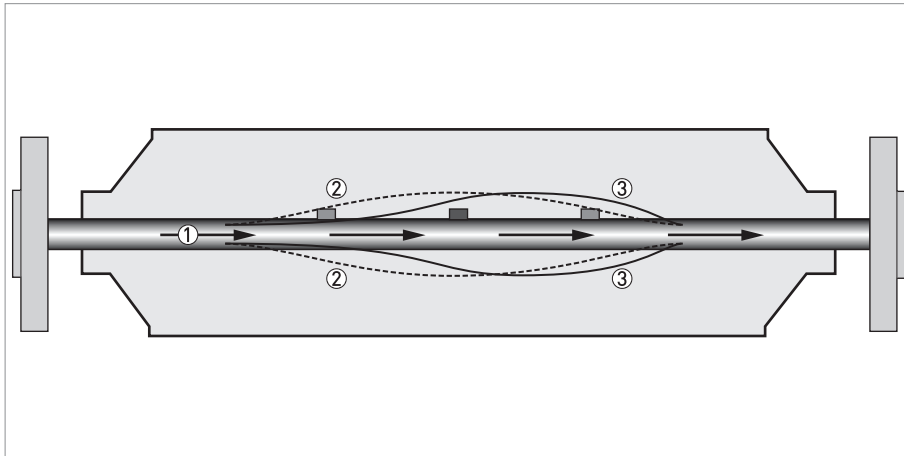

- ① Process flow
- ② Sine wave
- ③ Phase shift

When a fluid or gas passes through the tube, the coriolis effect causes a phase shift in the sine wave that is detected by the two sensors. This phase shift is directly proportional to the mass flow.

Density measurement is made by evaluation of the frequency of vibration and temperature measurement is made using a Pt500 sensor.

2.1 Technical data

- *The following data is provided for general applications. If you require data that is more relevant to your specific application, please contact us or your local sales office.*
- *Additional information (certificates, special tools, software,...) and complete product documentation can be downloaded free of charge from the website (Downloadcenter).*

Measuring system

Measuring principle	Coriolis mass flow
Application range	Mass flow and density measurement of fluids, gases and solids
Measured values	Mass, density, temperature
Calculated values	Volume, referred density, concentration, velocity

Design

Basic	System consists of a measuring sensor and a converter to process the output signal
Features	Fully welded maintenance free sensor with single straight measuring tube
Variants	
Compact version	Integral converter
Remote version	Available with field mount versions of the converter
Modbus version	Sensor with integral electronics providing Modbus output for connection to a PLC

Measuring accuracy

Mass	
Liquid	±0.1% of actual measured flow rate + zero stability
Gas	±0.35% of actual measured flow rate + zero stability
Zero stability	
Titanium	±0.004% of maximum flow rate with respective sensor size
Stainless Steel / Hastelloy® / Tantalum	±0.015% of maximum flow rate with respective sensor size
Reference conditions	
Product	Water
Temperature	+20°C / +68°F
Operating pressure	1 barg / 14.5 psig
Effect on sensor zero point caused by a shift in process temperature	
Titanium	0.001% per 1°C / 0.00055% per 1°F
Stainless Steel / Hastelloy® / Tantalum	0.004% per 1°C / 0.0022% per 1°F
Effect on sensor zero point caused by a shift in process pressure	
Titanium / Stainless Steel / Hastelloy® / Tantalum	0.0011% of the max flow rate per 1 bar _{rel.} / 0.000076% per 1 psig

Density	
Measuring range	400...2500 kg/m ³ / 25...155 lbs/ft ³
Accuracy	±2 kg/m ³ / ±0.13 lbs/ft ³
On site calibration	±0.5 kg/m ³ / ±0.033 lbs/ft ³
Temperature	
Accuracy	±1°C / ±1.8°F

Operating conditions

Maximum flow rates	
06	1230 kg/h / 45 lbs/min
10	3500 kg/h / 129 lbs/min
15	14600 kg/h / 536 lbs/min
25	44800 kg/h / 1646 lbs/min
40	120000 kg/h / 4409 lbs/min
50	234000 kg/h / 8598 lbs/min
80	560000 kg/h / 20567 lbs/min
Ambient temperature	
Compact version with Aluminium converter	-40...+60°C / -40...+140°F
	Extended temperature range +65°C / +149°F for some I/O options. For more information contact manufacturer
Compact version with Stainless Steel converter	-40...+55°C / -40...+130°F
Remote versions	-40...+65°C / -40...+149°F
Process temperature	
Titanium	-40...+150°C / -40...+302°F
Stainless Steel	0...+100°C / 32...+212°F
	Extended temperature range 0...+130°C / 32...+266°F on Stainless Steel, sizes 25...80, hygienic connections only
Hastelloy®	0...+100°C / 32...+212°F
Tantalum	0...+100°C / 32...+212°F
Nominal pressure at 20°C / 68°F	
Measuring tube	
Titanium	-1...100 barg / -14.5...1450 psig
Stainless Steel / Hastelloy® / Tantalum	-1...50 barg / -14.5...725 psig
Outer cylinder	
Non PED / CRN approved	Typical burst pressure > 100 barg / 1450 psig at 20°C
PED approved secondary containment	
Titanium (Stainless Steel 304 or 316 outer cylinder)	-1...63 barg / -14.5...910 psig
Titanium (Stainless Steel 316 outer cylinder)	-1...100 barg / -14.5...1450 psig
Stainless Steel / Hastelloy® (Stainless Steel 304 or 316 outer cylinder)	-1...63 barg / -14.5...910 psig
Tantalum (316 outer cylinder)	-1...50 barg / -14.5...725 psig

CRN approved secondary containment	
Titanium (Stainless Steel 304 or 316 outer cylinder)	-1...63 barg / -14.5...910 psig
Stainless Steel / Hastelloy® (Stainless Steel 304 or 316 outer cylinder)	-1...63 barg / -14.5...910 psig
Fluid properties	
Permissible physical condition	Liquids, gases, slurries
Permissible gas content (volume)	Contact manufacturer for information
Permissible solid content (volume)	Contact manufacturer for information
Other operating conditions	
Protection category (acc. to EN 60529)	IP 67, NEMA 4X

Installation conditions

Inlet runs	None required
Outlet runs	None required

Materials

Titanium meter	
Measuring tube / raised faces	Titanium grade 9 / grade 2
Flanges	Stainless Steel 316 / 316L (1.4401 / 1.4404) dual certified
Outer cylinder	Stainless Steel 304 / 304L (1.4301 / 1.4307) dual certified
	Optional Stainless Steel 316 / 316L (1.4401 / 1.4404) dual certified
Stainless Steel meter	
Measuring tube / raised faces	Stainless Steel UNS S31803 (1.4462)
	Measuring tube surface finish (Ra) ≤ 0.8 µm
Flanges	Stainless Steel 316 / 316L (1.4401 / 1.4404) dual certified
Outer cylinder	Stainless Steel 304 / 304L (1.4301 / 1.4307) dual certified
	Optional Stainless Steel 316 / 316L (1.4401 / 1.4404) dual certified
Hastelloy® meter	
Measuring tube / raised faces	Hastelloy® C-22
Flanges	Stainless Steel 316 / 316L (1.4401 / 1.4404) dual certified
Outer cylinder	Stainless Steel 304 / 304L (1.4301 / 1.4307) dual certified
	Optional Stainless Steel 316 / 316L (1.4401 / 1.4404) dual certified
Tantalum meter	
Measuring tube / raised faces	UNS R05255 / R05200
Flanges	Stainless Steel 316 / 316L (1.4401 / 1.4404) dual certified
Outer cylinder	Stainless Steel 316 / 316L (1.4401 / 1.4404) dual certified
Heating jacket version	
Heating jacket	Stainless Steel 316L (1.4404)
	The outer cylinder is in contact with the heating medium
All versions	
Sensor electronics housing	Stainless Steel 316L (1.4409)
Junction box (remote version)	Die cast Aluminium (polyurethane coating)
	Optional Stainless Steel 316L (1.4401)

Process connections

Flange	
DIN	DN10...100 / PN40...100
ASME	½...4" / ASME150...600
JIS	10...100A / 10...20K
Hygienic	
Tri-clover	½...4"
Tri-clamp DIN 32676	DN10...80
Tri-clamp ISO 2852	1½...4"
DIN 11864-2 form A	DN10...80
Male thread DIN 11851	DN10...80
Male thread SMS	1...3"
Male thread IDF / ISS	1...3"
Male thread RJT	1...3"

Electrical connections

Electrical connections	For full details, including power supply, power consumption etc., see technical data for the relevant converter
I/O	For full details of I/O options including data streams and protocols, see technical data for the relevant converter

Approvals and certifications

Mechanical	
Electromagnetic compatibility (EMC) acc. to CE	Namur NE 21/5.95
	2004/108/EC (EMC)
	2006/95/EC (Low Voltage Directive)
European Pressure Equipment Directive	PED 97-23 EC (acc. to AD 2000 Regelwerk)
Factory Mutual / CSA	Class I, Div 1 groups B, C, D
	Class II, Div 1 groups E, F, G
	Class III, Div 1 hazardous areas
	Class I, Div 2 groups B, C, D
	Class II, Div 2 groups F, G
ANSI / CSA (Dual Seal)	Class III, Div 2 hazardous areas
	12.27.901-2003
Hygienic	3A 28-03
	EHEDG
	ASME BPE
Custody transfer	MID 2004/22/EC MI-005
	OIML R117-1

2.1.1 ATEX (acc. 94/9/EC)

OPTIMASS 7000 / 7000F (with or without heating jacket / insulation)	
	II 1 G Ex ia IIC T6...T1 Ga
	II 1 D Ex ia IIIC T165°C Da
OPTIMASS 7400C Non Ex i signal outputs (with or without heating jacket / insulation)	
Ex d connection compartment	II 1/2 G Ex d ia IIC T6...T1 Ga/Gb
	II 2 D Ex tb IIIC T165°C Db
Ex e connection compartment	II 1/2 G Ex de ia IIC T6...T1 Ga/Gb
	II 2 D Ex tb IIIC T165°C Db
OPTIMASS 7400C Ex i signal outputs (with or without heating jacket / insulation)	
Ex d connection compartment	II 1/2(1) G Ex d ia [ia Ga] IIC T6...T1 Ga/Gb
	II 2(1) D Ex tb [ia Da] IIIC T165°C Db
Ex e connection compartment	II 1/2(1) G Ex de ia [ia Ga] IIC T6...T1 Ga/Gb
	II 2(1) D Ex tb [ia Da] IIIC T165°C Db

2.1.2 ATEX (acc. 94/9/EC) temperature limits

	Ambient temp. T _{amb} °C	Max medium temp. T _m °C	Temp. class	Max. surface temp. °C	
OPTIMASS 7000 / 7000F with or without heating jacket / insulation	40	40	T6	T55	
		70	T5	T85	
		90	T4	T105	
		150	T3 – T1	T165	
	50	70	T5	T85	
		90	T4	T105	
		150	T3 - T1	T165	
	65	90	T4	T105	
		130	T3 - T1	T145	
OPTIMASS 7400C with aluminium converter housing - with or without heating jacket / insulation	40	40	T6	T55	
		70	T5	T85	
		90	T4	T105	
		150	T3 – T1	T165	
	50	90	T4	T105	
		145	T3 – T1	T160	
	65	65	T6 – T1	T80	
	OPTIMASS 7400C with Stainless Steel converter housing - with or without heating jacket / insulation	40	40	T6	T55
			70	T5	T85
90			T4	T105	
130			T3 - T1	T145	
50		70	T5	T85	
		90	T4 - T1	T105	
60		60	T6 - T1	T75	

2.2 Maximum end loadings

Maximum end loadings

Size	06	10	15	25	40	50	80
Titanium							
Flanges	19kN	25kN	38kN	60kN	80kN	170kN	230kN
Hygienic (welded)	1.5kN	2kN	5kN	9kN	12kN	12kN	30kN
Hygienic (adaptor)	1.5kN	1.8kN	3.3kN	3.8kN	2.2kN	5.8kN	9.6kN
Stainless Steel / Hastelloy® / Tantalum							
Flanges	19kN	25kN	38kN	60kN	80kN	80kN	170kN
Hygienic (welded)	1.5kN	2kN	5kN	9kN	12kN	12kN	18kN
Hygienic (adaptor)	1.5kN	1.8kN	3.3kN	3.8kN	2.2kN	5.8kN	9.6kN

- These (axial) loads have been calculated, based on 316L schedule 40 process pipework, where un-radiographed butt welds have been used in pipe joints.
- The loads shown are the maximum permitted static load. If loads are cycling (between tension and compression) these loads should be reduced. For advice, consult the manufacturer.

The maximum permitted end loading on size 15 meters fitted with ½" ASME flanges is 19kN

2.3 Measuring accuracy

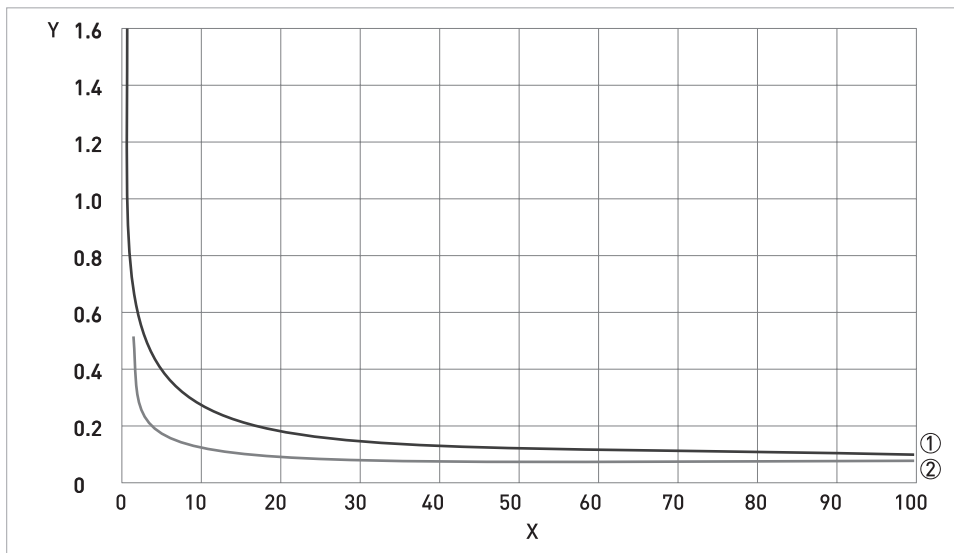

X flow rate [%]
 Y measuring error [%]

- ① Stainless Steel, Hastelloy® and Tantalum
- ② Titanium

Measuring error

The measuring error is obtained from the combined effects of accuracy and zero stability.

Reference conditions

Product	Water
Temperature	+20°C / +68°F
Operating pressure	1 barg / 14.5 psig

2.4 Guidelines for maximum operating pressure

Notes

- Ensure that the meter is used within its operating limits
- Adapter type hygienic process connections have a maximum operating rating of 10 barg at 150°C / 145 psig at 302°F

Pressure / temperature de-rating for Titanium Gr 9 meters (all meter sizes, with flanged connections as per EN 1092-1 and JIS B 2220)

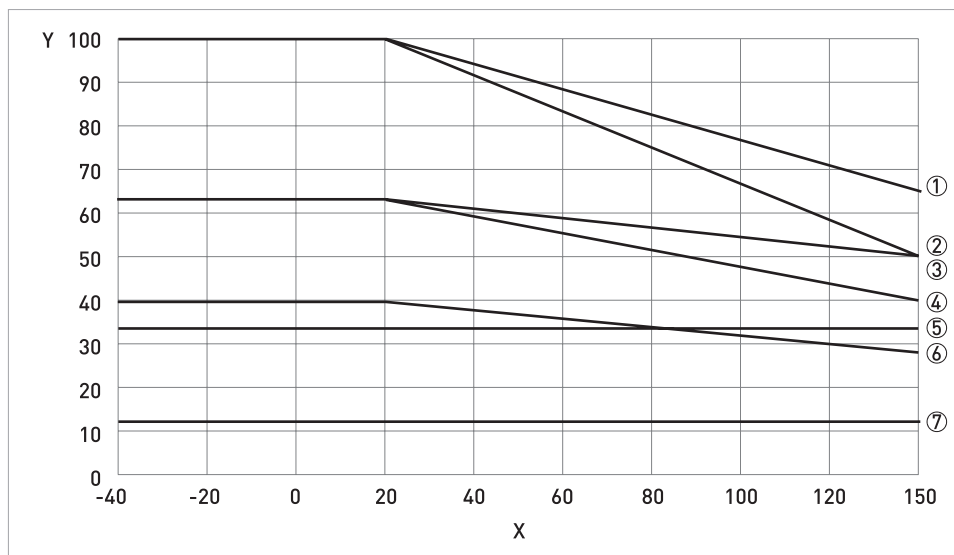

X temperature [°C]

Y pressure [barg]

- ① Standard tube and outer cylinder 316L (100 barg PED option) with PN100 flanges (sizes DN06...25)
- ② Standard tube and outer cylinder 316L (100 barg PED option) with PN100 flanges (sizes DN40...80)
- ③ DIN 2637 PN63 flanges
- ④ Outer cylinder (63 barg PED / CRN option)
- ⑤ JIS 20K flanges
- ⑥ DIN 2635 PN40 flanges
- ⑦ JIS 10K flanges

**Pressure / temperature de-rating for Titanium Gr 9 meters
(all meter sizes with flanged connections as per ASME B16.5)**

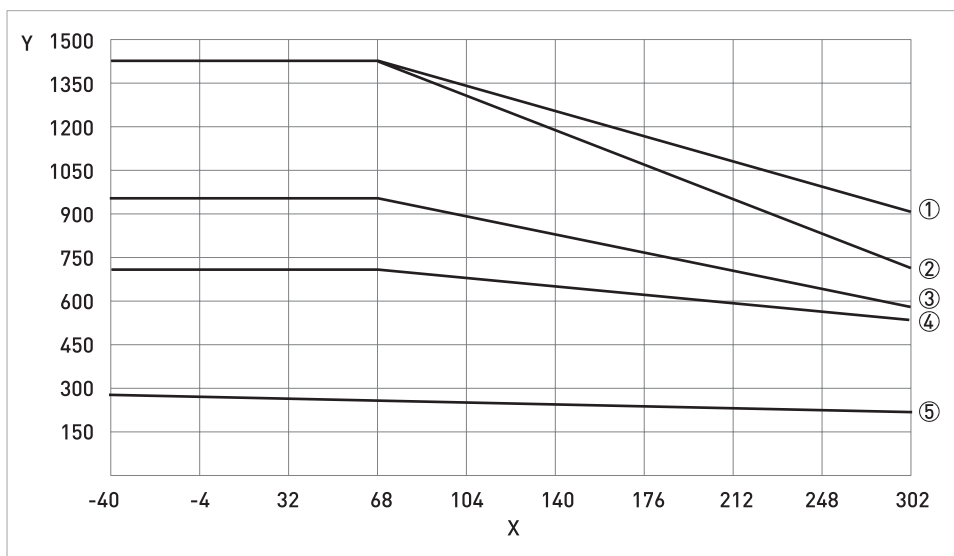

X temperature [°F]
Y pressure [psig]

- ① Standard tube and outer cylinder 316L (100 barg PED option) with ASME 600 lbs flanges (sizes DN06...25)
- ② Standard tube and outer cylinder 316L (100 barg PED option) with ASME 600 lbs flanges (sizes DN40...80)
- ③ Outer cylinder (63 barg PED / CRN option)
- ④ ASME 300 lbs
- ⑤ ASME 150 lbs

Pressure / temperature de-rating for Stainless Steel, Hastelloy® C22 and Tantalum meters (all meter sizes with flanged connections as per EN 1092-1 and JIS B 2220)

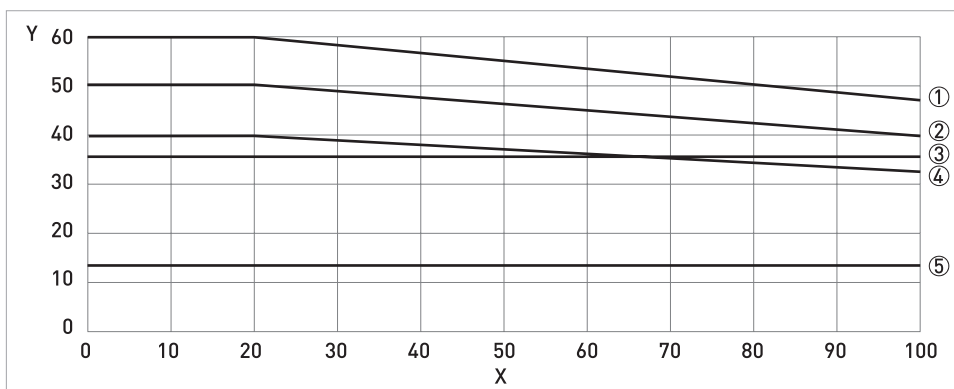

X temperature [°C]
Y pressure [barg]

- ① Outer cylinder de-rating for SS and Hastelloy® meters, all sizes. (63 barg PED / CRN option)
- ② De-rating for SS, Hastelloy® and Tantalum measuring tubes and outer cylinder de-rating for Tantalum meters (all sizes).
- ③ JIS 20K flanges
- ④ DIN 2635 PN40 flanges
- ⑤ JIS 10K flanges

Pressure / temperature de-rating for Stainless Steel, Hastelloy® C22 and Tantalum meters (all meters with flanged connections as per ASME B16.5)

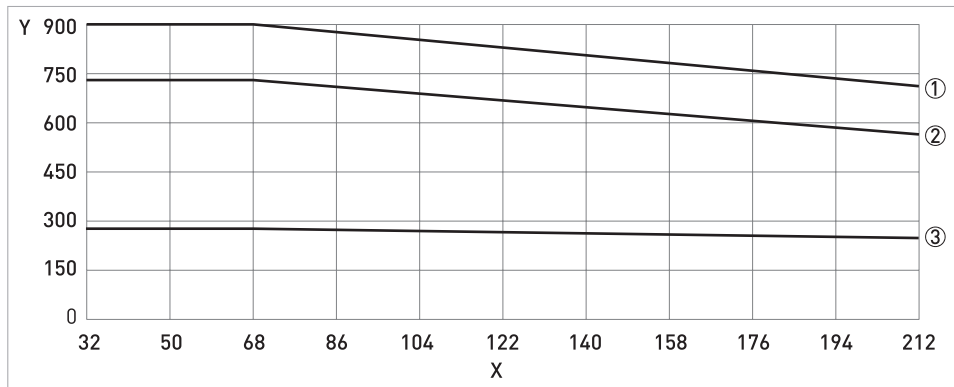

X temperature [°F]

Y pressure [psig]

- ① Outer cylinder de-rating for SS and Hastelloy® meters, all sizes. (63 barg PED / CRN option)
- ② De-rating for SS, Hastelloy® and Tantalum measuring tubes and outer cylinder de-rating for Tantalum meters (all sizes). De-rating for ASME 300 lbs flanges
- ③ De-rating for ASME 150 lbs flanges

Flanges

- DIN flange ratings are based on EN 1092-1 2001 table 18, 1% proof stress material group 14EO
- ASME flange ratings are based on ASME B16.5 2003 table 2 material group 2.2
- JIS flange ratings are based on JIS B 2220: 2012 table 11 division 1 material group 022a

Pressure / temperature de-rating (metric) for Titanium meters with hygienic connections.

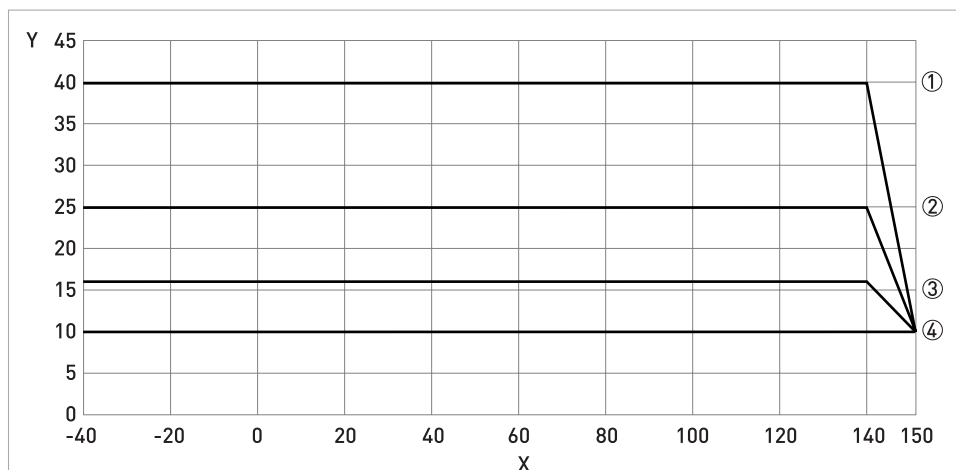

X temperature [°C]

Y pressure [barg]

- ① Welded connections DN06...40
- ② Welded connections DN50
- ③ Welded connections DN80
- ④ Adapter connections DN06...80

Pressure / temperature de-rating (Imperial) for Titanium meters with hygienic connections.

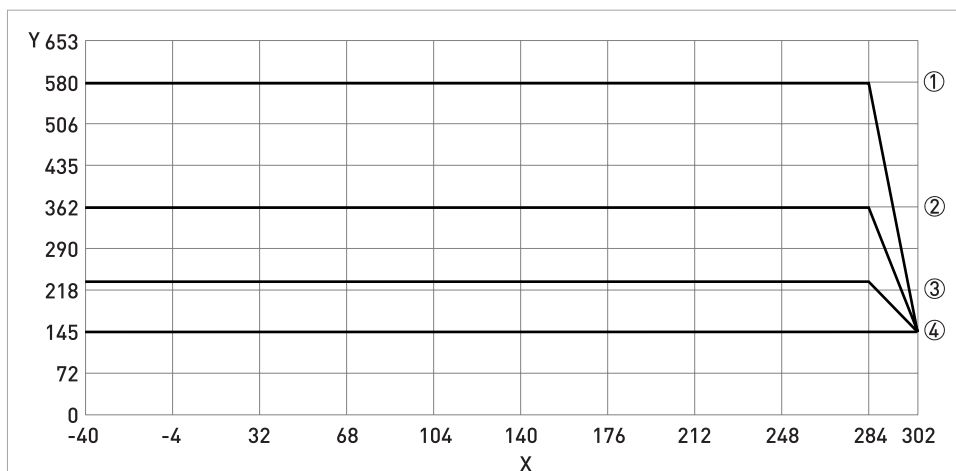

X temperature [°F]

Y pressure [PSI]

- ① Welded connections DN06...40
- ② Welded connections DN50
- ③ Welded connections DN80
- ④ Adapter connections DN06...80

Pressure / temperature de-rating (metric) for Stainless Steel meters with hygienic connections.

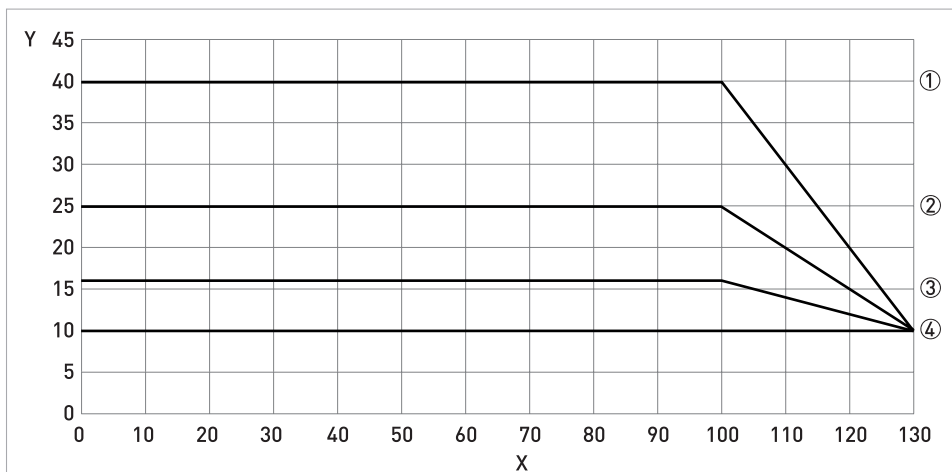

X temperature [°C]

Y pressure [barg]

- ① Welded connections DN06...40
- ② Welded connections DN50
- ③ Welded connections DN80
- ④ Adapter connections DN06...80

Pressure / temperature de-rating (imperial) for Stainless Steel meters with hygienic connections.

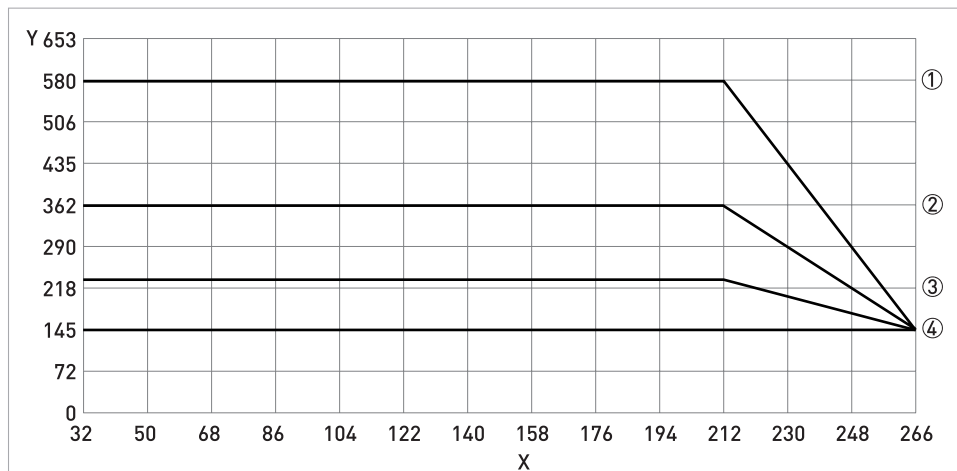

X temperature [°F]

Y pressure [PSI]

- ① Welded connections DN06...40
- ② Welded connections DN50
- ③ Welded connections DN80
- ④ Adapter connections DN06...80

Notes

- The maximum operating pressure will be either the flange rating or the measuring tube rating, **WHICHEVER IS THE LOWER!**
- The manufacturer recommends that the seals are replaced at regular intervals. This will maintain the hygienic integrity of the connection.

2.5 Dimensions and weights

2.5.1 Flanged versions

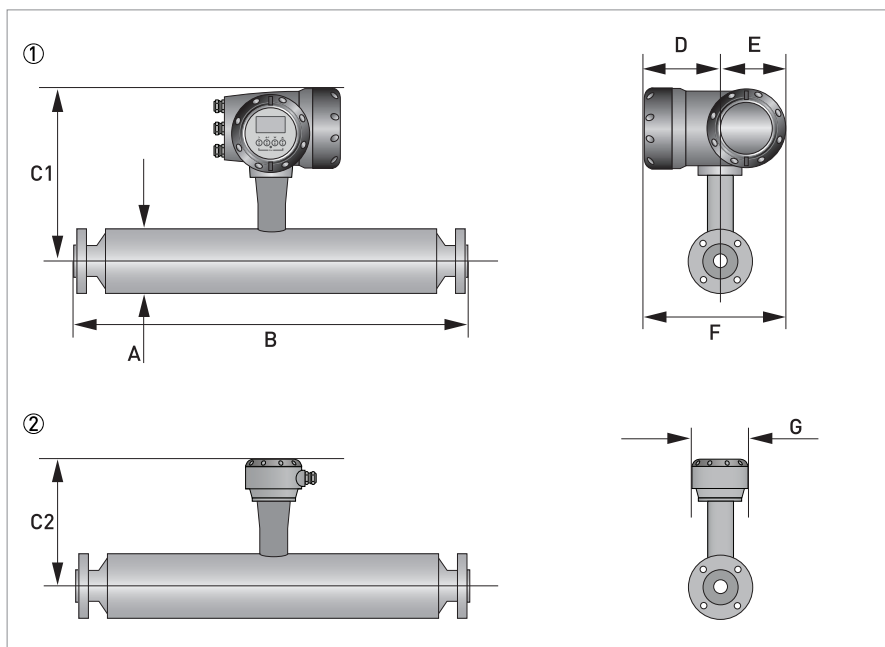

- ① Compact version
- ② Remote version

Meter weights for Titanium (T), Stainless Steel (S), Hastelloy®(H) and Tantalum (A)

	Weight [kg]						
	T/S 06	T/S/H/A 10	T/S/H/A 15	T/S/H/A 25	T/S/H/A 40	T/S/H/A 50	T/H 80
Aluminium (compact)	18.5	23	26	37	83	147	265
Stainless Steel (compact)	25.2	29.7	32.7	43.7	89.7	153.7	271.7
Aluminium (remote)	15.7	20.2	23.2	34.2	80.2	144.2	262.2
Stainless Steel (remote)	16.5	21	24	35	81	145	263
Tantalum add	-	1.8	2.7	4.5	9.2	15.1	-

	Weight [lbs]						
	T/S 06	T/S/H/A 10	T/S/H/A 15	T/S/H/A 25	T/S/H/A 40	T/S/H/A 50	T/H 80
Aluminium (compact)	40.7	50.6	57.2	81.4	182.6	323.4	583
Stainless Steel (compact)	55.4	65.3	71.9	96.1	197.3	338.1	597.7
Aluminium (remote)	34.5	44.4	51	75.2	176.4	317.2	576.8
Stainless Steel (remote)	36.3	46.2	52.8	77	178.2	319	578.6
Tantalum add	-	4	5.9	9.9	20.2	33.2	-

Measuring tube in Titanium (T), Stainless Steel (S) or Hastelloy® (H)

	Dimensions [mm]						
	T/S 06	T/S/H 10	T/S/H 15	T/S/H 25	T/S/H 40	T/S/H 50	T/S/H 80
A	102			115	170	220	274
B ①	420 ±2	510 ±2	548 ±2	700 ±2	925 ±2	1101 ±2	1460 ±4
B ②	428 ±2	518 ±2	556 ±2	708 ±2	933 ±2	1109 ±2	1468 ±4
C1 (compact)	311			318	345	370	397
C2 (remote)	231 ±2			237 ±2	265 ±2	290 ±2	317 ±4
D	137						
E	123.5						
F	260.5						
G	118						

① all pressure ratings up to 600 lbs and all DIN flanges with standard raised faces.

② ASME flange 600 lbs and all DIN flanges with raised face types: C; D; E and F.

	Dimensions [inches]						
	T/S 06	T/S/H 10	T/S/H 15	T/S/H 25	T/S/H 40	T/S/H 50	T/S/H 80
A	4			4.5	6.7	8.7	10.8
B ①	16.5± 0.08	20 ±0.08	21.6 ±0.08	27.5 ±0.08	36.4 ±0.08	43.3 ±0.08	57.5 ±0.16
B ②	16.8 ±0.08	20.4±0.08	21.9 ±0.08	27 ±0.08	36.7±0.08	43.3 ±0.08	57.8 ±0.16
C1 (compact)	12.2			12.5	13.6	14.6	15.6
C2 (remote)	9 ±0.08			9.3 ±0.08	10.4 ±0.08	11.4 ±0.08	12.5 ±0.16
D	5.4						
E	4.9						
F	10.2						
G	4.6						

① all pressure ratings up to 600 lbs and all DIN flanges with standard raised faces.

② ASME flange 600 lbs and all DIN flanges with raised face types: C; D; E and F.

Measuring tube in Tantalum (A)

	Dimensions [mm]				
	A 10	A 15	A 25	A 40	A 50
A	102	102	115	170	220
B (standard flange)	557 ±2	633 ±2	800 ±2	1075 ±2	1281 ±2
C1 (compact)	311	311	318	345	370
C2 (remote)	231 ±2	231 ±2	237 ±2	265 ±2	290 ±2
D	137				
E	123.5				
F	260.5				
G	118				

	Dimensions [inches]				
	A 10	A 15	A 25	A 40	A 50
A	4	4	4.5	6.7	8.7
B (standard flange)	21.9 ±0.08	24.9 ±0.08	31.5 ±0.08	42.3 ±0.08	50.4 ±0.08
C1 (compact)	12.2	12.2	12.5	13.6	14.6
C2 (remote)	9 ±0.08	9 ±0.08	9.3 ±0.08	10.4 ±0.08	11.4 ±0.08
D	5.4				
E	4.9				
F	10.2				
G	4.6				

2.5.2 Hygienic versions

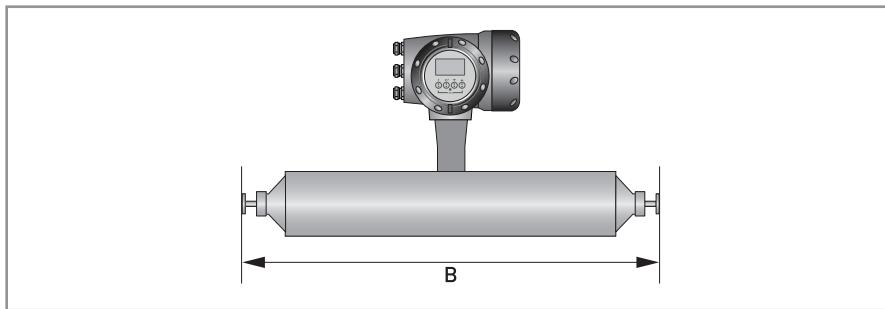

Hygienic connections: all welded versions

	Dimension B [mm]						
	T/S 06	T/S 10	T/S 15	T/S 25	T/S 40	T/S 50	T/S 80
Tri-clover							
1/2"	480 ±2	558 ±2	-	-	-	-	-
3/4"	-	-	596 ±2	-	-	-	-
1 1/2"	-	-	-	816 ±2	-	--	-
2"	-	-	-	-	1043	-	-
3"	-	-	-	-	-	1305 ±2	-
4"	-	-	-	-	-	-	1527 ±2
Tri-clamp DIN 32676							
DN10	484 ±2	564 ±2	-	-	-	-	-
DN15	-	-	602 ±2	-	-	-	-
DN25	-	-	-	761 ±2	-	-	-
DN40	-	-	-	-	986 ±2	-	-
DN50	-	-	-	-	-	1168 ±2	-
DN80	-	-	-	-	-	-	1584 ±2
Tri-clamp ISO 2852							
1 1/2"	-	-	-	816 ±2	-	-	-
2"	-	-	-	-	1043 ±2	-	-
3"	-	-	-	-	-	1305 ±2	-
4"	-	-	-	-	-	-	1527 ±2
DIN 11864-2 form A							
DN10	-	528 ±2	-	-	-	-	-
DN15	-	-	566 ±2	-	-	-	-
DN25	-	-	-	718 ±2	-	-	-
DN40	-	-	-	-	948 ±2	-	-
DN50	-	-	-	-	-	1124 ±2	-
DN80	-	-	-	-	-	-	1538 ±2

	Dimension B [inches]						
	T/S 06	T/S 10	T/S 15	T/S 25	T/S 40	T/S 50	T/S 80
Tri-clover							
1/2"	18.9 ±0.08	22 ±0.08	-	-	-	-	-
3/4"	-	-	23.5 ±0.08	-	-	-	-
1 1/2"	-	-	-	32.1 ±0.08	-	-	-
2"	-	-	-	-	41 ±0.08	-	-
3"	-	-	-	-	-	51.4 ±0.08	-
4"	-	-	-	-	-	-	49.5 ±0.08
Tri-clamp DIN 32676							
DN10	19 ±0.08	22.2 ±0.08	-	-	-	-	-
DN15	-	-	23.7 ±0.08	-	-	-	-
DN25	-	-	-	30 ±0.08	-	-	-
DN40	-	-	-	-	38.8 ±0.08	-	-
DN50	-	-	-	-	-	46 ±0.08	-
DN80	-	-	-	-	-	-	62.4 ±0.08
Tri-clamp ISO 2852							
1 1/2"	-	-	-	32.2 ±0.08	-	-	-
2"	-	-	-	-	41.1 ±0.08	-	-
3"	-	-	-	-	-	51.4 ±0.08	-
4"	-	-	-	-	-	-	60.1 ±0.08
DIN 11864-2 form A							
DN10	-	20.8 ±0.08	-	-	-	-	-
DN15	-	-	22.3 ±0.08	-	-	-	-
DN25	-	-	-	28.3 ±0.08	-	-	-
DN40	-	-	-	-	37.3 ±0.08	-	-
DN50	-	-	-	-	-	44.3 ±0.08	-
DN80	-	-	-	-	-	-	60.5 ±0.08

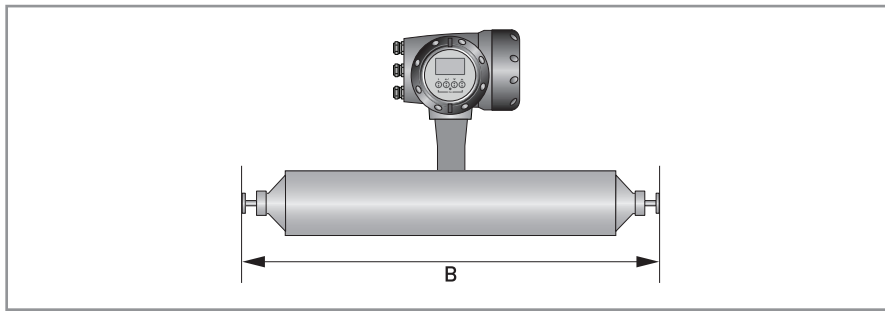

Hygienic connections: adapter versions (Tri-Clover & Tri-clamp)

	Dimension B [mm]				
	T/S 10	T/S 15	T/S 25	T/S 40	T/S 50
Tri-clover					
1/2"	597 ±2	-	-	-	-
3/4"	-	635 ±2	-	-	-
1"	-	665 ±2	-	-	-
1 1/2"	-	-	855 ±2	-	-
2"	-	-	-	1077 ±2	-
3"	-	-	-	-	1355 ±2
Tri-clamp DIN 32676					
DN10	590 ±2	-	-	-	-
DN15	-	628 ±2	-	-	-
DN25	-	-	787 ±2	-	-
DN40	-	-	-	1017 ±2	-
DN50	-	-	-	-	1193 ±2
Tri-clamp ISO 2852					
1"	-	665 ±2	-	-	-
1 1/2"	-	-	855 ±2	-	-
2"	-	-	-	1077 ±2	-
3"	-	-	-	-	1355 ±2

	Dimension B [inches]				
	T/S 10	T/S 15	T/S 25	T/S 40	T/S 50
Tri-clover					
1/2"	23.5 ±0.08	-	-	-	-
3/4"	-	25 ±0.08	-	-	-
1"	-	26.2 ±0.08	-	-	-
1 1/2"	-	-	33.7 ±0.08	-	-
2"	-	-	-	42.4 ±0.08	-
3"	-	-	-	-	53.3 ±0.08
Tri-clamp DIN 32676					
DN10	23.2 ±0.08	-	-	-	-
DN15	-	24.7 ±0.08	-	-	-
DN25	-	-	31 ±0.08	-	-
DN40	-	-	-	40 ±0.08	-
DN50	-	-	-	-	47 ±0.08
Tri-clamp ISO 2852					
1"	-	26.2 ±0.08	-	-	-
1 1/2"	-	-	33.7 ±0.08	-	-
2"	-	-	-	42.4 ±0.08	-
3"	-	-	-	-	53.3 ±0.08

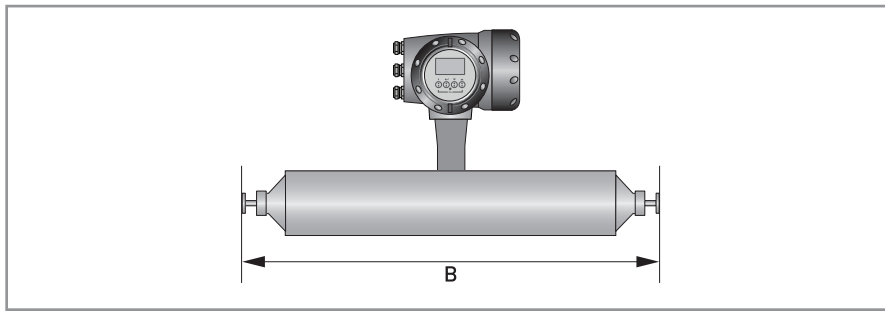

Hygienic connections: adapter versions (male thread)

	Dimension B [mm]					
	T/S 10	T/S 15	T/S 25	T/S 40	T/S 50	T/S 80
Male thread DIN 11851						
DN10	596 ±2	-	-	-	-	-
DN15	-	634 ±2	-	-	-	-
DN25	-	-	802 ±2	-	-	-
DN40	-	-	-	1040 ±2	-	-
DN50	-	-	-	-	1220 ±2	-
DN80	-	-	-	-	-	1658 ±2
Male thread SMS						
1"	-	665 ±2	-	-	-	-
1½"	-	-	852 ±2	-	-	-
2"	-	-	-	1074 ±2	-	-
3"	-	-	-	-	1360 ±2	-
Male thread IDF/ISS						
1"	-	664 ±2	-	-	-	-
1½"	-	-	854 ±2	-	-	-
2"	-	-	-	1076 ±2	-	-
3"	-	-	-	-	1354 ±2	-
Male thread RJT						
1"	-	676 ±2	-	-	-	-
1½"	-	-	866 ±2	-	-	-
2"	-	-	-	1088 ±2	-	-
3"	-	-	-	-	1366 ±2	-

	Dimension B [inches]					
	T/S 10	T/S 15	T/S 25	T/S 40	T/S 50	T/S 80
Male thread DIN 11851						
DN10	23.5 ±0.08	-	-	-	-	-
DN15	-	25 ±0.08	-	-	-	-
DN25	-	-	31.6 ±0.08	-	-	-
DN40	-	-	-	41 ±0.08	-	-
DN50	-	-	-	-	48 ±0.08	-
DN80	-	-	-	-	-	65.3 ±0.08
Male thread SMS						
1"	-	26.2 ±0.08	-	-	-	-
1½"	-	-	33.5 ±0.08	-	-	-
2"	-	-	-	42.3 ±0.08	-	-
3"	-	-	-	-	53.5 ±0.08	-
Male thread IDF/ISS						
1"	-	26.1 ±0.08	-	-	-	-
1½"	-	-	33.6 ±0.08	-	-	-
2"	-	-	-	42.4 ±0.08	-	-
3"	-	-	-	-	53.3 ±0.08	-
Male thread RJT						
1"	-	26.6 ±0.08	-	-	-	-
1½"	-	-	34.1 ±0.08	-	-	-
2"	-	-	-	42.8 ±0.08	-	-
3"	-	-	-	-	53.8 ±0.08	-

2.5.3 Heating jacket version

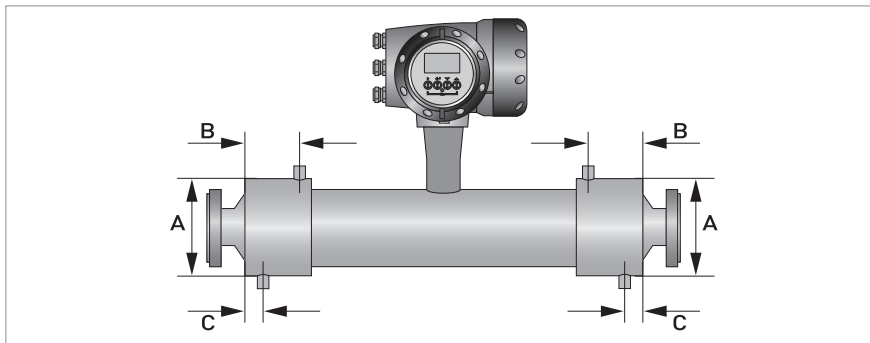

	Dimensions [mm]					
	10	15	25	40	50	80
Heating connection size	12 mm (ERMETO)			25 mm (ERMETO)		
A	115 ±1		142 ±1	206 ±1	254 ±1	305 ±1
Titanium						
B	36 ±1	51 ±1	100 ±1	90 ±1	175 ±1	385 ±1
C	20			26 ±1		
Stainless Steel & Hastelloy®						
B	-	51 ±1	55 ±1	90 ±1	100 ±2	200 ±2
C	-	20		26 ±1		
Tantalum						
B	-	51 ±1	55 ±1	90 ±1	100 ±1	-
C	-	20		26 ±1		-

	Dimensions [inches]					
	10	15	25	40	50	80
Heating connection size	½" (NPTF)			1" (NPTF)		
A	4.5 ±0.04		5.6 ±0.04	8.1 ±0.04	10 ±0.04	12 ±0.04
Titanium						
B	1.4 ±0.04	2 ±0.04	3.9 ±0.04	3.5 ±0.04	6.9 ±0.04	15.2 ±0.04
C	0.8			1.0 ±0.04		
Stainless Steel & Hastelloy®						
B	-	2 ±0.04	2.2 ±0.04	3.5 ±0.04	3.9 ±0.08	7.9 ±0.08
C	-	0.8		1.0 ±0.04		
Tantalum						
B	-	2 ±0.04	2.2 ±0.04	3.5 ±0.04	3.9 ±0.04	-
C	-	0.8		1.0 ±0.04		-

2.5.4 Purge port option

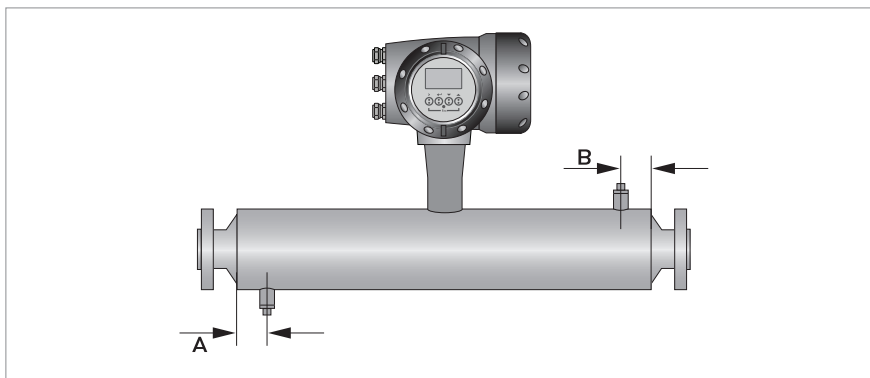

Dimensions [mm]							
	06	10	15	25	40	50	80
Titanium & Stainless Steel							
A	65	30			65		
B	30			65			
Hastelloy®							
A	-	30			65		
B	-	30			65		
Tantalum							
A	-	-	30	65		-	
B	-	-	30	65		-	

Dimensions [inches]							
	06	10	15	25	40	50	80
Titanium & Stainless Steel							
A	2.6	1.2			2.6		
B	1.2			2.6			
Hastelloy®							
A	-	1.2			2.6		
B	-	1.2			2.6		
Tantalum							
A	-	-	1.2	2.6		-	
B	-	-	1.2	2.6		-	

3.1 Intended use

This mass flowmeter is designed for the direct measurement of mass flow rate, product density and product temperature. Indirectly, it also enables the measurement of parameters like total mass, concentration of dissolved substances and the volume flow. For use in hazardous areas, special codes and regulations are also applicable and these are specified in a separate documentation.

Responsibility for the use of the measuring devices with regard to suitability, intended use and corrosion resistance of the used materials against the measured fluid lies solely with the operator.

This device is a Group 1, Class A device as specified within CISPR11:2009. It is intended for use in industrial environment. There may be potential difficulties in ensuring electromagnetic compatibility in other environments, due to conducted as well as radiated disturbances.

The manufacturer is not liable for any damage resulting from improper use or use for other than the intended purpose.

3.2 Mounting restrictions

3.2.1 General installation principles

There are no special installation requirements but you should note the following points:

- Support the weight of the meter.
- The meter can be supported on the sensor body.
- On larger meter sizes and hygienic connections, it is strongly recommended that the meter is not supported solely by the process pipework.
- No straight runs are required.
- The use of reducers and other fittings at flanges, including flexible hoses, is allowed but you should take care to avoid cavitation.
- Avoid extreme pipe size reductions.
- Meters are not affected by crosstalk and can be mounted in series or in parallel.
- Avoid mounting the meter at the highest point in the pipeline where air / gas can collect.

Mounting positions

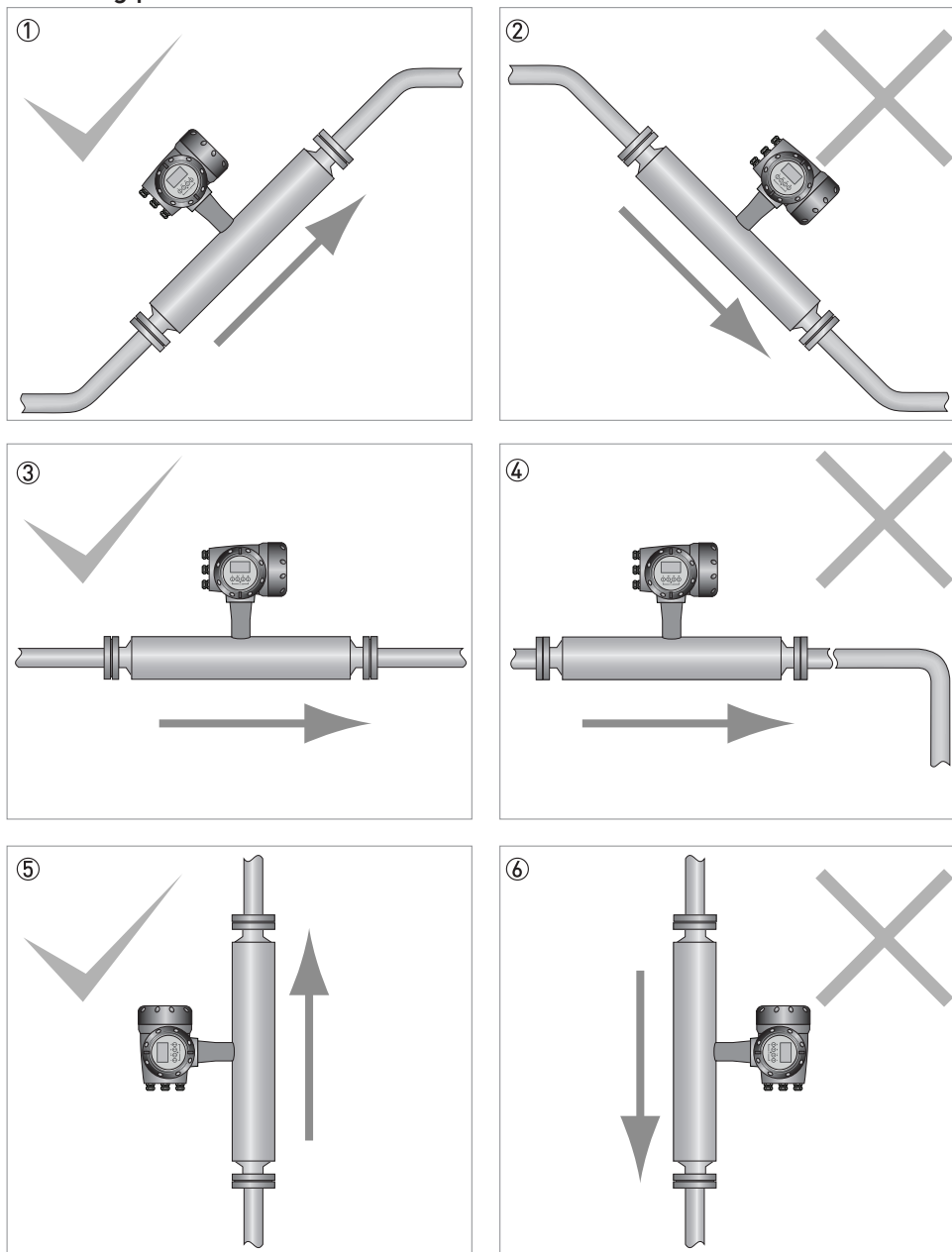

- ① The meter can be mounted at an angle but it is recommended that the flow is uphill.
- ② Avoid mounting the meter with the flow running downhill because it can cause siphoning. If the meter has to be mounted with the flow running downhill, install an orifice plate or control valve downstream of the meter to maintain backpressure.
- ③ Horizontal mounting with flow running left to right.
- ④ Avoid mounting meter with long vertical runs after the meter as it can cause cavitation. Where the installation includes a vertical run after the meter, install an orifice plate or control valve downstream to maintain backpressure.
- ⑤ The meter can be mounted vertically but it is recommended that the flow is uphill.
- ⑥ Avoid mounting the meter vertically with the flow running downhill. This can cause siphoning. If the meter has to be installed this way, install an orifice plate or control valve downstream to maintain backpressure.

Zero calibration

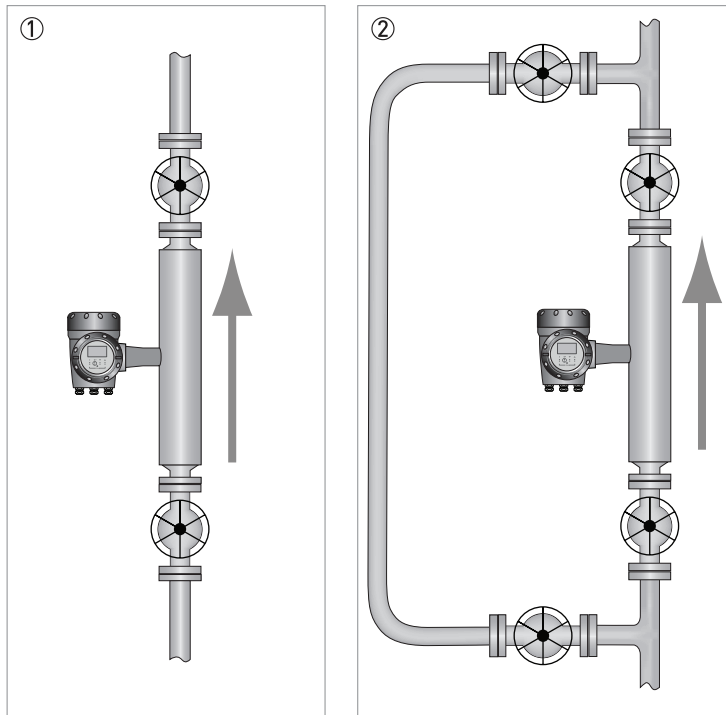

- ① Where the meter has been installed vertically, install shut-off valves either side of the meter to assist with zero calibration.
- ② If the process flow cannot be stopped, install a bypass section for zero calibration.

3.2.2 Sunshades

The meter **MUST** be protected from strong sunlight.

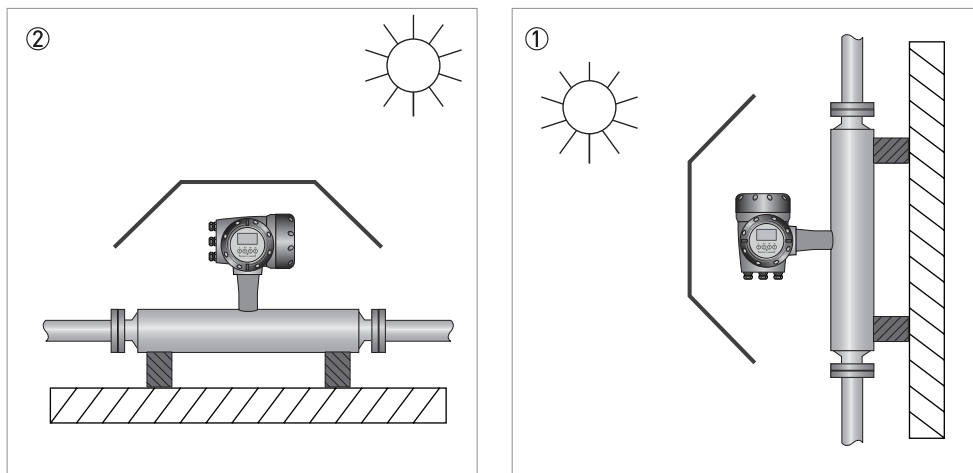

- ① Horizontal installation
- ② Vertical installation





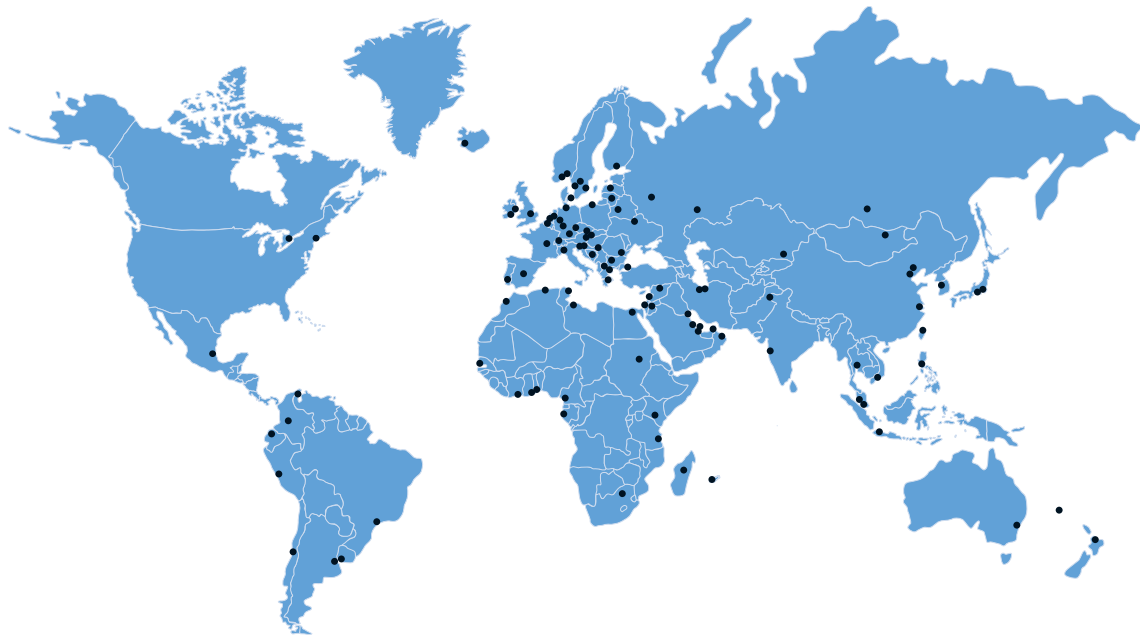

KROHNE – Process instrumentation and measurement solutions

- Flow
- Level
- Temperature
- Pressure
- Process Analysis
- Services

Head Office KROHNE Messtechnik GmbH
Ludwig-Krohne-Str. 5
47058 Duisburg (Germany)
Tel.: +49 203 301 0
Fax: +49 203 301 10389
info@krohne.com

The current list of all KROHNE contacts and addresses can be found at:
www.krohne.com

KROHNE